

REVISIONS				
ZONE	REV	DESCRIPTION	DATE	APPROVED
B1	A	UPDATED VENDOR NUMBER TO 82.7890.3A	11/1/2017	ZN

50991012

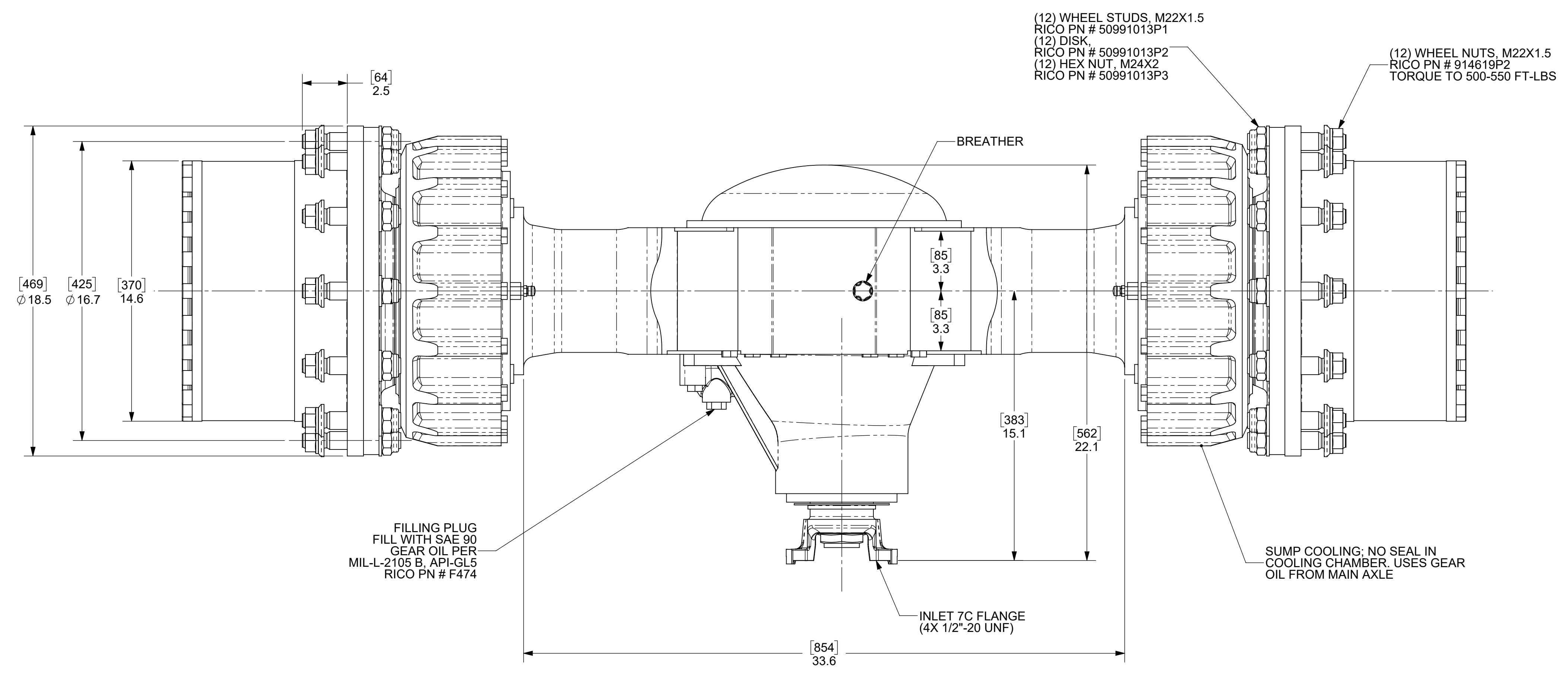
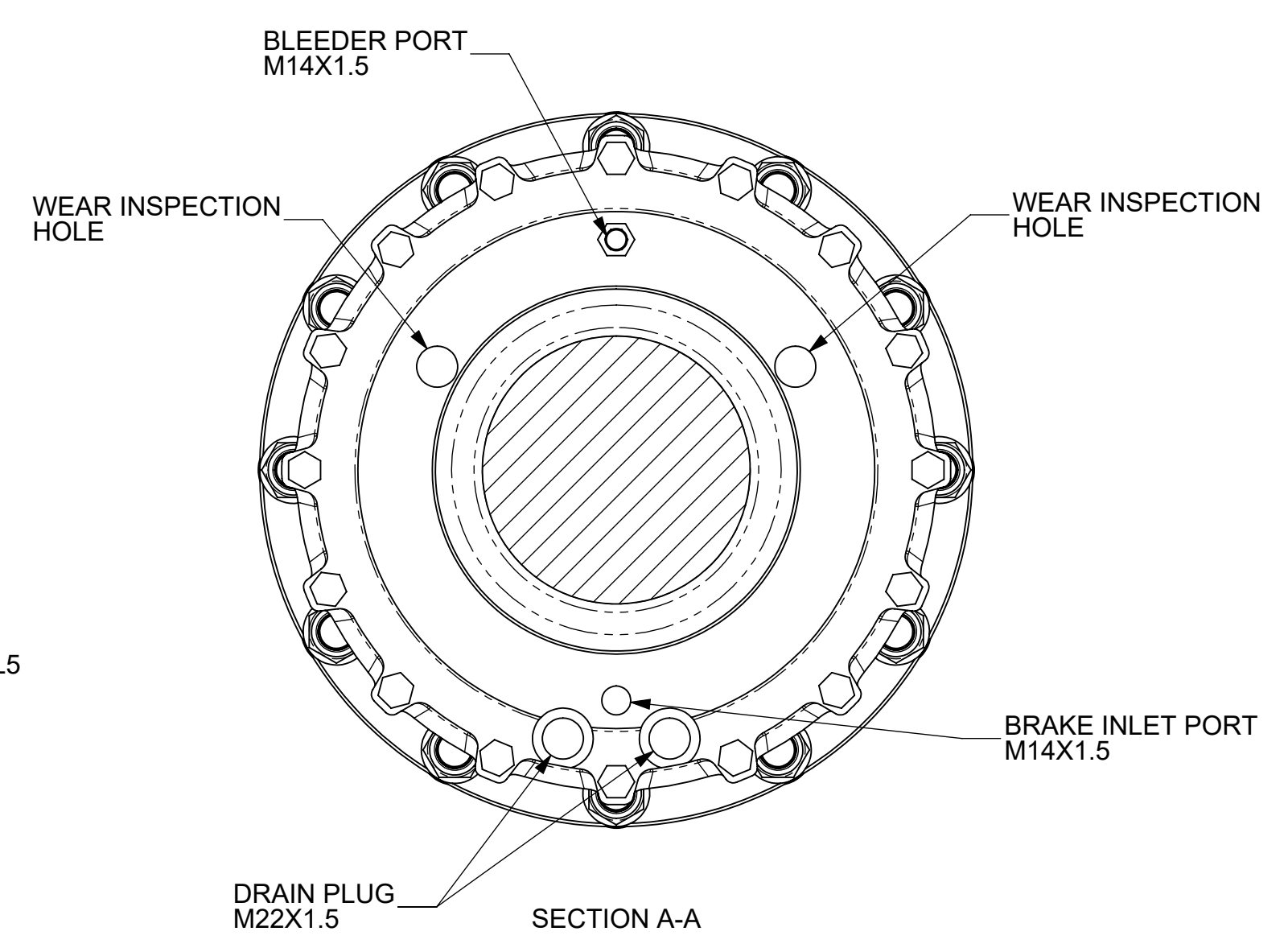
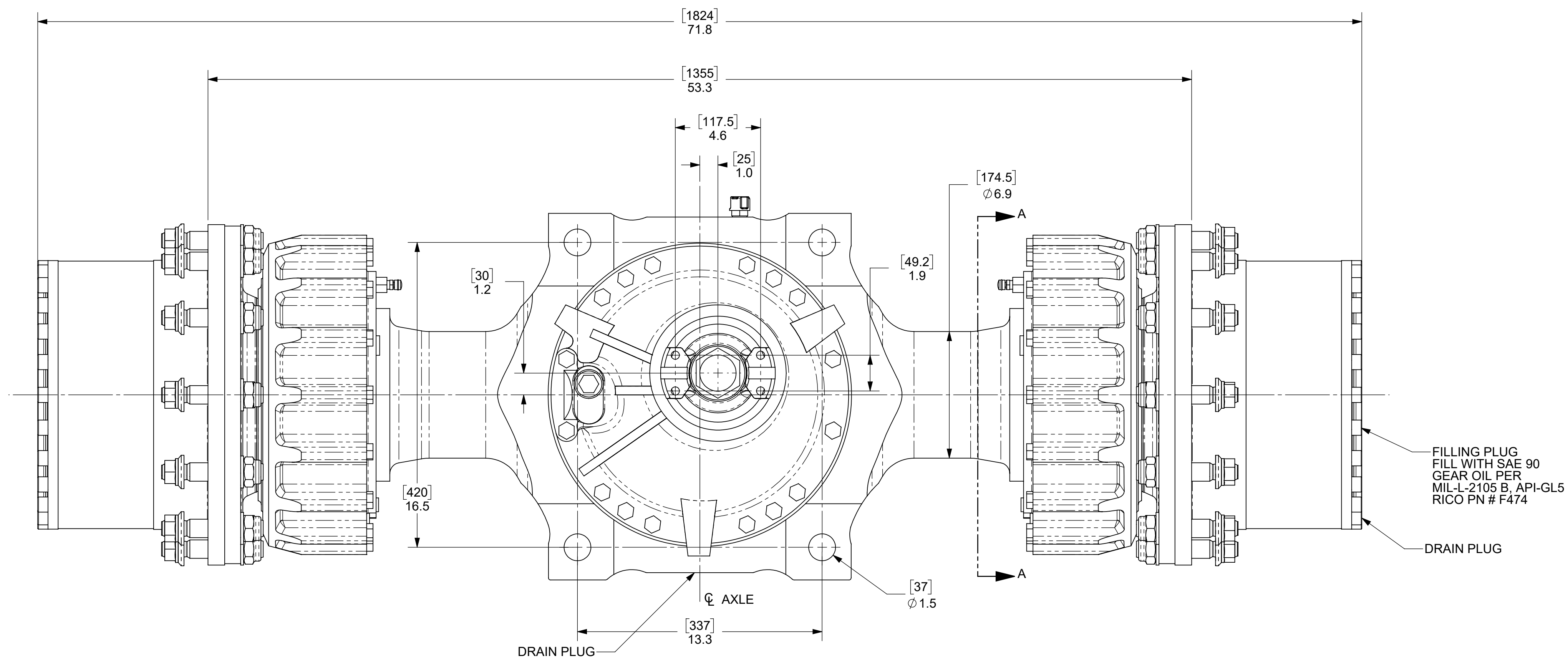

SPECIFICATIONS:
MANUFACTURER: KESSLER & CO.
MANUFACTURER PART NUMBER: 82.7890.3A Δ
DESCRIPTION: DRIVE AXLE D81PL489-NLB

MAX AXLE LOAD AT 9 MPH = 80,931 LBS (360,000 N)
MAX STATIC AXLE LOAD = 112,404 LBS (500,000 N)
MAX BRAKING TORQUE PER HUB END = 18,439 FT-LB (25,000 NM)

- THESE AXLES USE THE FOLLOWING KESSLER DATA SHEETS:
1. WN63201: DISC BRAKE NLB5340
 2. WN85601: NLB PERMISSIBLE OIL
 3. WN85602: NLB PERMISSIBLE OIL
 4. WN17005: USAGE OF AXLES WITH WET BRAKES
 5. WN85603: BRAKE NOISE PREVENTION

NOTE: THE SEAL(S) SEPERATING THE BRAKE CHAMBER FROM THE MAIN AXLE CHAMBER HAVE BEEN REMOVED. THEREFORE, THIS AXLE IS STRICTLY A "SUMP COOLING" AXLE ONLY, AND CAN NOT HAVE FORCE COOLING. THE COOLING PORTS ON THE AXLE CAN NOT BE USED.

UOS, DIM ARE IN INCHES. .X ±.1 .XX ±.04 .XXX ±.010 ANGULAR ±1°	THIS DOCUMENT CONTAINS PROPRIETARY INFORMATION AND NEITHER IT NOR THE INFORMATION CONTAINED THEREIN SHALL BE DISCLOSED OR DUPLICATED WITHOUT THE EXPRESS WRITTEN CONSENT OF BPR/RICO MFG, INC.		MFG PROCESS	RICO
	PURCH		TEMP FOR GENERAL MFG PROCESSES	
INTERPRET DIM AND TOL PER ASME Y14.5-2009.	DRAWN BY	ENGINEER	SIZE	TITLE
THIRD ANGLE PROJECTION	ZN	ANNA N. STELMASCZUK	D	DRIVE AXLE
	9/16/2020	9/16/2020	SCALE 1:4	DRAWING NUMBER
				50991012
				REV LEVEL
				A
				WEIGHT
				2997.6 LB
				SHEET 10F1

A

B

C

D

8

7

6

5

4

3

2

1