

Service-Manual
BPR-Rico USA
50991006

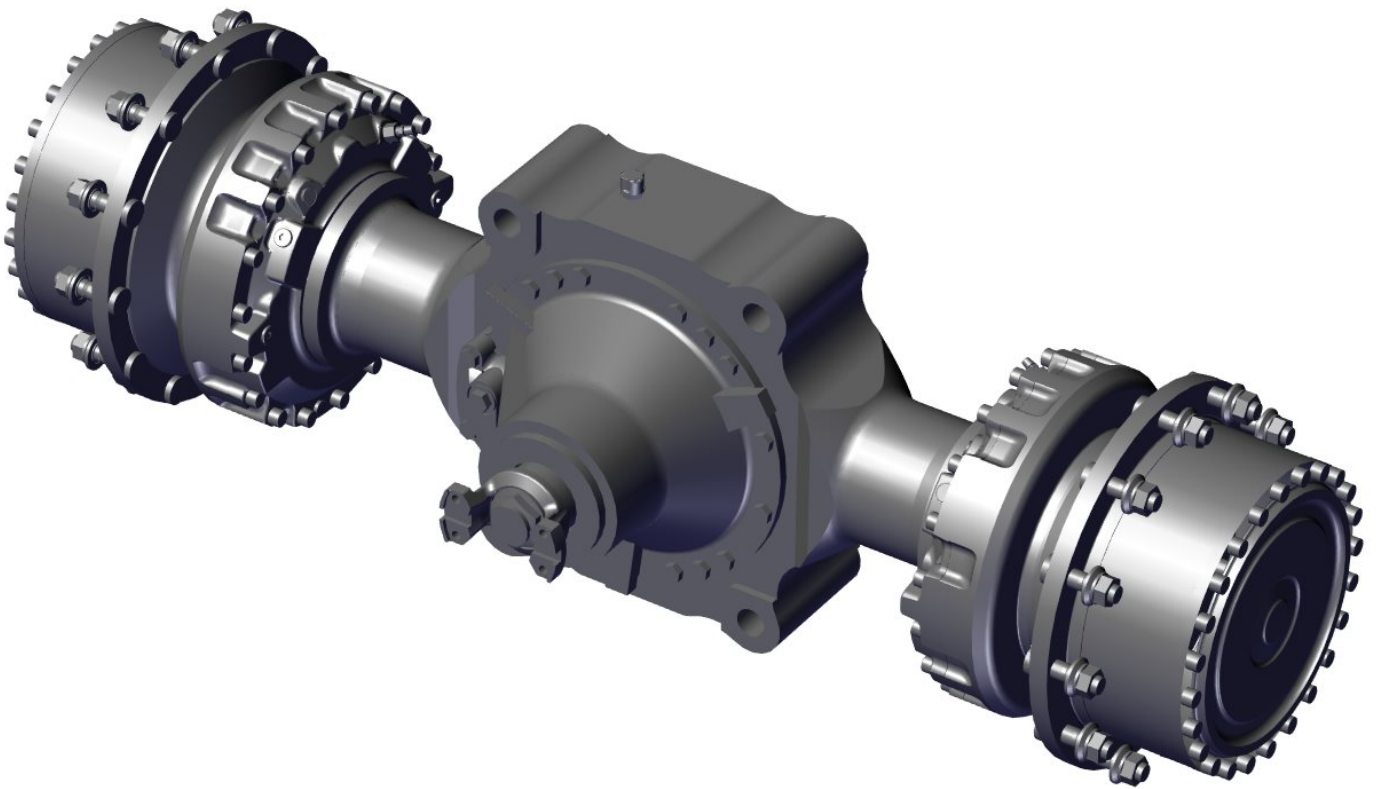

RICO

Contact RICO Equipment @
customerservice@ricoequipment.com or call us at
(330) 723-4050 option2

Edition 01/2016
Original

Introduction

Axles, transmissions, wheel gears and non drive wheels from (hereinafter referred to as RICO) are designed and manufactured in accordance with the state of the art and the recognised technical safety regulations.

This documentation describes the state of the art at the time the documentation was created. Although the documentation was created with great care RICO accepts no liability for any errors with respect to the depiction and description.

This documentation is not subject to revision service. We reserve the right to make modifications without prior notice.

Due to continuous developments and technical improvements of our products, the depictions in the following work steps may deviate or differ from the actual product / component. Drawings, graphics, pictures and photos are generally not true-to-scale.

This manual was developed for technicians who have been trained by RICO for the repair and servicing of RICO axles, transmissions, wheel gears and non drive wheels.

The manual must be stored where it is available to the technicians at all times.

The company will not be liable for damages and consequential costs resulting from improperly executed work by third parties. This also applies if spare parts other than those specified by RICO are used.

RICO offers customer service tools that make working on axles, transmissions, wheel gears and non drive wheels easier and safer.

General information

Axles, transmissions, wheel gears and non drive wheels from RICO may be used only in technically flawless condition and as specified, in a safety- and hazard-conscious manner and in compliance with the manual. Defects, especially those that could impair safety, must be remedied immediately. It is likewise prohibited to use defective or improperly serviced, repaired or modified axles, transmissions and non drive wheels.

In addition to and having priority over the warning and safety information in this manual, the applicable national safety and environmental regulations also apply.

Maintenance, repairs or modifications may be performed only by trained specialists. The manual must be read prior to starting maintenance, repairs or modifications. In case of ambiguities and uncertainty, always consult RICO.

When performing maintenance and repairs, comply with the safety regulations and the statutory requirements for preventing injuries and damage to the product. Persons who perform these tasks are obligated to become familiar with and comply with these regulations. These persons are responsible for the occupational safety.

After conducting maintenance and repairs, the product must be inspected to ensure that it is functioning properly. In case of major repairs and overhauls it is recommended to send the entire components (axle, gear, wheel gear and non drive wheel) to RICO.

All maintenance instructions in the RICO manual must be complied with.

Assembly and disassembly must be carried out in a clean work area.

Use special tools from RICO for the work.

Before reinstalling used parts, they must be inspected for damage, undamaged contact surfaces and wear. It is especially important to ensure that no chips or other foreign objects remain in the axles, transmissions, wheel gears and non drive wheels.

To remove the components (axle, gear, wheel gear and non drive wheel) from the vehicle, read the instructions of the vehicle manufacturer. The following descriptions assume that the component has been removed and mounted on a mounting device for further processing.

Safety

Explanation of the warning information and symbols appearing in the Service Manual

DANGER



Highest danger level

There is immediate danger of death or severe injury in case of failure to comply with this safety notice.

- this arrow indicates the absolutely necessary measures for preventing the specific danger

WARNING



Second highest danger level

There is possible danger of death or severe injury in case of failure to comply with this safety notice.

- this arrow indicates the absolutely necessary measures for preventing the specific danger

CAUTION



Third highest danger level

There is danger of minor injury or property damage in case of failure to comply with this safety notice.

- this arrow indicates the absolutely necessary measures for preventing the specific danger

NOTICE



Failure to observe this will result in dangers to the machine and its functions.



Information

Offers additional information to facilitate working.

Special types of danger

⚠ DANGER



When working on brakes, make sure that releasing the braking force cannot result in unintentional movement of the machine.

⚠ DANGER



When working on assemblies with spring actuator elements, such as: brakes and brake cylinders, whether service brake or parking brake. The assemblies are under spring tension.

Improper opening can cause parts to suddenly be released and fly off.

- In such cases, always comply with the safety, repair and maintenance instructions of the suppliers.

⚠ DANGER



Special care is necessary when working on wet multiple disk brakes. They are under high spring tension.

Improper installation and/or removal of the brake can cause parts to suddenly be released and fly off.

- Do not pre-tension and release the tension on the springs by means of the brake housing screw connections!
- Open the screw connection of this brake only using a suitable press or mounting device
- Preferably, installation/removal should be carried out by RICO

⚠ DANGER



Never remain directly in front of the wheel rim during deflation or inflation.

The pressure inside the tyre could cause parts to suddenly be released and fly off.

⚠ DANGER



When removing and mounting wheels on vehicles with clamped rims there is a danger that the tyre pressure can cause damaged parts of the rim to become released explosively when removing the clamped rim, which can cause severe or fatal injuries to the mechanic.

- Completely deflate the tyre before performing any task
- Never remain directly in front of the wheel rim during deflation or inflation of tyres

⚠ DANGER



Comply with tightening torque for wheel nuts.

- Retighten wheel nuts after a short operating period!

Basic safety information

⚠ WARNING



Comply with the safety signs on the axle.

- They must be kept in legible condition at all times.

⚠ WARNING



Only tools and equipment of the highest quality may be used; tools and equipment must be undamaged and electrical equipment must be approved for use in the respective country.

- Never use improvised devices.
- Use only original tools from RICO.

⚠ WARNING



Due to the unforeseeable dead weight of the single parts (e.g. wheel hub) or complete axles, transmissions, wheel gears or non drive wheels it is possible that they can fall or tip over during assembly work.

- Always use suitable, undamaged and tested cranes and load attachment gear for the respective load.
- Never work or stand under suspended loads
- Secure parts with a lashing strap and/or support
- Wear safety shoes

⚠ WARNING



Movement / rotation of different parts can result in the danger of injury to limbs.

- Never reach between moving parts with your hands

⚠ WARNING



Welding repairs are permitted only in coordination with RICO!

⚠ WARNING



Work on an axle, a transmission, a wheel gear and a non drive wheel is allowed only if the temperature of the respective component permits.

- Make sure that the oil has cooled before draining it
- Make sure that rotating parts have cooled before starting to remove them
- Wear fireproof gloves

⚠ CAUTION



During all machining work on metal parts, during which there is a danger of splinters (abrasive cutting, deburring, cleaning with compressed air, etc.), flying metal parts can cause eye injuries.

- Wear protective goggles

⚠ CAUTION



It is prohibited to wear loose clothing and long open hair when working on axles, transmissions, wheel gears and non drive wheels! Oils and greases can cause allergic skin reactions.

- Wear suitable protective clothing

NOTICE



Always observe the technical data (brake connections, tightening torques of screws and wheel locking nuts, etc.). Compliance with these specifications is very important for the safety of other people.

- For information on connections: see installation drawing
- For information on tightening torques: see "Important Information"
- For information on the drive assembly: see "Drive assembly"
- For information on the hub assembly: see "Hub assembly"
- For information on the planetary gear drive: see "Planetary gear drive"
- For information on the brakes: see "Brakes"

Table of contents

- 1** Important remarks

- 2** Lubrication intervals and maintenance instructions

- 3** General instructions for correct assembly and disassembly
Service tools

- 4** Assembly drive assembly

- 5** Assembly hub assembly

- 6** Assembly planetary gear drive

- 7** Assembly service brake

- 8** Assembly parking brake

Important remarks

Checking of screw connections, safety devices and corrosion

For safety reasons, the vehicle operator must check and service all important screw connections and safety devices at regular intervals.

- Wheel nuts
- Nuts of axle mounting bolts
- Tightening screws on housing joints and steering components will break the Loctite bond, which means the screws have to be reinstalled!
Secure screw connections and joints in accordance with specifications; in case of doubt, contact RICO
- Corrosion and cracks on support components (e.g. the axle spindle) are not permissible for reasons of operational safety and leaks.
Supporting components with cracks must be replaced!
- Cracks on steering components are not permissible for reasons of operational safety.
Steering components with cracks must be replaced!

Check of brakes

- Inspect brake lining and brake drum / brake disc regularly as well as wear of brake system parts.
- Inspect the free movement of brake system rods.
- In case of signs of excessive heating, consult a brake specialist or the manufacturer.

Service instructions

- Assembly and disassembly may be carried out only by trained specialists.
- Repair welding is permissible only after consulting RICO.
- To remove the axle from the vehicle, read the instructions in the vehicle manufacture's manuals. The following descriptions assume that the axle has been removed and mounted on a jig for further processing.
- Always comply with the safety regulations for your country. There is no guarantee that they correspond to the instructions in this manual.

Instructions for ordering spare parts

Warranty

RICO provides a warranty only for the original delivered replacement parts. Please be aware that the use of other than original replacement parts can have a negative effect on the design properties of the axle, therefore making it unsafe.

RICO will not be liable for any damages resulting from the use of other than original replacement parts and accessories. Please be aware that special production and delivery specifications exist for proprietary or third-party parts and that our replacement parts comply with the most recent standards as prescribed by law.

Ordering

When ordering original RICO replacement parts, please provide the following information:

1. Part number (no. on the installation drawing) → see identification plate
2. Serial → see identification plate
3. Vehicle manufacturer
4. Name of the spare part
5. Spare part number (drawing or DIN no.)
6. Quantity
7. Mode of dispatch

Important remarks

General lubrication instructions

Fill levels

- Are checked at the level control plugs.

Oil change

1. Place the vehicle in a horizontal position.
2. Draining of the oil is to be accomplished only in warm condition. Clean all lubrication points before, opening them. Open the drain holes on the carrier assembly, on the wheel assemblies, and if present, on the interaxle differential and drop gear housing. On the hub assemblies, the drain plug should be turned downward.
3. Oil draining
4. Replacement of the oil draining plugs
5. Remove the oil filler plug as well as the oil level control plug on the carrier assembly, on the wheel assembly, and, if present, on the interaxle differential and drop gear housing. (See page 3 lubrication points).
6. Oil filling
7. Check the oil level at the oil level plug hole (Overflow control).
Wait a few minutes.
If the oil level falls,
add oil
until the level remains constant.
8. Clean the grease nipples before lubrication.

Preservation of RICO axles for an extended storage period

- Replace the breather with a screw plug with a sealant in order to avoid water intrusion and oil leakage.
- Fill axles completely up with oil, the same applies to wet disc brakes.
- Protect machined surfaces (for example: rim surface, steering cylinder, brake disc, ...) with additional anticorrosive.

Before putting the axle into operation

- Drain storage oil. Fill the axle with suitable oil (see service manual RICO) to the required oil level.
- Check sealing contact surfaces for corrosion. Check the seals immediately after start-up for leakage and renew them if leaking.
- Completely remove the anticorrosive machined surfaces (for example: rim surface, steering cylinder, brake disc, ...). The rim face must be cleaned from rust or grease in order to secure a correct friction tight with the rim and to prevent loosening of the rim.
- Check axle structure for corrosion, especially after several years of storage.

Lubrication points

The binding lubrication points have to be taken from the according installation drawing of the axle

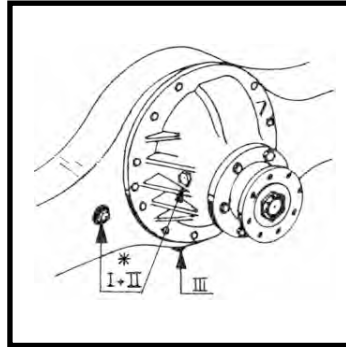

Single drive assembly

*The position is dependent from the respective axle version.

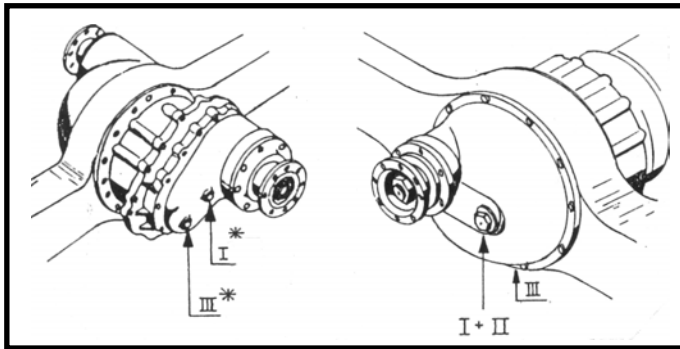

Drive assembly with throughdrive

*Version with interaxle differential.

Fill 1,5 liter oil at *I for first - time filling and for refilling!

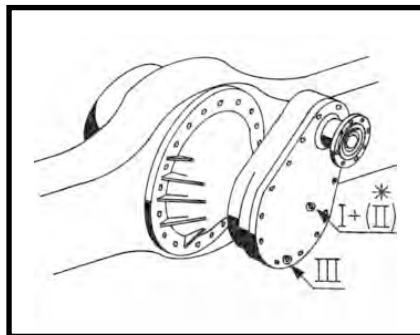

Drop gear D51 / D108

*II – only at version with separately oil space.

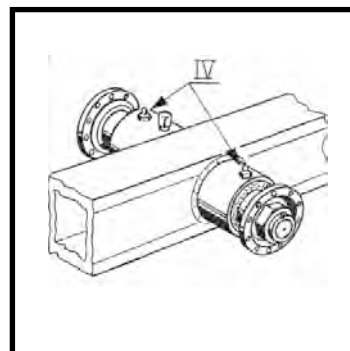

Cardan shaft intermediate bearing

I = Oil fill plug
II = Oil level control plug

III = Oil drain plug
IV = Grease nipple

Lubrication points

The binding lubrication points have to be taken from the according installation drawing of the axle

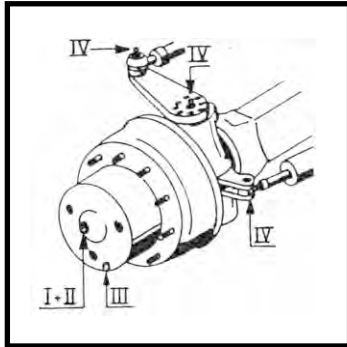

Hub assembly with planetary gear drive

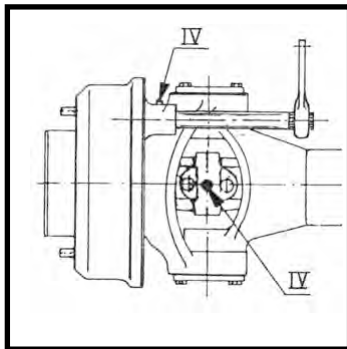

Lubrication points at universal joint and brake shaft.
(If not maintenance – free)

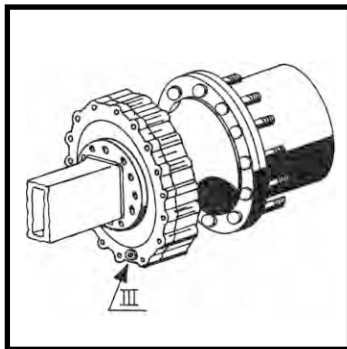

Hub assembly with wet disc brake

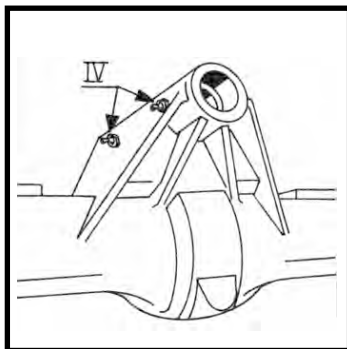

Tumbler bearing

I = Oil fill plug
II = Oil level control plug

III = Oil drain plug
IV = Grease nipple

Lubricants and lubrication intervals

| Lubrication point | Lubricant | Remarks | Lubrication intervals 1.) | | | | |
|---|---|---|--|--|-------------------------|----------------------|------------------------|
| | | | after 100Bh 1000Km | every 500Bh 5000Km | every 1000Bh 10000Km | at least 1x per year | at least 1x in 2 years |
| Drive assembly | Hypoid – gear oil per MIL-L – 2105 B / API GL 5 Hypoid – gear oil in multi – range characteristic per MIL-L – 2105 C / D / API GL 5 SAE 90 or multi grade oils for normal external temperature SAE 75 W – 90; SAE 75 W – 85 for external temperature lower – 10°C SAE 140 or multi grade oils for external temperature over + 30°C | Oilchange | ⊕ | | ⊕ | ⊕ | |
| Wheel hub planetary gear drive | | Check oil level at control points monthly | ⊕ | | ⊕ | ⊕ | |
| Interaxle differential | | ⊕ | | ⊕ | ⊕ | | |
| Drop gear/ Gear boxes | | ⊕ | | ⊕ | ⊕ | | |
| Wheel bearing oil lubricated | | ⊕ | | ⊕ | ⊕ | | |
| Multi disk parking brake | Hydraulic oil ISO VG 32 | Oilchange wet running | ⊕ | | ⊕ | ⊕ | |
| Cardan shaft intermediate bearing | Fuchs Renolit LX-NHU 2 | if provided for | | | ⊕ | ⊕ | |
| Steering knuckle bearing | Multi – use grease lithium saponified groove penetration per NLGI 2 f. e. Fuchs Renolit MP 150 | | ⊕ | ⊕ | | | |
| Steering knuckle bearing | | maintenance reduced | | | ⊕ | ⊕ | |
| Universal joint | | if provided for | ⊕ | ⊕ | | | |
| Track rod | | if provided for | ⊕ | ⊕ | | | |
| Steering cylinder -ball head/ -spherical plain bearing | | if provided for | ⊕ | ⊕ | | | |
| pinion bearing | | if grease lubricated | ⊕ | | ⊕ | ⊕ | |
| Brake shaft bearing | | Attention! 2.) | ⊕ | ⊕ | | | |
| Brake shoe bearing | | Attention! 2.) | Lightly greased at brake shoe new assembly | | | | |
| Wheel bearing | | if grease lubricated | Change grease at wheel hub disassembly | | | | ⊕ |
| Wet disc brake | | see chapter -7- | external cooled oilchange | dependent on tank volume / cooling system / operation conditions | | | |
| | not external cooled oilchange | | ⊕ | | ⊕ | ⊕ | |

(Bh = Hours of operation)

- 1.) Whichever occurs first.
- 2.) The bearing point is to be lightly lubricated only, to avoid the penetration of grease in the interior of the brake (use only hand operated grease gun and remove surplus grease!). Check regularly the brake shafts and if need correct the lubrication intervals (danger of overheating!)

Important – if a noise is produced on axles with self locking differentials

- On the axles with self locking differentials, a noise is produced if normal oils are used.
In case of abnormal noises and in case of a jerky roll off of the tyres, use gear oil EP with additives of the “Limited Slip” type conforming to **specification M 2C - 104 A**.

Recommendable hypoid gear oils corresponding MIL-L 2105 B/API GL 5 resp. MIL-L 2105 C/D/API GL 5

ARAL - Gearoil Hyp 90

AVIA - Gearoil Hypoid 90 EP

BP - Multiuse - Gearoil EP SAE 90

ELF - Tranself Typ B 90 / Tranself Typ B 80 W - 90

ESSO - Gearoil GX - D 90

FINA - Pontonic MP SAE 85 W - 90

FUCHS - Renogear Hypoid 90

MOBIL - HD 90 - A

SHELL - Spirax MB 90 / HD 90

TEXACO - Multigear EP SAE 85 W / 90

AGIP - Rotra MP / Rotra MP DB

On no account use “normal” gear oils!

General maintenance instructions

| Check - and maintenance points | Remarks | Maintenance intervals 1.) | | | | |
|--|--|---------------------------|--------------------------|--------------------------|----------------------------|----------------------------|
| | | after 50Bh 500Km | after 100Bh 1000Km | every 500Bh 5000Km | every 1000Bh 10000Km | at least 1x per year |
| Wheel bearing | Inspect, if necessary readjust wheel bearing | | ⊕ | | | ⊕ |
| Wheel nuts | Check and tighten with a torque wrench (after tire change after 50km and 200km) | ⊕ | ⊕ | ⊕ | | |
| Castle nuts/track rod Screws/drive flange Nuts/axle mounting bolts | Check and retighten (Verify the adjustment) | ⊕ | ⊕ | ⊕ | | ⊕ |
| Brakes (see also chapter 7) | Check lining wear, if necessary readjust, control the proper operation of the brake shafts | ⊕ | monthly | | | |
| Wet disc brake | Check lining wear | | | | | ⊕ |
| Wet disc brake - spring load design | Check lining wear | | | | ⊕ | |
| Steering - and trackrod lever | Check and retighten mounting bolts *) | | ⊕ | | | ⊕ |
| Bolted connections (for example drive assembly) | Check from time to time | | | ⊕ | | |
| Ring gear support bolt on drive assembly | Readjust (if necessary) | | | | | ⊕ |
| Seals | Check from time to time | monthly | | | | |
| Differential lock | Check function and the automatic return in original position | monthly | | | | |

(Bh = Hours of operation)

*) If the bolts are moving (Loctite brakes loose), the lever has to be mounted once more.

1.) Whichever occurs first.

- **General assembly /disassembly instructions**
 - **service tools**
-

General instructions for correct assembly and disassembly

General instructions for disassembly

- The disassembly occurs made inverted to the respective assembly instruction.
- Drain oil before removing, check for presence of metal particles.
- Mark the parts to each other before dismantle.
- Never use a hard object to separate tightly fitted assemblies. To remove bearings, drive flange and similar parts, use adequate pull-off tools.
- It is recommended that the special tools according 3.6 be used for disassembly.
- Before disassembly, the destruction of bearings and other components must check, if it is necessary to destroy it.
- Systematically replace used seals, O-rings and if needed bearings on disassembly.
- Replace or clean corroded parts.
- Do not place parts on dirty surface.

General instructions for assembly

- Clean parts before reassembly.
- The cages of bearings rotating in oil must coat with oil at reassembly.
- During mounting of radial seal rings, pay attention that there is sufficient overlap to the housing bores. Pay attention for a plain alignment of the radial seal ring. The seal lips may never be encountered Loctite!
- Oil seal rings and particularly the anti-dust lip seals must fill with grease.
- The universal joint shafts and the axle shafts must forcibly mounted (they must slide).
- Seal ring treads on flanges, shafts and so on, must preserve with Castrol Rustilo DWX 32 before mounting.
- Refill oil after assembly!

Application of Loctite and operating supplies

Application of Loctite and operating supplies

| | Type | colour | Application |
|------------|------------------|-------------|---|
| 1. LOCTITE | 243 | blue | Lightly locked screws |
| | 262 | red | Middle locked screws |
| | 270 | green | Highly locked screws |
| | 270 | green | Increased coefficient of friction in contact surfaces |
| | 510 | orange | Surface gasket |
| | 572 | white | Special gasket |
| | 638 | light-green | Gluing with big width of slit |
| | 5926 and 209 125 | blue | Surface gasket |
| 2. EPPLE | 33 | grey | Surface gasket |
| 3. DIRKO | | grey | Elastic gasket |

Remarks for working up Loctite and operating supplies

- Threads and surfaces have to be cleaned and free from colour, oil and grease before applying Loctite. Loctite will harden under following conditions:
 - Exclusion of air
 - Metal contact
 - Increased temperature
- Pre - assembly and control tightening must do in a short time (5 to 10 min.)
- The time between gluing and mounting of the parts should be shorter than 1h.
Exception: parts made from nonferrous metal have to be glued within one minute.
- Assembled parts must remain unloaded for at least 24 hours.
- Loctite quantity:

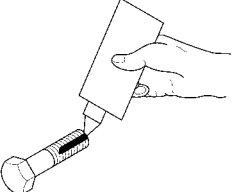
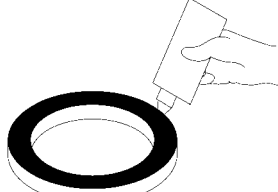
| | |
|--|---|
| <p>At screws:</p>  <p style="margin-left: 150px;">1 bead</p> | <p>At contact surfaces:</p>  <p style="margin-left: 100px;">Pay attention for a sufficient Loctite application!</p> |
|--|---|

Application of Loctite and operating supplies of hub assembly

| Safety blocked parts | Joint | Loctite | Operating supplies |
|---|----------------------|---------|--------------------|
| Spacer ring | Contact surface | 572 | - |
| Axle spindle | Screws | 262 | - |
| Axle spindle | Contact surface | 270 | - |
| Grommet | in planetary housing | 270 | - |
| Disc | in axle spindle | 270 | - |
| Adjusting screw with nut | in planetary housing | 270 | - |
| Support | Screw | 262 | - |
| Ring gear retainer | Screws | 270 | - |
| Pol wheel | Contact surface | 638 | - |
| Steering lever Track rod lever | Screws | 262 | - |
| Steering lever Track rod lever | Contact surface | 270 | - |
| Wheel hub cover | Thread | 572 | - |
| Radial seal rings Rubber casing | Contact surface | 572 | - |
| Radial seal rings Steel casing | Contact surface | 270 | - |
| Wheel safety nut → see chapter 5 → Adjustment of wheel bearings | | | |

Application of Loctite and operating supplies of differential and carrier assembly

| Safety blocked parts | Joint | Loctite | Operating supplies |
|---------------------------------|-----------------|---------|---|
| Drive flange | Nut surface | - | Epple 33 alternative Dirko grey |
| Diff-housing | Screws | 262 | - |
| Shifter cylinder (Diff-lock) | Contact surface | 572 | - |
| Diff.carrier (Through drive) | Contact surface | 510 | - |
| Drop gear housing | Contact surface | 510 | - |
| Diff.carrier | Contact surface | - | Epple 33 alternative Loctite 5926 and 209125 |
| Through drive cover | Contact surface | 510 | - |
| Differential strap | Screws | 262 | - |
| Adjustment nut screw | Screw | 270 | - |
| Ring gear | Screws | 262 | - |
| Ring gear | Contact surface | 270 | - |
| Ring gear support | Cap | 270 | - |
| Ring gear support | Thread | - | Epple 33 alternative Dirko grey |

Tightening torques

General instructions for tightening torques (Nm)

$\mu = 0,14$

All tightening torques are rated in Nm.

Tolerance of the tightening torques is **$\pm 5\%$**

(assuming a manually operated torque spanner is used)

Tightening torque of metric coarse-pitch thread

| Thread | Screw | Nut | Screw | Nut | Screw | Nut |
|--------|------------|----------|-------------|-----------|-------------|-----------|
| | 8.8 | 8 | 10.9 | 10 | 12.9 | 12 |
| M 4 | 3,0 | | 4,4 | | 5,1 | |
| M 5 | 5,9 | | 8,7 | | 10 | |
| M 6 | 10 | | 15 | | 18 | |
| M 8 | 25 | | 36 | | 43 | |
| M 10 | 49 | | 72 | | 84 | |
| M 12 | 85 | | 125 | | 145 | |
| M 14 | 135 | | 200 | | 235 | |
| M 16 | 210 | | 310 | | 365 | |
| M 18 | 300 | | 430 | | 500 | |
| M 20 | 425 | | 610 | | 710 | |
| M 22 | 580 | | 830 | | 970 | |
| M 24 | 730 | | 1050 | | 1220 | |
| M 27 | 1100 | | 1550 | | 1800 | |
| M 30 | 1450 | | 2100 | | 2450 | |

Tightening torque of metric fine pitch thread

| Thread | Screw | Nut | Screw | Nut | Screw | Nut |
|-------------|------------|----------|-------------|-----------|-------------|-----------|
| | 8.8 | 8 | 10.9 | 10 | 12.9 | 12 |
| M 8 x 1 | 27 | | 39 | | 46 | |
| M 10 x 1 | 55 | | 81 | | 95 | |
| M 10 x 1,25 | 52 | | 76 | | 90 | |
| M 12 x 1,25 | 93 | | 135 | | 160 | |
| M 12 x 1,5 | 89 | | 130 | | 155 | |
| M 14 x 1,5 | 145 | | 215 | | 255 | |
| M 16 x 1,5 | 225 | | 330 | | 390 | |
| M 18 x 1,5 | 340 | | 485 | | 570 | |
| M 20 x 1,5 | 475 | | 680 | | 790 | |
| M 22 x 1,5 | 650 | | 920 | | 1050 | |

Tightening torque for galvanized bolts and nuts!

Regard reduced tightening torque for galvanized bolts and nuts!

Tightening torque for brake caliper dowel screws (greased !)

| | |
|------------|-----------|
| M 20 x 1,5 | 400 + 100 |
| M 27 x 2 | 900 + 100 |

Tightening torque of the nut for steering stop

| |
|-----|
| 300 |
|-----|

Approximate value for the tightening torque for screw plug

| Thread | Tightening torque (Approximate value) | Tightening torque (Screw plugs with O-Ring) |
|---------|--|--|
| M14x1,5 | ca. 45 | 45 |
| M16x1,5 | ca. 60 | - |
| M22x1,5 | ca. 100 | 100 |
| M24x1,5 | ca. 120 | - |
| M30x1,5 | ca. 160 | - |
| M42x1,5 | ca. 260 | - |
| M45x1,5 | ca. 280 | - |

Units

Comparison table for units

| | | |
|---------------------------------------|---|---|
| 25,40 mm | = | 1 in (inch) |
| 1 mm | = | 0,0394 in (inch) |
| 1 kg (kilogram) | = | 2,205 lb (pounds) |
| 9.81.Nm (1 kpm) | = | 7,233 lbf x ft (pound force foot) |
| 1,356 Nm (0,138 kpm) | = | 1 lbf x ft (pound force foot) |
| 1 bar (1,02kp/cm ²) | = | 14,5 psi (pound force per square inch lbf/in ²) |
| 0,070 bar (0,071 kp/cm ²) | = | 1 psi (lbf/in ²) |
| 1 Litre | = | 0,264 Gallon (Imp.) |
| 4,456 Litre | = | 1 Gallon (Imp.) |
| 1 Litre | = | 0,220 Gallon (US) |
| 3,785 Litre | = | 1 Gallon (US) |
| 1609,344 m | = | 1 Mile (land mile) |
| 0°C (Celsius) | = | +32°F (Fahrenheit) |
| 1°C (Celsius) | = | +33,8°F (Fahrenheit) |
| 0°C (Celsius) | = | 273,15 Kelvin |
| 1°C (Celsius) | = | 274,15 Kelvin |

Names of the legal units

| Term | Symbol | New | Old | Conversion | Comment |
|-----------------|--------|-------------------|-----|--|------------------------|
| Torque | T | Nm (Newton meter) | kpm | 1 kpm = 9,81 Nm | T (Nm) = F (N) x r (m) |
| Moment of force | M | Nm (Newton meter) | kpm | 1 kpm = 9,81 Nm | M (Nm) = F (N) x r (m) |
| Pressure | pü | bar | atü | 1,02 atü = 1,02 kp/cm ² = 1 bar = 750 torr | |

Tightening torque wheel nut with thrust collar

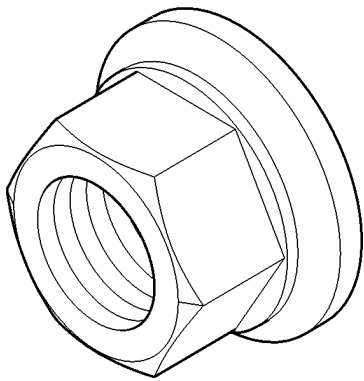

| Dimension | Tightening torque | |
|-----------|--|--|
| | Wheel nut with thrust collar – Phosphorous darkened - | Wheel nut with thrust collar – Galvanized - |
| M22x1,5 | 650 Nm | -- |

Tightening torques for castle nuts and adjusting nuts

Tightening torques for castle nuts on ball joints for track rods and ram cylinders

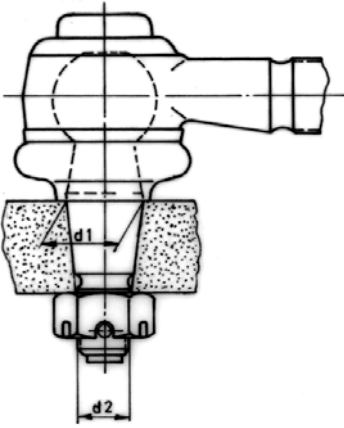
|  | Cone size | Thread | Torque |
|--|-----------|------------|-----------|
| | d1 (mm) | d2 (mm) | (Nm) |
| | 26 | M 20 x 1,5 | 200 - 220 |
| | 30 | M 24 x 1,5 | 280 - 300 |
| | 32 | M 27 x 1,5 | 290 - 320 |
| | 38 | M 30 x 1,5 | 340 - 360 |
| | 45 | M 39 x 1,5 | 410 - 430 |

The tightening torques of the different thread dimensions of the joints are applicable for nuts of quality S6.

Tightening torque of the adjusting nut resp. slotted nut at flanges resp. gearwheels ect.

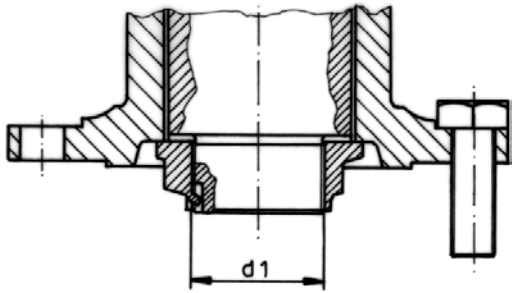
|  | Thread | Torque |
|---|------------|-------------|
| | d1 (mm) | (Nm) |
| | M 24 x 1,5 | 360 |
| | M 30 x 1,5 | 450 |
| | M 36 x 1,5 | 540 |
| | M 42 x 1,5 | 850 |
| | M 45 x 1,5 | 850 |
| | M 48 x 1,5 | 850 |
| | M 52 x 1,5 | 950 |
| | M 64 x 1,5 | 1050 - 1100 |

Tools

When ordering maintenance tools, please provide

- Part number (no. of installation drawing number)

and

- Serial number → see identification plate

(The illustrations are not binding for the design)

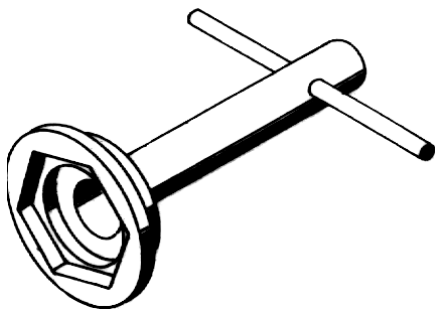

Spanner for wheel safety nut

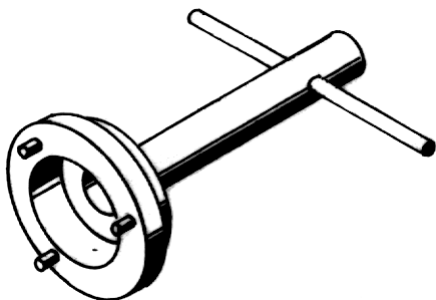

Spanner for wheel safety nut

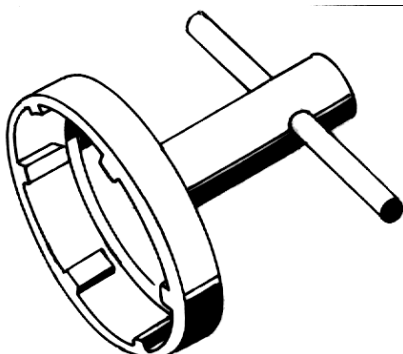

Spanner for splined nut (hub assembly)

Tools

When ordering maintenance tools, please provide

- Part number (no. of installation drawing number)

and

- Serial number → see identification plate

(The illustrations are not binding for the design)

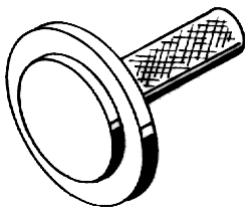

Seal ring sleeve driver

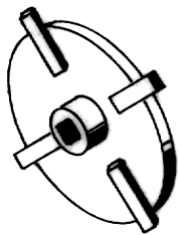

Spanner for thread rings
(Differential bearing)

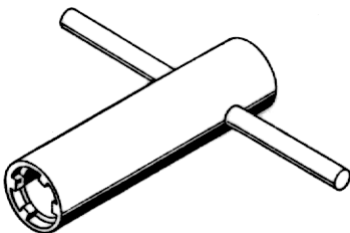

Spanner for counter nut
(Planetary gear drive)



Assembly cone for o – ring
(Differential lock)

Tools

When ordering maintenance tools, please provide

- Part number (no. of installation drawing number)

and

- Serial number → see identification plate

(The illustrations are not binding for the design)

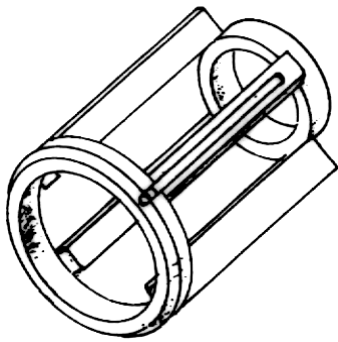

Centering tool for discs

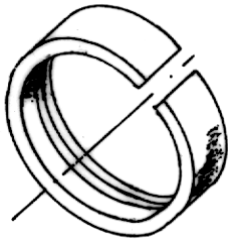

Installation tool for face seal

Adjustment of contact pattern of bevel gear teeth



NOTICE: search for the production numbers of the drive pinion and the ring gear.

It is only possible to achieve an optimal contact pattern, if:

| Version 1 | Version 2 |
|--|---|
| Production numbers <ul style="list-style-type: none">• on drive pinion (marked on the end face)• on ring gear (marked on the face of the ring gear) | <u>No</u> production numbers <ul style="list-style-type: none">• on drive pinion• on ring gear |
| ➤ The production numbers of the drive pinion and ring gear <u>must</u> match – only mount in pairs! | ➤ <u>indiscriminate</u> use of drive pinion and ring gear is possible – no pairing necessary! |

Checking the contact pattern of the gear teeth



1. Coat the teeth of the ring gear with spotting paste and then turn it several times until you can see pressure marks from the drive pinion on the coated teeth.
2. Check the contact pattern / pressure marks and compare them with the illustrations in the following table.
3. If necessary, make adjustments as shown in the table.

| | | |
|--|--|--|
| | <p>Optimal contact pattern</p> | |
| | <p>Contact pattern too high. Reduce drive pinion distance by correcting thickness of the adjustment disk. Adjust the backlash by moving the ring gear out.</p> | |
| | <p>Contact pattern too low. Increase drive pinion distance by correcting thickness of the adjustment disk. Adjust the backlash by moving the ring gear in.</p> | |

Securing of the striking nut



NOTICE: The brim of the striking nut has to be sheared only along the slot flank and the corner has to be bended on the slot ground.

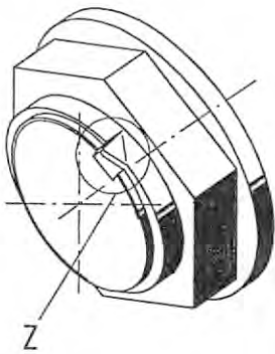

Figure 1

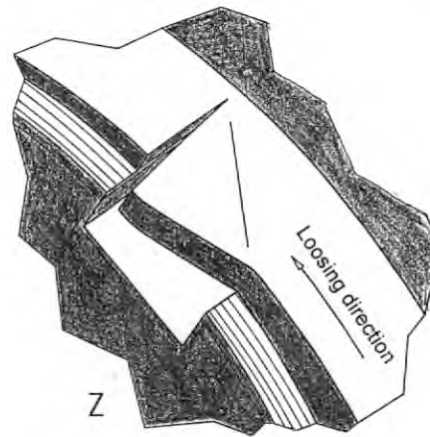

Figure 2

Use of Loctite and other operating supplies

- Striking nut at drive flange
 - **In thread: assembly paste with MoS2 (exception: through drive pinion see enumeration 2)**
 - **Front side contact surface: sealing compound (Epple 33 or equivalent)**

- Striking nut at through drive nut
 - **On thread: Loctite 262**

- Striking nut at gear wheels, bearings and so on
 - **On thread: assembly paste with MoS2**

Removing of the striking nut



NOTICE: Bend away the nose completely. Otherwise, the thread of the of the drive pinion will be damaged. Screw the nut off.



Figure 3

1. The secured striking nut.



Figure 4

2. Applying an applicable flat chisel in the slot between drive pinion and securing and removing the securing of the striking nut.



Figure 5

3. The loosened striking nut.

Differential and carrier assembly A 51

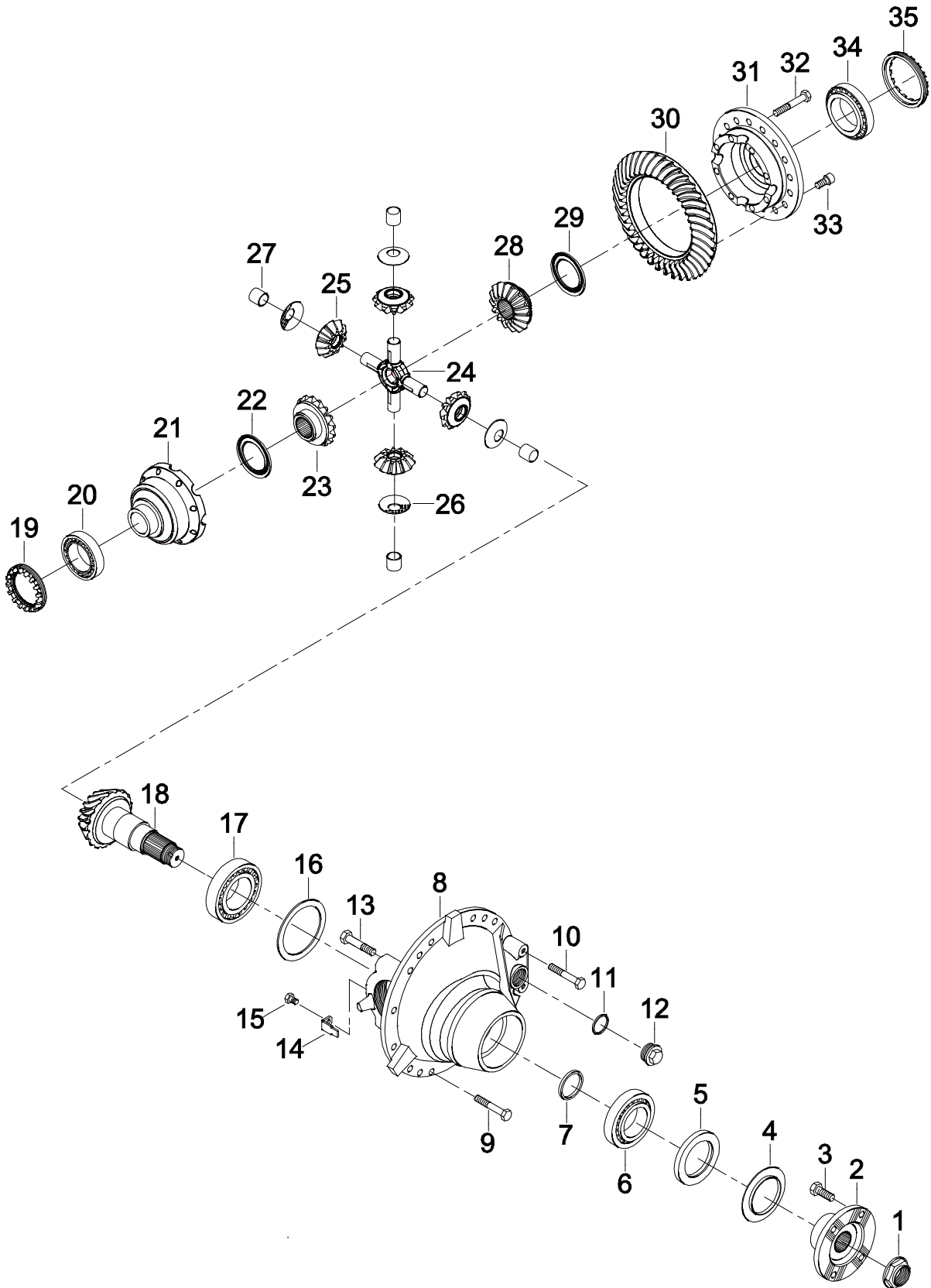

Overview of parts

1. Lock nut
2. Drive flange
3. Hexagon screw
4. Disk
5. Radial seal ring
6. Tapered roller bearing
7. Ring
8. Differential carrier
9. Hexagon screw
10. Hexagon screw
11. Sealing ring
12. Screw plug
13. Hexagon screw
14. Lock plate
15. Hexagon screw
16. Adjustment disk
17. Tapered roller bearing
18. Drive pinion
19. Setting ring
20. Tapered roller bearing
21. Differential housing
22. Disk
23. Differential side gear
24. Differential spider
25. Differential pinion
26. Disk
27. Bushing
28. Differential side gear
29. Disk
30. Ring gear
31. Differential housing
32. Hexagon screw
33. Hexagon socket screw
34. Tapered roller bearing
35. Setting ring

Adjustment of drive pinion distance

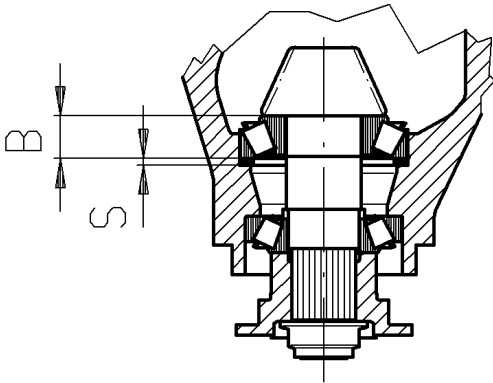

To obtain the proper tooth flank contact, adjust the axial position of the drive pinion with the thickness of the adjustment disc. The necessary thickness of the adjustment disc for first time assembly can be obtained by measurement (see calculation example).

| | |
|----------------|------|
| Drive assembly | A 51 |
| theoretical S | 3 |
| theoretical B | 38 |

The final thickness of the adjustment disc can be fixed during the checking of gear meshing at the assembled drive assembly (see page „Checking the contact pattern of the gear teeth” – 4.0.1).

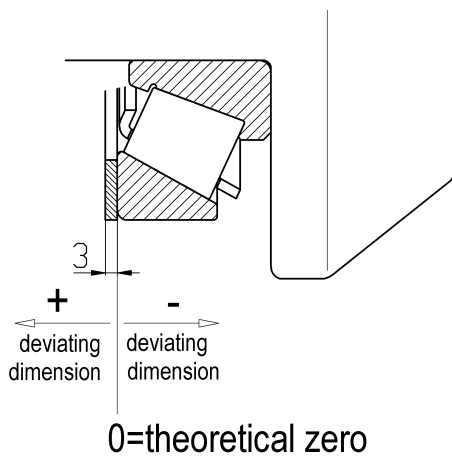



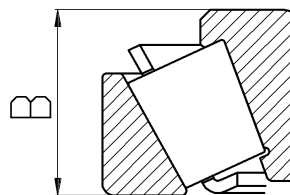

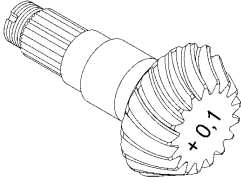
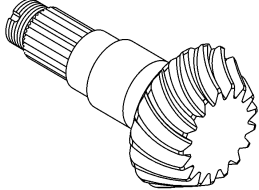

B = Measured width of the taper roller bearing.

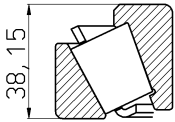
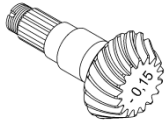

Assembly of differential and carrier assembly A51

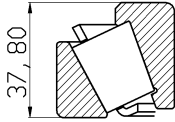
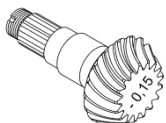
| Version 1 | Version 2 |
|--|---|
| <p>Adjustment dimension – A</p> <p>Deviating dimension (defined during production) is marked on the locating face of the pinion. It indicates the deviation from the specified dimension.</p> <p>Example: Deviation +0,1</p> | <p>Adjustment dimension – A</p> <p>Without inscription on the locating face of the pinion, the deviating from the specified dimension is 0.</p> <p>Example: Deviation 0</p> |
|  |  |

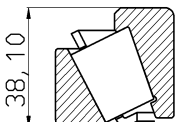
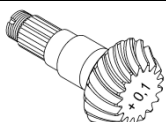
Sample calculations (dimensions in mm):

| Theor. adjustment disk thickness | Measured bearing width | Tolerance at drive pinion | Calculation of the required adjustment disk thickness | Required adjustment disk thickness |
|---|---|--|--|---|
|  |  | Version 1  | theor. disk thickness - deviation from bearing + deviation from pinion = required disk thickness |  |
| | deviation from the theoretical dimension +0,15 | deviation from the theoretical dimension -0,15 | $3,0 - 0,15 + 0,15 = 3,0$ | |
|  |  | Version 1  | theor. disk thickness + deviation from bearing + deviation from pinion = required disk thickness |  |
| | deviation from the theoretical dimension -0,20 | deviation from the theoretical dimension -0,15 | $3,0 + 0,20 + 0,15 = 3,35$ | |
|  |  | Version 1  | theor. disk thickness - deviation from bearing - deviation from pinion = required disk thickness |  |
| | deviation from the theoretical dimension +0,10 | deviation from the theoretical dimension +0,10 | $3,0 - 0,1 - 0,1 = 2,8$ | |

Fit corresponding disc and outer rings of the taper roller bearings.

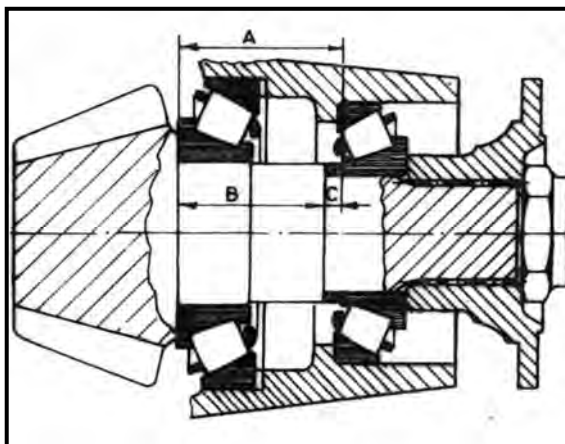
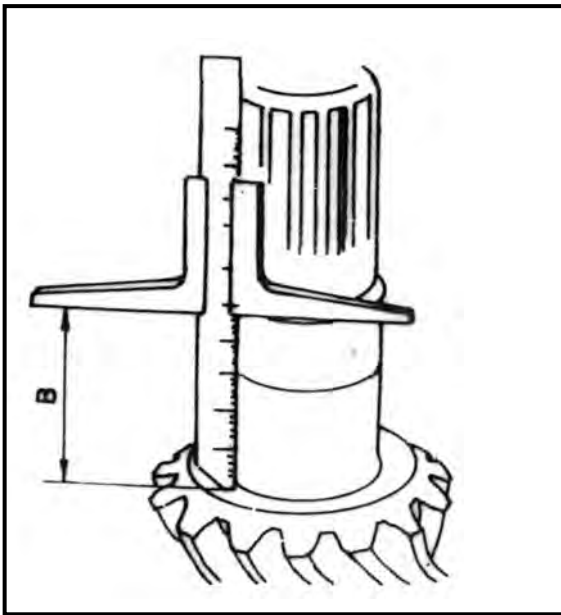

1. Insert the two outer rings of the taper roller bearings into the differential carrier.
2. Calculate the thickness C of the spacer ring.
 - a. Place the two inner rings of the taper roller bearings in their outer rings. Measure A.
 - b. Measure the dimension B of the drive pinion.
 - c. Thickness of the spacer ring $C = A - B$.
3. Heat the drive pinion side taper roller bearing to about 100°C and install it on the drive pinion shaft. (Drive on completely after it cools).
4. Install the spacer ring on the pinion shaft.
5. Install the drive pinion into the differential carrier. Heat the taper roller bearing inner ring at undersize to about 100°C and install it with a tube onto the drive pinion shaft.
6. Install the drive flange onto the drive pinion shaft. Tighten the safety nut according sheet 3.5. For tightening fix the differential carrier and block the drive flange.
7. Measure the resistance of the bearings by using a torque wrench. If the measured value is not the prescribed 0,8 to 1,2 Nm, adjust the resistance by modification of the thickness of the spacer ring. After arriving at the adjustment of the bearing, back - off the safety nut and draw off the drive flange.
8. Install the radial seal ring with Loctite 572 applied. Fill the radial seal ring with bearing grease. Fit the carrier of the parking brake (if present) on the differential carrier and tighten the screws. Slip on the drive flange together with the dimensionally stable assembled disk (if present), screw on the safety nut with sealing compound between the contact surfaces. Tighten the safety nut according sheet 3.5. Lock the nut by striking the nut brim into the slot of the pinion.

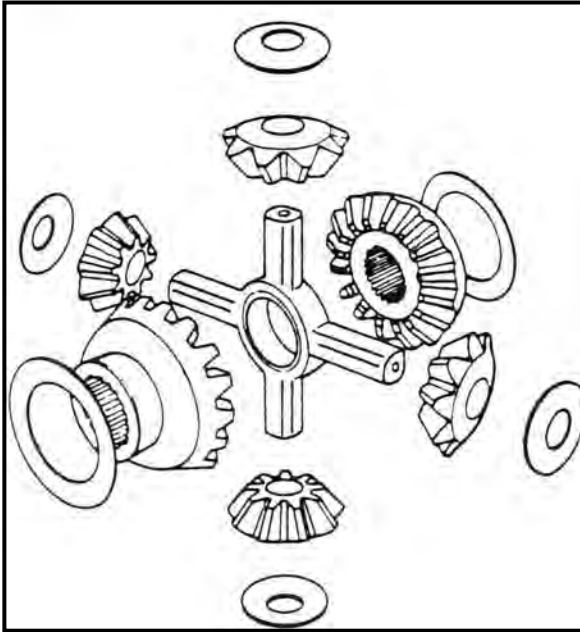

Before assembly all of the bevel gears and the thrust rings should be well oiled.

1. Place one differential side gear with the side gear thrust washer in the differential case.
2. Install the spider with differential gears and differential pinion thrust washers in the differential case.
3. Install the other differential side gear and side gear thrust washer. (At variants with Nospin differential install the Nospin diff. instead of the differential gears)
4. Install the other half of the differential case over the assembly and observe the alignment marks, tighten the differential case bolts. Secure with Loctite 262.
5. Check that all differential pinions can rotate easily.
6. Coat the contact surface of the ring gear with Loctite 270 and install the ring gear on the differential case by tapping lightly on the circumference. Tighten the ring gear bolts. Secure with Loctite 262.
7. Heat the two taper roller bearings to about 100°C and install them by using a sleeve.

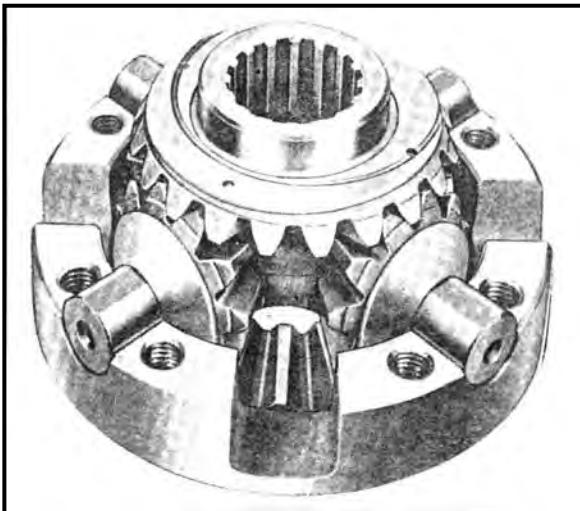

Dimension of backlash

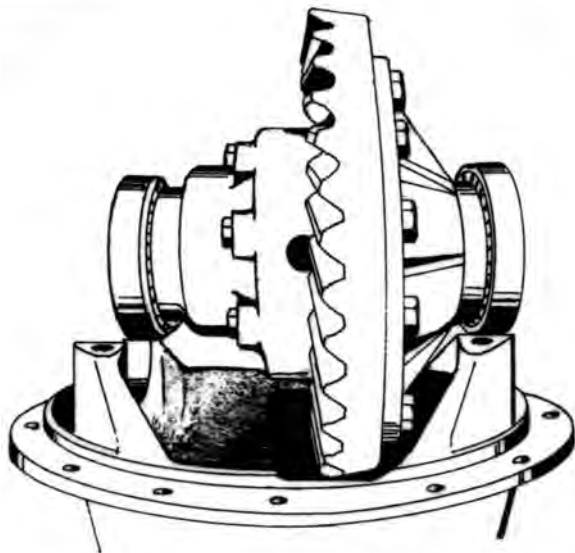

Place the differential with the outer rings of the taper roller bearings on the differential carrier which is in a vertical position, with mounted drive pinion.

Mount the differential straps and align them with the thread rings.

During this operation be careful of the alignment marks on the differential straps with respect to the differential carrier. (Do not interchange the differential straps.)

Backlash

Version 1

The smallest admissible value at the closest place is marked on the circumference of the ring gear.

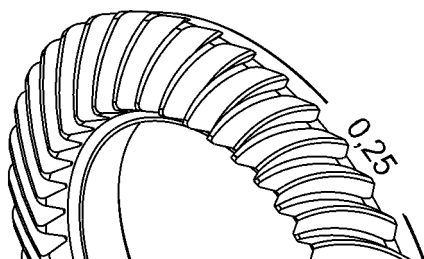

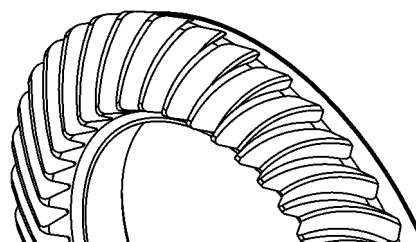

Version 2

Is no value marked on the circumference of the ring gear, the backlash is depend on the ring gear diameter (see following table).



| <i>Drive description</i> | <i>Ring gear diameter</i> | <i>Backlash</i> |
|--------------------------|---------------------------|-----------------|
| Drive assembly 51 | < 325 | 0,30 |

Adjustment of backlash

| Version 1 | Version 2 | |
|--|---|--|
|  |  | <p>Tighten the differential strap bolts by hand. By a counter rotation of the two thread rings, move the differential until the backlash is correct.</p> <p>Therefore hold the drive pinion at the drive flange. Check the backlash by careful forwards and rearwards rotating the ring gear. Use a dial indicator.</p> <p>Measure the backlash during a few times turns of the ring gear and if need correct the backlash, because of the smallest admissible value at the closest place must not be fall short of.</p> |
|  | | <p>Adjust the backlash according to sheet "Adjustment of contact pattern of bevel gear teeth".</p> <p>Tighten screws of the differential straps and lock them with Loctite 262.</p> <p>Adjust the bearing roll resistance trough tightening of the thread rings. Set value: 2,0 to 3,0 Nm. Check the value with a torque wrench. If measuring at the drive pinion / drive flange, take the ratio of the bevel wheel set into account.</p> <p>Screw the lock plates for the thread rings and secure with Loctite 270, if need bend the lock plates.</p> |

Hub assembly drive axle

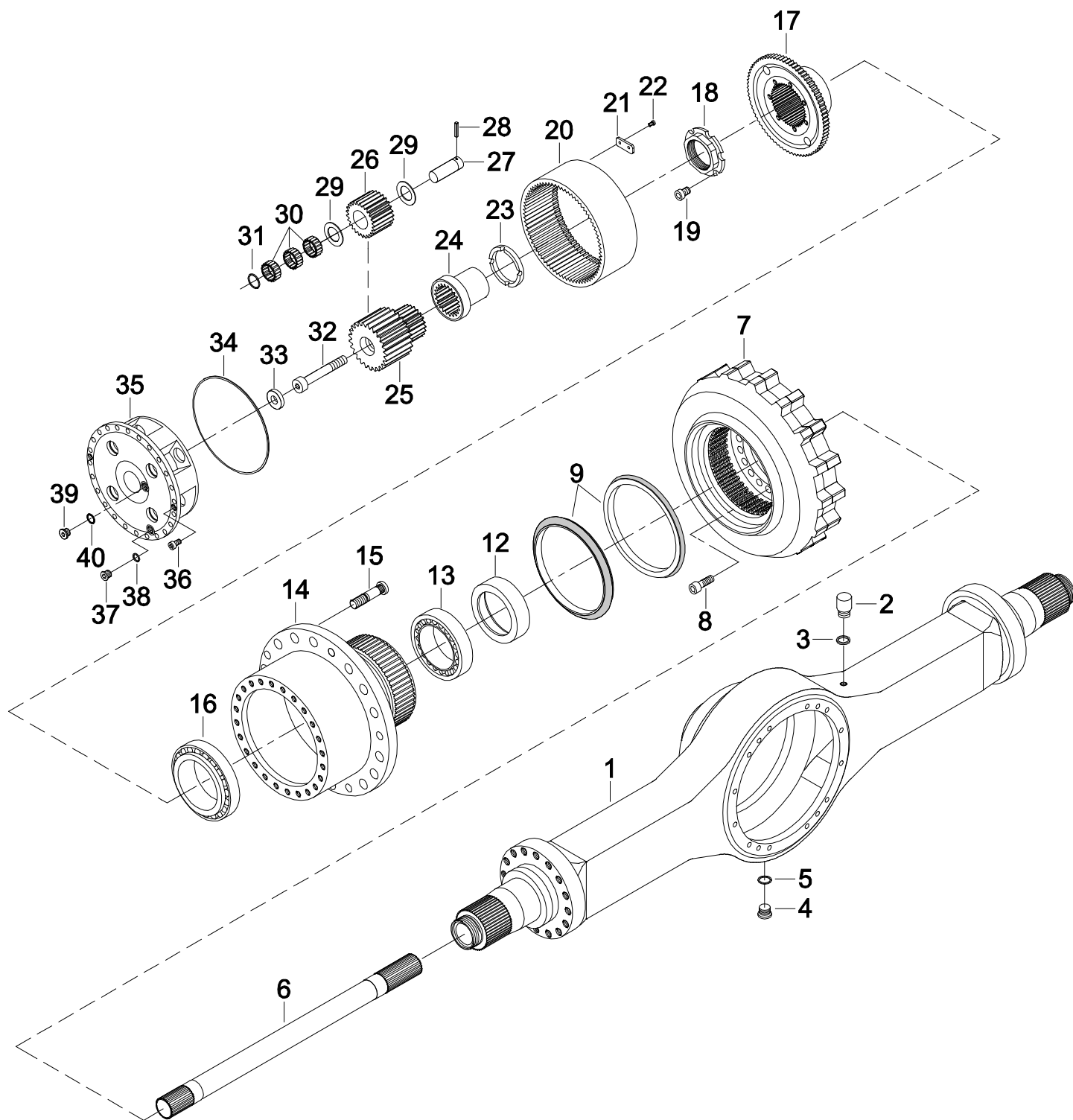

Overview of parts

| | | | |
|----|------------------------------|----|--------------------------|
| 1 | Axle housing | 21 | Securing plate |
| 2 | Breather | 22 | Hexagon screw |
| 3 | Sealing ring | 23 | Thrust washer |
| 4 | Screw plug | 24 | Bushing |
| 5 | Sealing ring | 25 | Sun gear |
| 6 | Axle shaft | 26 | Planetary gear |
| 7 | Wet multiple disk brake | 27 | Planetary bin |
| 8 | Hexagon socket screw | 28 | Spring-type straight pin |
| 9 | Face seal | 29 | Disk |
| 10 | - | 30 | Needle bearing |
| 11 | - | 31 | O-ring |
| 12 | Spacer ring | 32 | Hexagon socket screw |
| 13 | Tapered roller bearing | 33 | Thrust washer |
| 14 | Wheel hub | 34 | O-ring |
| 15 | Wheel stud | 35 | Planetary housing |
| 16 | Taper roller bearing | 36 | Hexagon socket screw |
| 17 | Ring gear carrier | 37 | Screw plug |
| 18 | Wheel bearing adjustment nut | 38 | Sealing ring |
| 19 | Hexagon socket screw | 39 | Screw plug |
| 20 | Ring gear | 40 | Sealing ring |

Assembly of the spacer ring

Coat the seat of the spacer ring on the steering knuckle resp. axle spindle with Loctite 572. Heat the spacer ring to about 100°C and push it by gently striking onto the steering knuckle resp. axle spindle. (The steering knuckle resp. axle spindle must be free of corrosion). Oil the seal ring tread onto the spacer ring.

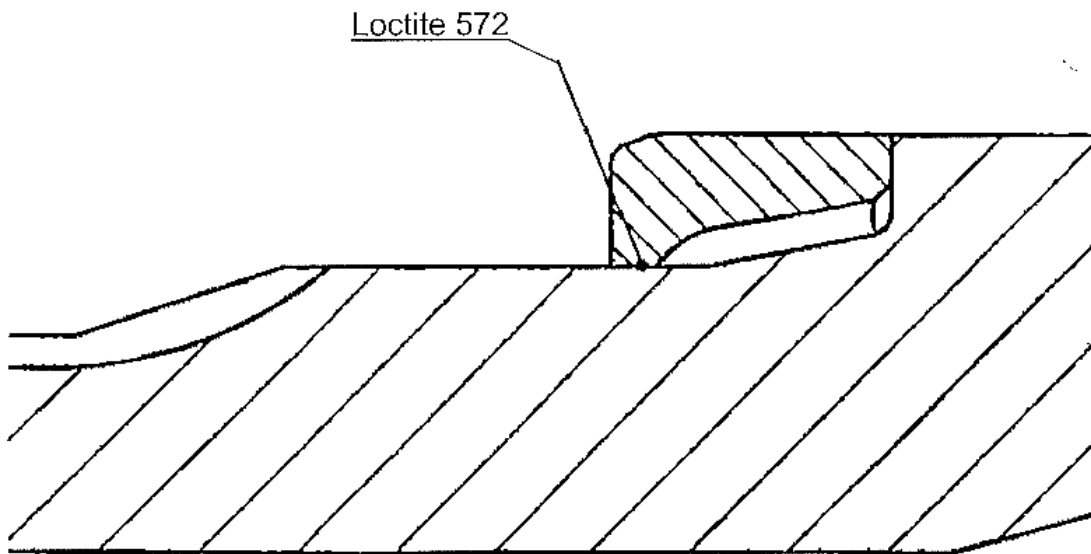

Assembly of the differential and carrier assembly onto the axle housing

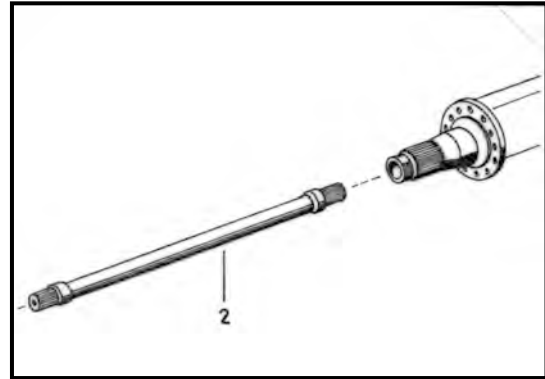
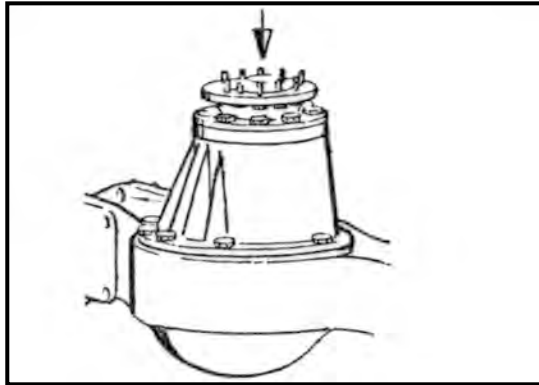

Coat the contact surface of the axle housing with Epple 33 (at version through drive with Loctite 510), and mount the complete drive assembly. The axle housing being placed in a horizontal position, secure the screws with Loctite 262. Mount the pol wheel (if present) onto the axle shaft (see 5.1.7).

Engage the axle shaft into the axle housing.

The axle shaft should be able to be moved easily (by hand) in the tothing of the differential side gear.

At version with differential lock on the outside (D 71/ D 109) the differential lock must always be actuated when assemble or disassemble the axle shaft.

Direction:

Actuating of the differential lock is necessary to prevent the sliding sleeve to drop out of the shifter fork into the axle housing when pulling out or sliding in the axle shaft. This would entail disassembly of the axle.

- Assembly of the spacer ring (if present) see sheet 5.1.6.
- Install the brake onto the axle spindle, be careful of the brake control position and bolt it.
At version with disc brake install the brake carrier (if present), then mount the wheel hub with the brake disc, and after this operation install the brake.
- Prepare and mount the wheel hub see chapter 5.5.
Attention: Hold the wheel hub with a hoist until the outer bearing with ring gear carrier is mounted.
- Assembly of the planetary gear drive see chapter 6.
- At version with drum brake mount the brake drum.
- Assembly of the ABS - sensor installation (if present) see 5.1.7.

Attention:

At version with ABS resp. ABS - preparation (the pol wheel is mounted onto the axle shaft) the thrust ring of the sun gear in the axle spindle must be dismounted for disassembly the axle shaft.

Prepare and mount the wheel hub

Prepare wheel hub

- Install the wheel studs (1).
- Press in outer rings of taper roller bearings (2 + 3), do not hammer them.
- Install inner ring of taper roller bearing (3).
- Install the face seal (4) into the wheel hub (5) (see 5.8).

Mount wheel hub

- Push the pre - assembled wheel hub (5) parallel onto the axle spindle resp. steering knuckle.

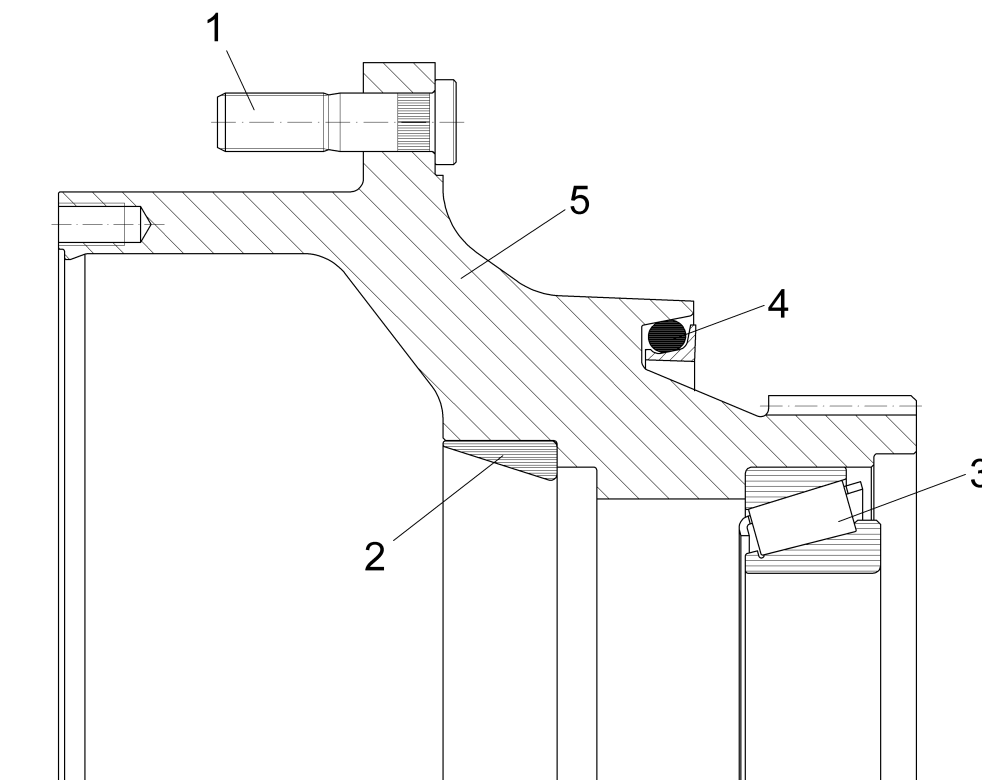

Adjustment of wheel bearings

⚠ DANGER



Wrong assembly and incorrect locking of the wheel bearing adjustment nut

The wheel together with the complete hub assembly becomes detached from the axle.

- The wheel bearing adjustment nut must absolutely be tightened and locked as described!

Tightening torque of the wheel safety nut

| serie | readjustment <u>used</u> bearings (Nm) | <u>new</u> bearings (Nm) |
|-----------|--|--------------------------|
| 81 | 450 | 500 |

Assembly wheel bearing adjustment nut

1. Completely coat the contact surface and the thread of the wheel bearing adjustment nut with assembly paste.
 - **Assembly paste with solid lubricants**
2. Screw on the wheel bearing adjustment nut and tighten with 1.5 to 2 times of the later tightening torque.
 - **Customer service tool: Wrench for wheel bearing adjustment nut**
 - **Lightly knock on the wheel hub with a plastic hammer and turn it repeatedly during tightening**
3. Loosen the wheel bearing adjustment nut again (unscrew it approximately 180 °).
4. Tighten the wheel bearing adjustment nut.
 - **Turn the wheel hub repeatedly during tightening.**
 - **Tightening torque see the table.**
 - **If it is not possible to lock in this position, the wheel bearing adjustment nut must be tightened to the next possible locking position.**

Locking wheel bearing adjustment nut

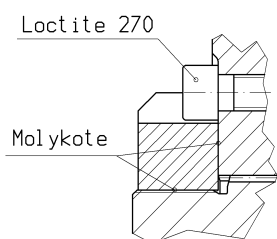

1. Lock the wheel bearing adjustment nut with a screw.
 - **Screw locking: Loctite 270**
 - **Tightening torque: 72 Nm**

Assembly of the face seal

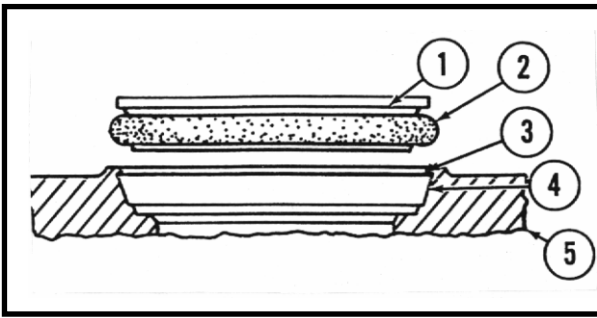

1. Seal ring
2. Rubber toric ring
3. Housing retaining lip
4. Housing ramp
5. Seal ring housing

Seal rings, torics, and housings must be clean and free of any oil film, dust, or other foreign matter. Use a solvent that evaporates quickly, leaves no residue, and is compatible with the rubber toric rings. The recommended solvent is Isopropanol. Ring and housings should be wiped with a solvent - soaked lint free cloth or paper towel.

After all components have been wiped clean, the torics should be installed on the metal seal rings so that they rest in the radius on the tail of the metal ring. Insure that the torics are not twisted by inspecting the mold flash line on the outside diameter of the toric for true circumferential tracking around the seal. Twisted torics will cause nonuniform face load that can result in leakage of lubricant and pumping of debris past the toric. If a twist is apparent, it can be eliminated by gently pulling a section of the toric radially away from the metal seal ring and letting it “snap” back. Repeating this in several places around the ring will eliminate any twist in the toric ring.

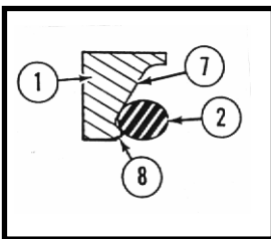

Put the toric ring (2) on seal ring (1), at the bottom of the seal ring (7) and against the retaining lip (8).

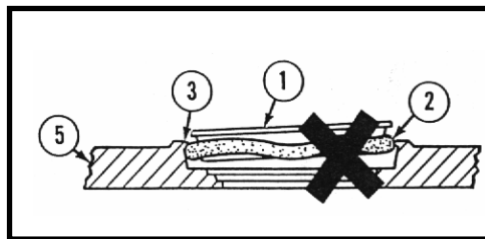

The toric ring (2) can twist if it is not wet all around during installation or if there are burrs or fins on the retaining lip (3) of the housing (5).

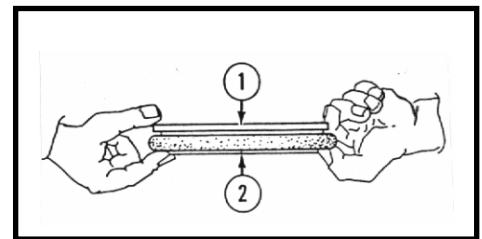

Eliminate toric twist by gently pulling a section of the toric (2) rapidly away from the seal ring (1) and letting it “snap” back.

Assembly of the face seal

Place the installation tool around the seal ring and dip the seal ring into a pan of Isopropanol solvent to lubricate the toric ring. It is essential to lubricate the toric with Isopropanol so that the toric will slip past the housing retaining lip and seal uniformly in the housing nose radius. Insufficient lubrication can cause poor seal performance due to nonuniform loading (twisted torics or cocked seals). Use of solvents other than Isopropanol can leave a residue on the toric or ramps and allow the toric to slide rather than roll in seat. This can also result in poor seal performance due to nonuniform loading.

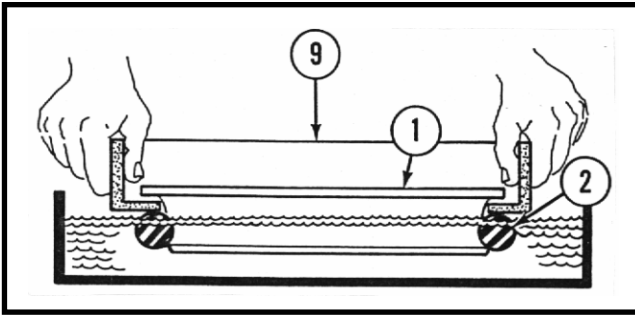

Put the installation tool (9) onto the seal ring (1) with toric ring (2). Lower the rings into a container with Isopropanol until all surfaces of the toric (2) are wet.

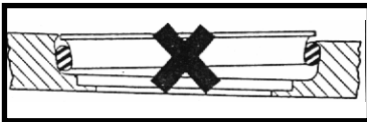

Toric sliding on retainer ramp.



Toric caught on housing retainer lip.



Toric sliding on seal ramp.

After dipping the seal assembly in the solvent, shake the excess solvent from the seal assembly and immediately “pop” the seal into the housing with a firm push of the installation tool. Remove the installation tool and check the seal stantout height at several places around the circumference of the ring to verify an accurate installation. If the seal does not meet the height specification, inspect the toric for twists or obvious bulges.

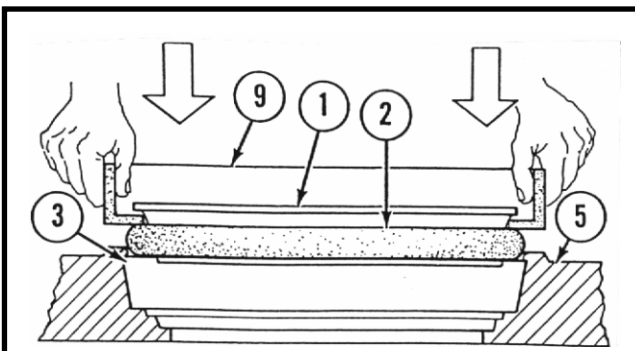

With all surfaces of the toric ring (2) wet with Isopropanol, use the installation tool (9) to position the seal ring (1) and the toric ring (2) squarely against the housing (5) as shown. Use sudden and even pressure to pop (push) the toric ring (2) under the retaining lip (3) of the housing (5).

Assembly of the face seal

The seal can be adjusted by gently pushing the toric into position by hand or by using a fabricated adjustment hook.

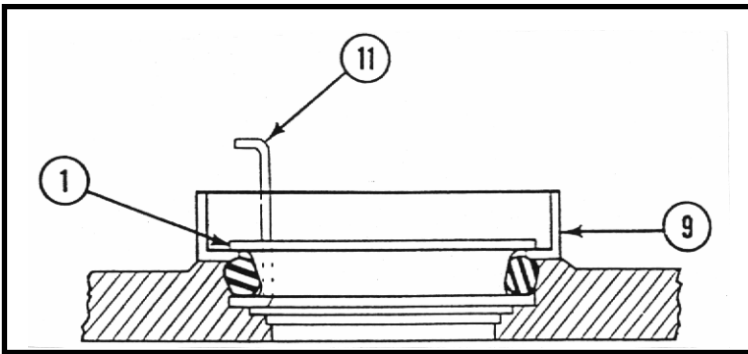

If small adjustments are necessary, do not push directly on the seal ring (1); use the installation tool (9) to push down or the adjustment tool (11) to pull up.

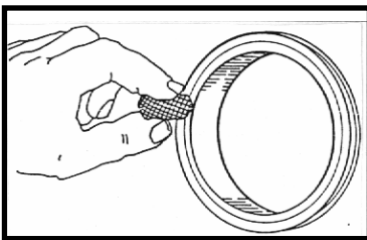

A thin film of light oil should be applied to the seal faces prior to assembly. Use an applicator, a disposable tissue or a clean finger to distribute the oil evenly. Be careful not to get any oil on the rubber toric rings.

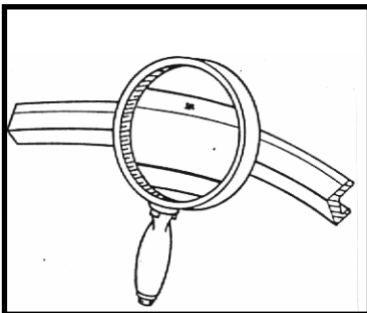

Be sure there is no visible debris on either of the seal faces - even a small piece of lint can hold the seal faces apart and cause leakage.

After successful installation, wait one minute for the Isopropanol to dry before assembling the two seal halves in the final loaded position. This delay is to allow any excess solvent to dry so that the torics roll, rather than slide, in the housing as the faceload is increased. If the torics slide, this can produce a nonuniform load that can result in poor seal performance.

Results of incorrect assembly :

Point "A" and point "B" remain stationary.

Points "X" and "Y" rotate 180°.

This causes high pressure at "A"/"Y" and possible galling.

When rotated, points "B"/"X" has low pressure and possible leakage.



Original assembled position



Rotated 180°

After the unit to be sealed is assembled, a post - assembly leakage test can be performed to insure the seal is properly installed. A vacuum check is recommended rather than a pressure check as vacuum checks are more sensitive. Many users find this an easy check to combine with a vacuum fill technique for the lubricant. It is recommended the compartment be filled to the correct level with lubricant and then rotated slowly several revolutions to seat the seals. A vacuum test will catch big seal damage such as broken seal rings or cut torics that may be caused in the last phases of assembly. The Duo - Cone seal is not designed to seal air, so some leakage can be expect using such a procedure.

Following these guidelines and recommendations should insure optimum performance from the Duo - Cone - seals.

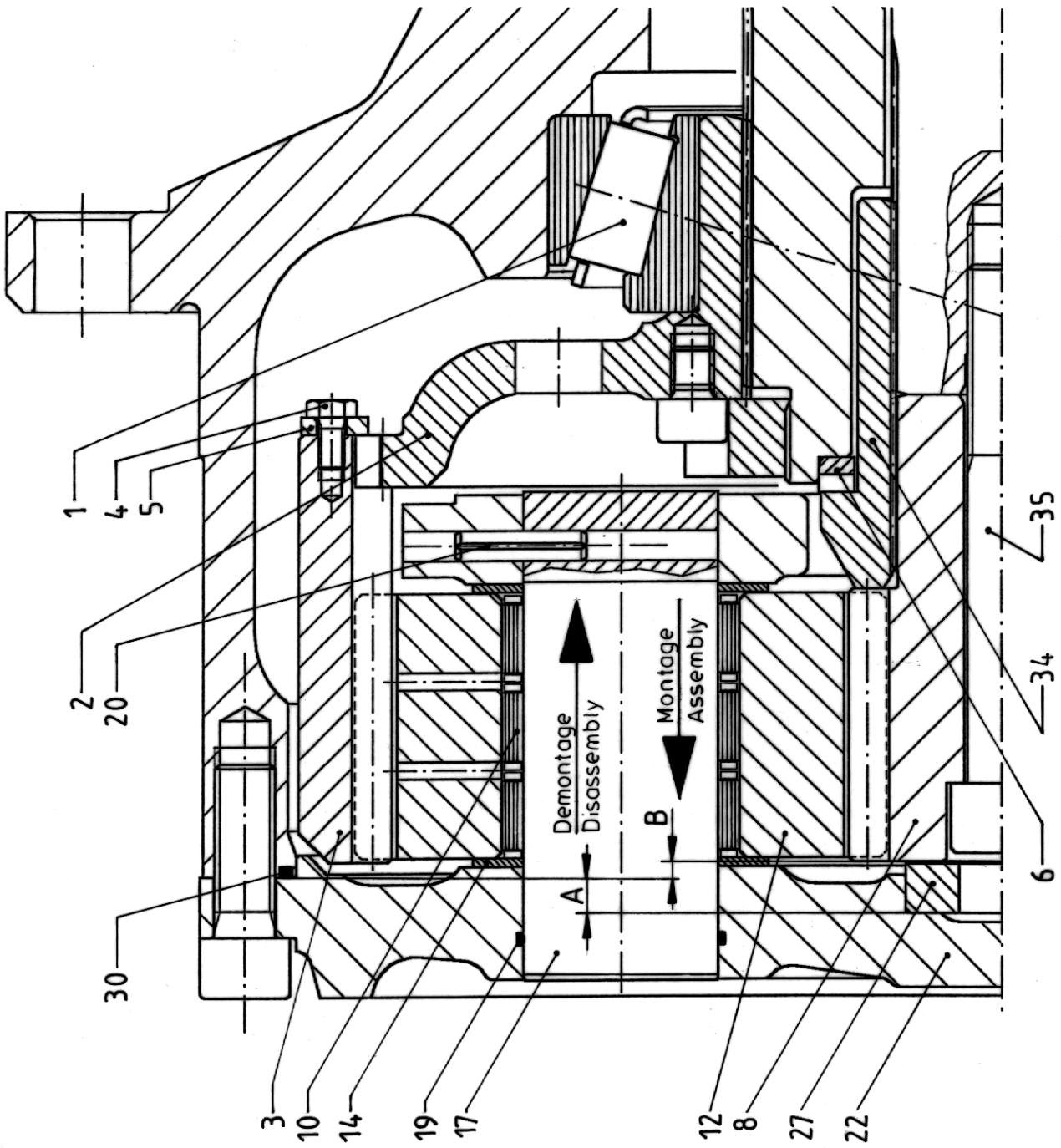

Assembly of the ring gear and ring gear carrier

Assembly of the sun gear

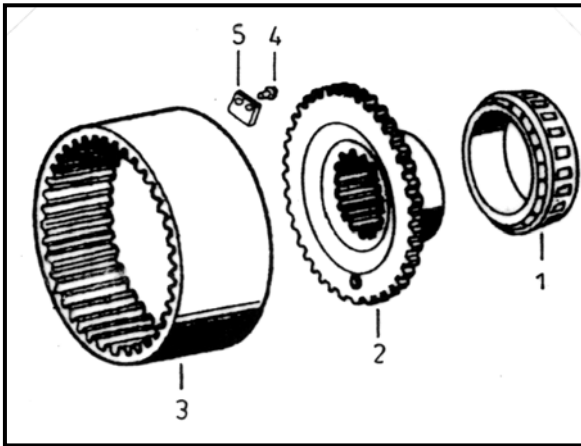

Prepare the ring gear and the ring gear carrier

Heat the taper roller bearing inner ring with cage (1) to about 100°C and install it onto the ring gear carrier (2). Place the ring gear (3) onto the ring gear carrier. Bolt the retainer (5) with the screws (4), secure the screws with Loctite 270.

Assembly of the ring gear carrier

Install the ring gear carrier (2) with ring gear (3) into the wheel hub resp. onto the steering knuckle resp. axle spindle. The oil compensating hole in the ring gear carrier must be on the bottom. Subsequent adjust wheel bearings (see chapter 5.7).

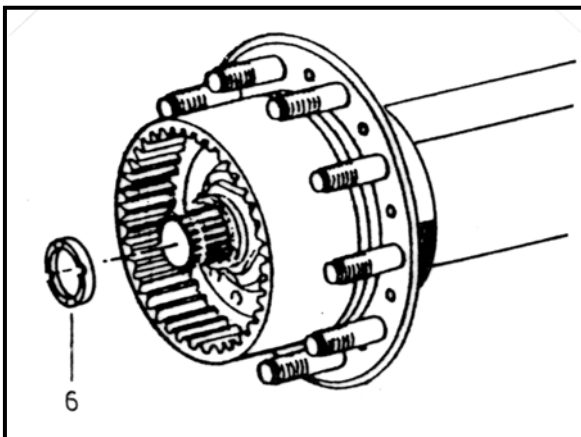

Assembly of the thrust ring

Press the thrust ring (6) into the steering knuckle resp. axle spindle. Secure with Loctite 270.

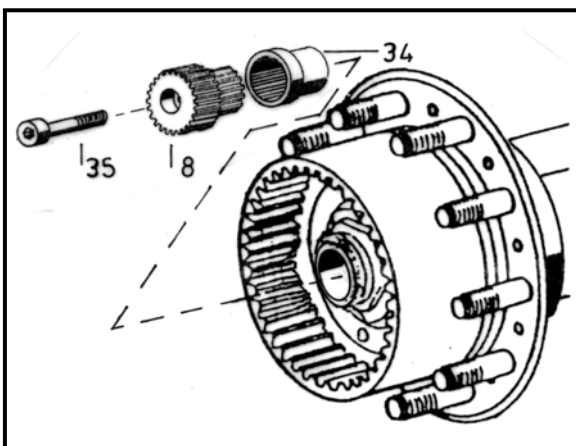

Assembly of the sun gear

Push the sleeve (34) onto the universal joint resp. axle shaft. Introduce the sun gear (8) into the sleeve and bolt it with the screw (35) onto the universal joint resp. axle shaft, secure the screw with Loctite 262. Push the universal joint resp. axle shaft towards the inside until the sun gear contacts to the sleeve and the sleeve contacts to the thrust ring.

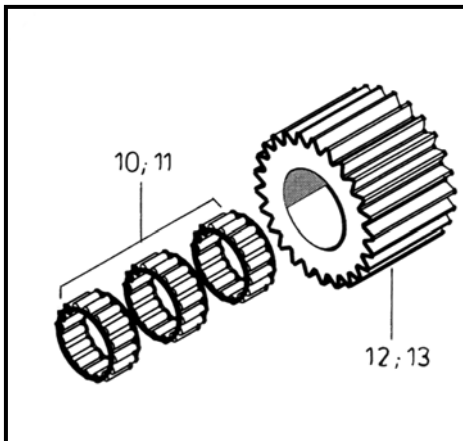

Prepare planetary gear:

Install the needle bearing (10 resp. 11) into the planetary gear (12 resp. 13).

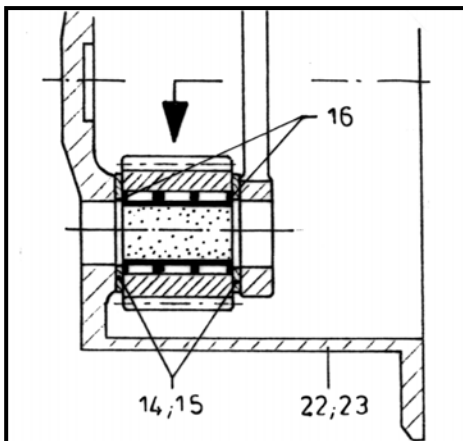

Insert the preassembled planetary gears (12 resp. 13) with needle bearings (10 resp. 11), rings (16) (if present) and thrust discs (14 resp. 15) into the planetary housing (22 resp. 23) (planetary housing in horizontal position).

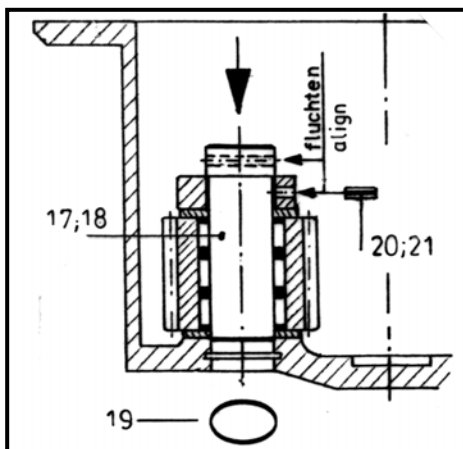

Place o - ring (19) into the slot of the planetary housing (22). Because of the difference of diameter of 0,1 mm press the planetary pin (17 resp. 18) in direction of arrow. Be sure, that the bore hole of the locking pin in the planetary pin and planetary housing are aligned. After inserting, secure the planetary pin with the locking pin (20 resp. 21).

Adjustment of the axial clearance

The axial clearance between sun gear and thrust disc (27) in the planetary housing must be 0,3 - 0,7 mm.

Measure distances:

Dimension A =

Dimension B =

Calculate required thickness, take the axial clearance (0,3 to 0,7 mm) into consideration.

Mount the correctly dimensioned thrust disc (if necessary, make final correction on a lathe) into the planetary housing. Secure with Loctite 270.

Assembly of the planetary housing

Place o - ring (30) into the slot of the planetary housing. Install the preassembled planetary housing and bolt it, secure with Loctite 262.

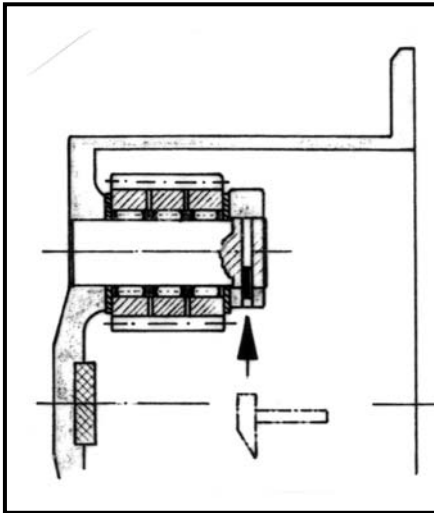

Knock the locking pin (20 resp. 21) completely to the inner side of the planetary pin.

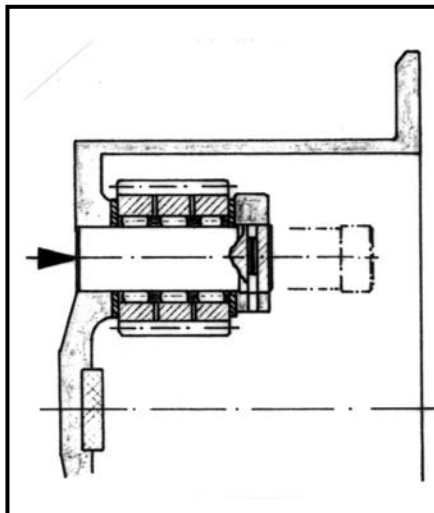

Press the planetary pin in direction of arrow out of the planetary housing.

Attention:

Because of the difference of diameter of 0,1 mm do not press the planetary pin against the direction of arrow out of the planetary housing, to prevent damaging the bore.

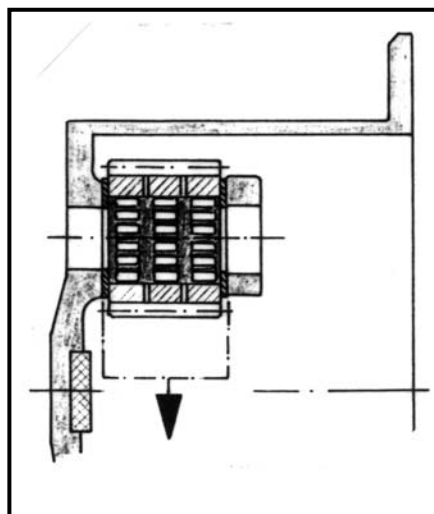

Remove the planetary gears with the thrust discs and needle bearings.

Assembly of the wet disc brake

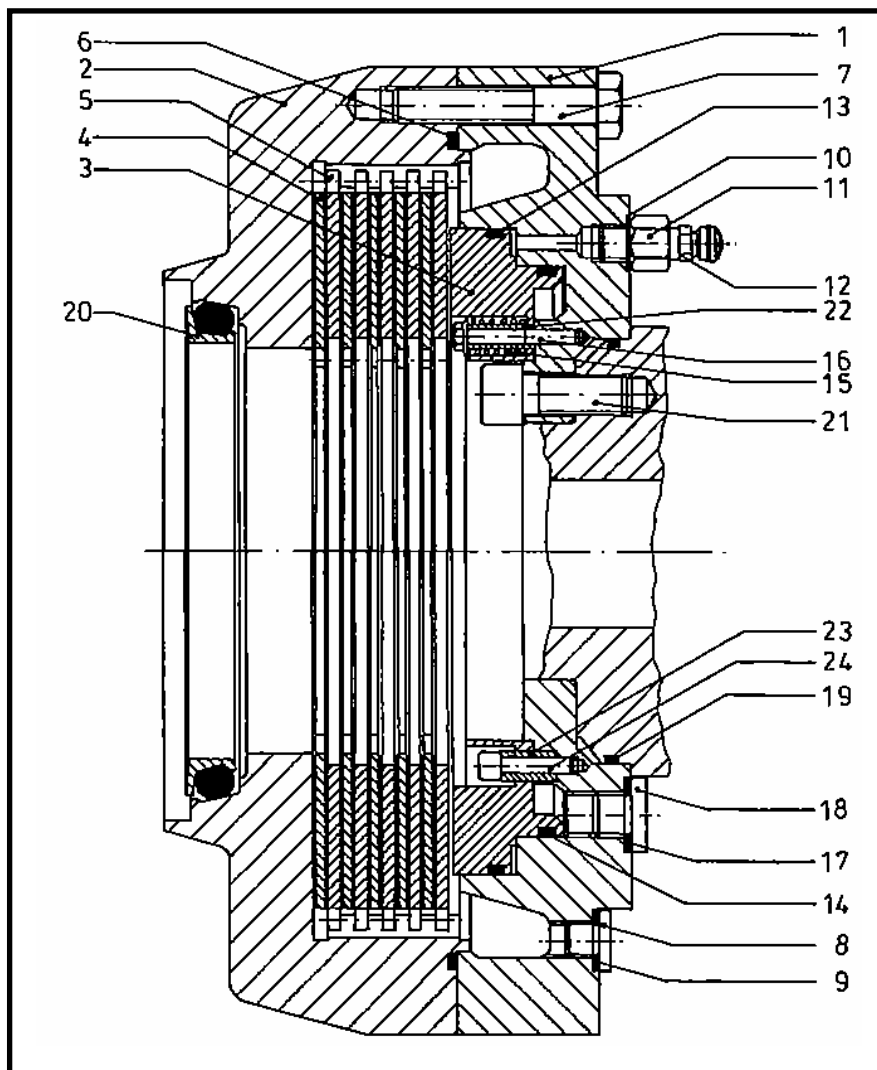

- | | |
|----------------------|------------------|
| 1. Brake carrier | 13. Sealing ring |
| 2. Brake housing | 14. Sealing ring |
| 3. Piston | 15. Spring |
| 4. Inner disc | 16. Screw |
| 5. Outer disc | 17. Seal ring |
| 6. O – ring | 18. Screw plug |
| 7. Screw | 19. O - ring |
| 8. Screw plug | 20. Face seal |
| 9. Seal ring | 21. Screw |
| 10. Seal ring | 22. Tube |
| 11. Connection peace | 23. Bushing |
| 12. Breather | 24. Screw |

Assembly of the piston seals

Place piston with the larger diameter downwards. Note succession of the sealing parts at fitting.
Install o - rings free of torsion and loops.

Assembly of o - ring and supporting ring

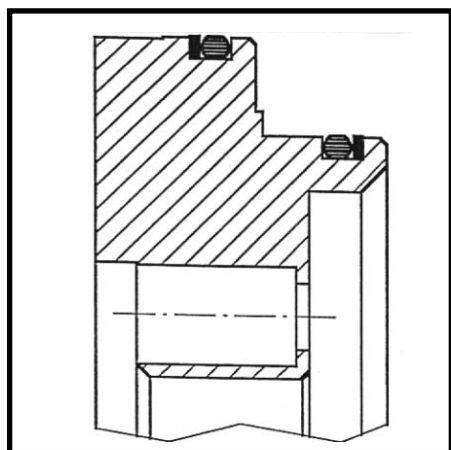

1. large supporting ring
2. large o - ring
3. small o - ring
4. small supporting ring

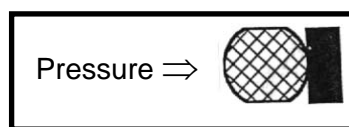

Install the supporting rings to the averting side of pressure!

Assembly of the Omegat seal kit

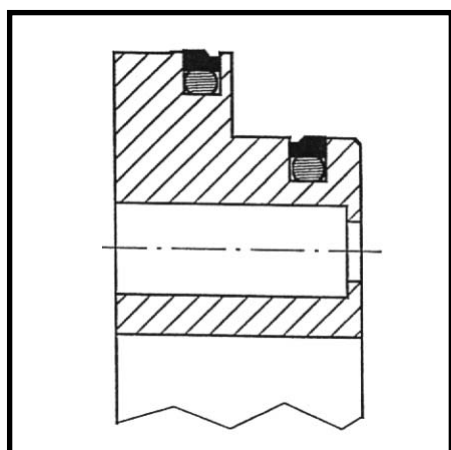

1. large o - ring
2. small o - ring
3. large supporting ring
4. small supporting ring

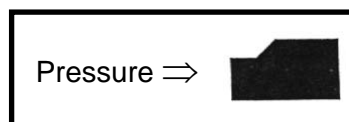

Install the PTFE - profile rings with small diameter to pressure side!

Assembly of the piston

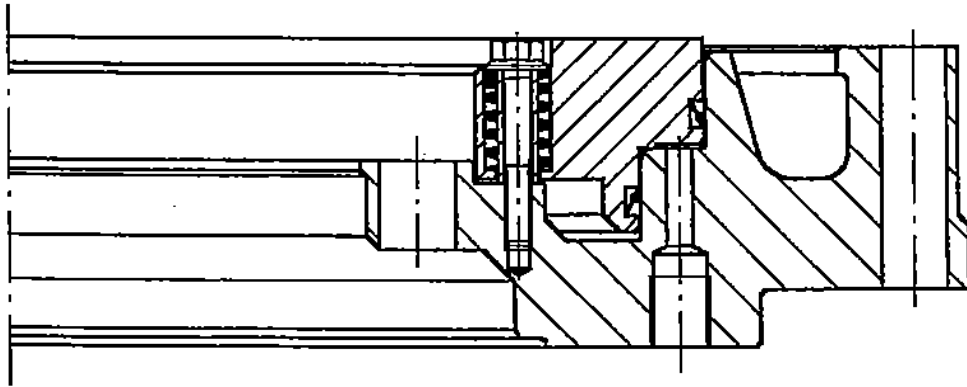

- lubricate cylinder bore
- apply the thread holes at wet disc brakes with Loctite

| | | |
|------------------------------------|--------------------|---------------------------|
| Wet disc brake (dimension X...) | X270 - X340 | X460 – X550 – X650 |
| use | Loctite 243 | Loctite 262 |

- install and screw the bushing (if present)
- place the piston onto the brake carrier (do not cant it!)

| | | |
|------------------------------------|---|--|
| Wet disc brake (dimension X...) | X270 - X340 | X460 – X550 – X650 |
| Assembly of the piston | press the piston equal by hand into the brake carrier (do not cant it!) | press the piston equal with mounting screws into the brake carrier (do not cant it!) |

- if necessary adjust the piston with easy hammer taps to the thread holes
- install first the springs, then the tubes in the bore holes of the piston
- screw in the hexagon head screws with flange

Prepare housing and check the air gap

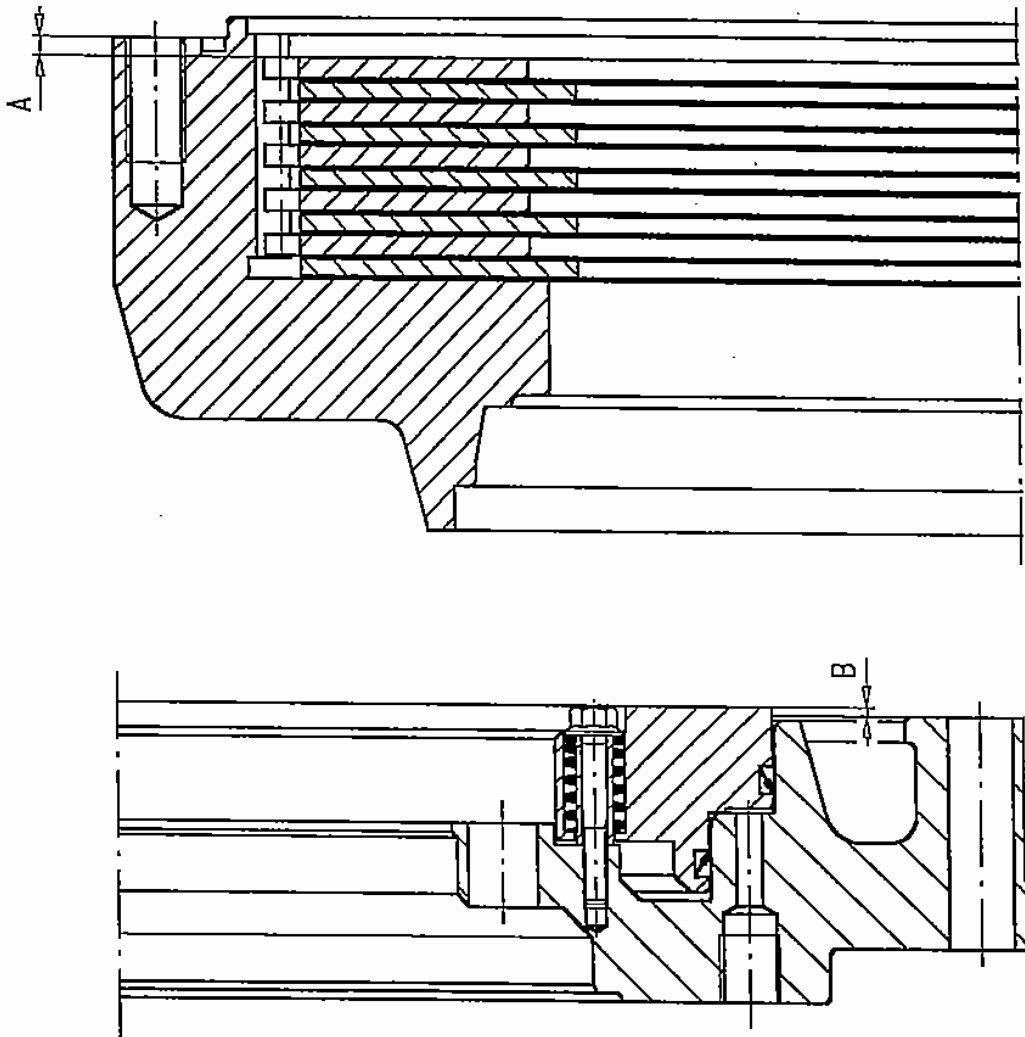

Lay discs into the housing.

Check the air gap:

Air gap = measure A - measure B (measured without pressure)

Rated size about 0,5 mm smaller than the air gap pressurized (see table).

Install o - ring (brake housing/ brake carrier) free of torsion and loops.

Air gap and wear dimension

| brake type | air gap sL new (pressurized) (mm) | wear dimension (mm) |
|------------|---|------------------------|
| 3270 | 1,5 ± 0,7 | 1,5 |
| 3340 | 2,4 ± 0,6 | 1,5 |
| 3340-1 | 1,8 + 0,5/ - 0,1 | 1,5 |
| 4340 | 2,5 ± 0,9 | 2,0 |
| 5340 | 2,4 ± 0,9 | 2,5 |
| 6340 | 2,8 ± 0,6 | 3,0 |
| 3460 | 2,5 + 0,7/ - 0,1 | 1,5 |
| 4460 | 2,5 + 0,7/ - 0,1 | 2,0 |
| 4460-1 | 2,25 + 1/ - 0,1 | 2,0 |
| 5460 | 3,0 + 0,5/ - 0,1 | 2,5 |
| 6460 | 3,0 + 0,5/ - 0,1 | 3,0 |
| 7460 | 3,0 + 0,5/ - 0,1 | 3,5 |
| 8460 | 3,3 + 0,5/ - 0,1 | 4,0 |
| 10460 | 4,0 + 0,5/ - 0,1 | 5,0 |
| 5550 | 3,0 + 0,5/ - 0,1 | 2,5 |
| 8550 | 3,5 + 0,5/ - 0,1 | 4,0 |
| 4650-1 | 3,5 + 0,5/ - 0,1 | 2,0 |
| 6650-1 | 4,0 + 0,5/ - 0,1 | 3,0 |

Place the brake carrier onto the brake housing and bolt it. Mount breather with connection piece and seal ring, screw plugs with seal rings.

Check brake hydraulik system for leaks (see tightness checking instruction).

Install o - ring (Brake carrier/ axle spindle resp. steering knuckle) free of torsion and loops.

Check the air gap (pressurized):

Measure through the check hole the distance from brake carrier to the piston end face, while non actuated brake, actuate the brake and repeat the measure operation - the difference of the measured distances gives the air gap sL (pressurized), rated size sL see table.

Measure through the check hole the distance from brake carrier to the piston end face, while actuating the brake and knock the measured value with marking punches into the brake carrier.

Install the complete brake on the axle (coat the contact surface with Loctite 270).

Mount face seal see chapter 5.8.

Alignment of the discs

Wet disc brake dimension X270 and X340:

The alignment of the discs has to be made at mounting of the wheel hub by itself.

Wet disc brake dimension X460 and X650:

The alignment of the discs has to be made by a mounting device (see chapter 3.6). Clamp the discs by actuating the brake (hydraulic or air pressure).

Tightness checking instruction for brake hydraulic system and cooling oil room

Check brake hydraulic system for leaks

Before conducting the test, bleed the brake hydraulic system.

The pressure drop after applying 120 bar for a period of 15 minutes must not exceed 2% (leaving 117,5 bar).

Test medium: Motor oil SAE 10 W corresponding to MIL - L 2104.

Check cooling oil room for leaks

Brake with external cooling:

After assembly of the wheel hub with the face seal and adjusting of the wheel bearings check the tightness of the cooling oil room.

Install an air pressure gauge with shutoff valve.

Beload the hub assembly with 1,5 bar pressure air.

Turn the hub assembly several times.

The pressure drop after a period of 10 minutes must not exceed 0,1 bar.

Brake without external cooling:

After assembly of the planetary gear drive check the tightness of the cooling oil room.

Install an air pressure gauge with shutoff valve.

Beload the hub assembly with 0,5 bar pressure air.

Turn the hub assembly several times.

The pressure drop after a period of 15 minutes must not exceed 0,1 bar.

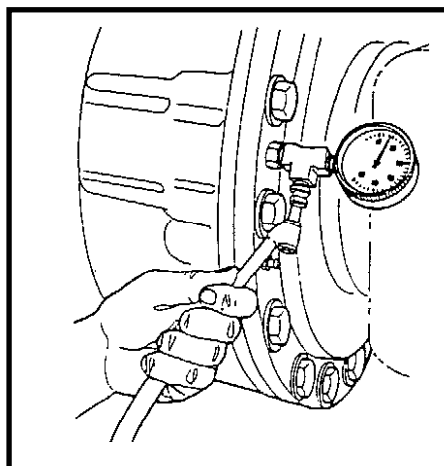

Remarks to the wet disc brake

Permissible oil for brake without external cooling (oil sump = cooling fluid)

Actuation fluid:

Do not use brake fluid at any time!

Use a mineral oil base hydraulic oil type fluid only!

- 1) Motoroil API SE/ CD
 MIL - L - 46152C/ MIL - L - 2104 C o. D
- 2) ATF C - 3 or Dexron ®
- 3) Hydraulicoil HLP DIN 51524 Teil 2

Viscosity:

For moderate climate ISO VG 22 - 32

For extremely cold climate ISO VG 15

For extremely warm climate ISO VG 46

Cooling fluid:

Hypoid gear oil like specification on installation drawing:

SAE 90 per MIL - L - 2105 B , API GL 5.

Important: It is necessary to use oils with LS - additives (Limited Slip), according to the recommendation of the oil supplier.

For example: 3 - 6% Lubrizol LZ 6178

Check measure:

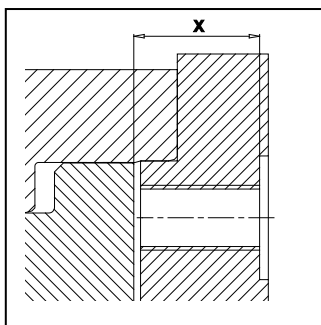

It is measured through the check hole, while actuating the brake.

The check measure, new, is marked in the housing below the hole.

Is the marked dimension bigger than the measured dimension and max. wear dimension, unconditional consult RICO & Co.

After working at the brake, bleed the brake hydraulic system and check for tightness!

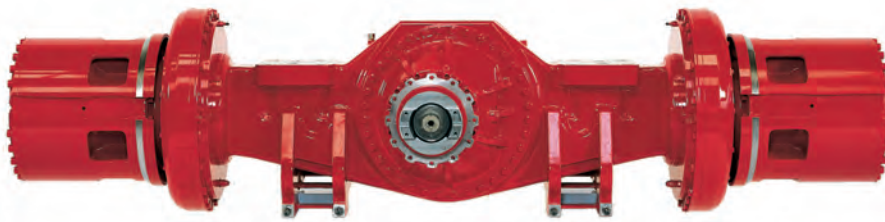

RICO