

Single Reduction Rear Differential Carriers

Maintenance Manual 5A

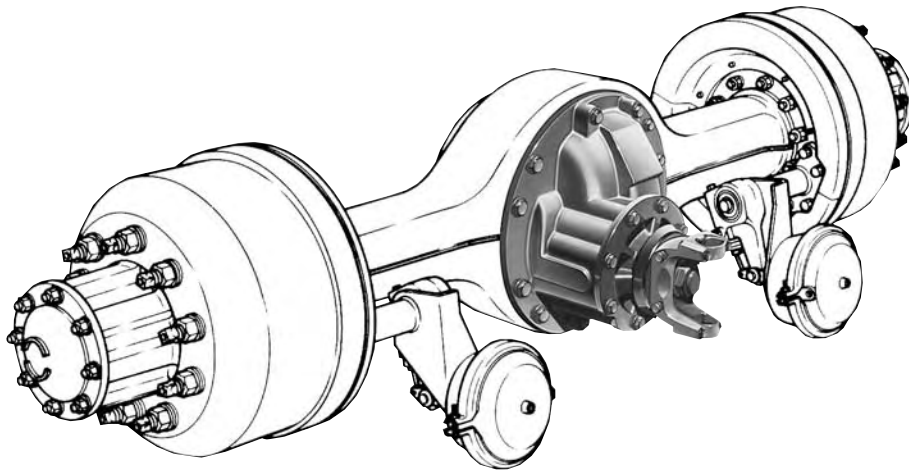

RS and RT Series
Single Reduction
Axles



RF Series Front
Drive Axles
(Single, Rear of Tandem,
Front Drive Steering)

Before You Begin

This manual provides instructions for Meritor's RS-, RT-, and RF-Series axles. Before you begin procedures:

1. Read and understand all instructions and procedures before you begin to service components.
2. Read and observe all Caution and Warning safety alerts that precede instructions or procedures you will perform. These alerts help to avoid damage to components, serious personal injury, or both.
3. Follow your company's maintenance and service, installation, and diagnostics guidelines.
4. Use special tools when required to help avoid serious personal injury and damage to components.

Safety Alerts, Torque Symbol and Notes

 WARNING	A Warning alerts you to an instruction or procedure that you must follow exactly to avoid serious personal injury and damage to components.
 CAUTION	A Caution alerts you to an instruction or procedure that you must follow exactly to avoid damage to components and possible serious injury.
	A torque symbol alerts you to tighten fasteners to a specified torque value.
NOTE	A Note provides information or suggestions that help you correctly service a component.

Axle Models Covered in this Manual

Single Drive Axles				For other models (non RS-, RT- and RF-Series), refer to Maintenance Manual 5, Single Reduction Differential Carriers.
RS-13-120	RS-17-144	RS-23-160A	RS-25-160A	
RS-15-120	RS-17-145	RS-23-161	RS-26-160	
RS-16-140	RS-19-144	RS-23-161A	RS-26-180	
RS-16-141	RS-19-145	RS-23-180	RS-26-185	
RS-16-145	RS-21-145	RS-23-185	RS-30-180	
RS-17-140	RS-21-160	RS-23-186	RS-30-185	
RS-17-141	RS-23-160	RS-25-160		
Rear Axle of Tandem Axles				
RT-34-140	RT-40-145P	RT-46-160	RT-50-160	
RT-34-144	RT-40-146	RT-46-160A	RT-50-160P	
RT-34-145	RT-40-160	RT-46-160P	RT-52-180	
RT-34-145P	RT-40-169	RT-46-164	RT-52-185	
RT-34-146	RT-44-145	RT-46-164EH	RT-58-180	
RT-40-140	RT-44-145P	RT-48-180	RT-58-185	
RT-40-145A	RT-44-149	RT-48-185		
Front Drive Steering Axles				
RF-7-120	RF-16-145	RF-21-160	RF-22-166	
RF-9-120	RF-21-155	RF-21-185	RF-23-180	
RF-12-120	RF-21-156	RF-21-355	RF-23-185	
RF-12-125				

Table of Contents

Section 1: Introduction	1
Standard Single Reduction Carriers Without Differential Lock	1
Single Reduction Carriers with DCDL (Driver-Controlled Main Differential Lock)	2
Section 2: Disassembly	3
Remove Differential Carrier from Axle Housing	3
Brass Drift Method	5
Air Hammer Vibration Method	5
Carrier Removal from Axle	6
Remove the Differential and Ring Gear from the Carrier	8
Disassemble the Differential and Ring Gear Assembly	10
Remove the Drive Pinion and Bearing Cage from Carrier	12
Disassemble the Drive Pinion and Bearing Cage	13
Section 3: Preparing the Parts for Assembly	17
Clean and Inspect Yokes	17
Cleaning Ground and Polished Parts	18
Cleaning Rough Parts	18
Cleaning Axle Assemblies	18
Drying Parts After Cleaning	18
Preventing Corrosion on Cleaned Parts	19
Inspecting Parts	19
Repair or Replacement of Parts, General	21
Repair Axle by Welding	21
Bending or Straightening Drive Axle Housings	22
Removing Dri-Loc® Fasteners	22
Section 4: General Information	23
Installing Fasteners with Pre-applied Adhesive, RICO Liquid Adhesive 2297-C-7049, Loctite® 680 Liquid Adhesive or Equivalent	23
Installing New Fasteners with Pre-applied Adhesive Patches	23
Installing Original or Used Fasteners Using RICO Liquid Adhesive 2297-C-7049 or Loctite® 680 or Equivalent	23
Application of RICO Adhesive 2297-T-4180 in Bearing Bores for the Differential	24
Application of Three Bond 1216 or Equivalent Silicone Gasket Material	24
Installing Tight Fit Yokes and POSE™ Seal	25
Installing Any Type Yoke with a Unitized Pinion Seal (UPS)	26
Clean, Inspect and Install the Yoke After Installing a Unitized Pinion Seal	28
General Yoke and U-Joint Reassembly	29
Gear Set Information (Drive Pinion and Ring Gear Marks)	29
Section 5: Assembly	31
Assemble the Drive Pinion, Bearings and Bearing Cage	31
Adjusting Preload of Pinion Bearings	36
Press Method	36
Yoke or Flange Method	38
Adjusting Shim Pack Thickness for the Pinion Cage (Depth of Pinion)	41
Installing the Drive Pinion, Bearing Cage and Shim Pack into the Carrier	43
Installing Tight Fit Yokes and POSE™ Seal	44
Installing Any Type Yoke with a Unitized Pinion Seal (UPS)	45
Clean, Inspect and Install the Yoke After Installing a Unitized Pinion Seal	46
Assemble the Main Differential and Ring Gear Assembly	48
Rotating Resistance Check of Differential Gears	51
Install the Differential and Ring Gear Assembly	52
Adjust Preload of Differential Bearings	53
Check Runout of Ring Gear	56
Ring Gear Backlash Adjustment	56
Checking Tooth Contact Patterns (Backlash) of the Gear Set	58
General Information	58
Tooth Contact Patterns of Generoid Hypoid Gear Sets	59
Install and Adjust the Thrust Screw	62
Install Differential Carrier into Axle Housing	63
Straight Holes, Nuts and Hardened Washers	64
Tapered Dowel, Hardened Washer and Hardened Nut	65

Table of Contents

Section 6: Driver-Controlled Main Differential Lock	66
Driver-Controlled Main Differential Lock Assembly	66
Removing the Differential Carrier from Axle Housing	67
Axle Setup for DCDL Disassembly	67
DCDL Assembly Manual Engaging Methods	68
Removal of the Differential and Gear Assembly	69
Removing the Differential Lock Sliding Collar	69
Installation of the DCDL Assembly into Carrier	71
Bolt-On Style Differential Lock Assembly	71
Screw-In Style Differential Lock Assembly	74
Differential Lock Assembly Cover Plates	75
Installing the Carrier into Axle Housing	76
Manual Engaging Method	76
Check the Differential Lock	78
Driver Caution Label	78
Traction Control Video Package	78
Section 7: Lubrication	79
Lubricant Capacities	80
Section 8: Fastener Torque Information	81
Torque Values for Fasteners	81
General Information	81
American Standard Fasteners	81
Metric Fasteners	81
Section 9: Adjustments and Specifications	86
Section 10: Vehicle Towing Instructions	88
TYPES OF AXLES:	
• SINGLE AXLE, with Driver Controlled Main Differential Lock (DCDL – Screw-In [threaded] shift assembly)	88
• TANDEM AXLE, with Driver Controlled Main Differential Lock (DCDL – Screw-In [threaded] shift assembly) and with Inter-Axle Differential (IAD)	88
• SINGLE AXLE, with Driver Controlled Main Differential Lock (DCDL – Bolt-On shift assembly)	94
• TANDEM AXLE, with Driver Controlled Main Differential Lock (DCDL – Bolt-On shift assembly) and with Inter-Axle Differential (IAD)	94
• SINGLE AXLE, without Driver Controlled Main Differential Lock (DCDL)	101
• TANDEM AXLE, without Driver Controlled Main Differential Lock (DCDL), with Inter-Axle Differential (IAD)	101

Single Reduction Differential Carrier

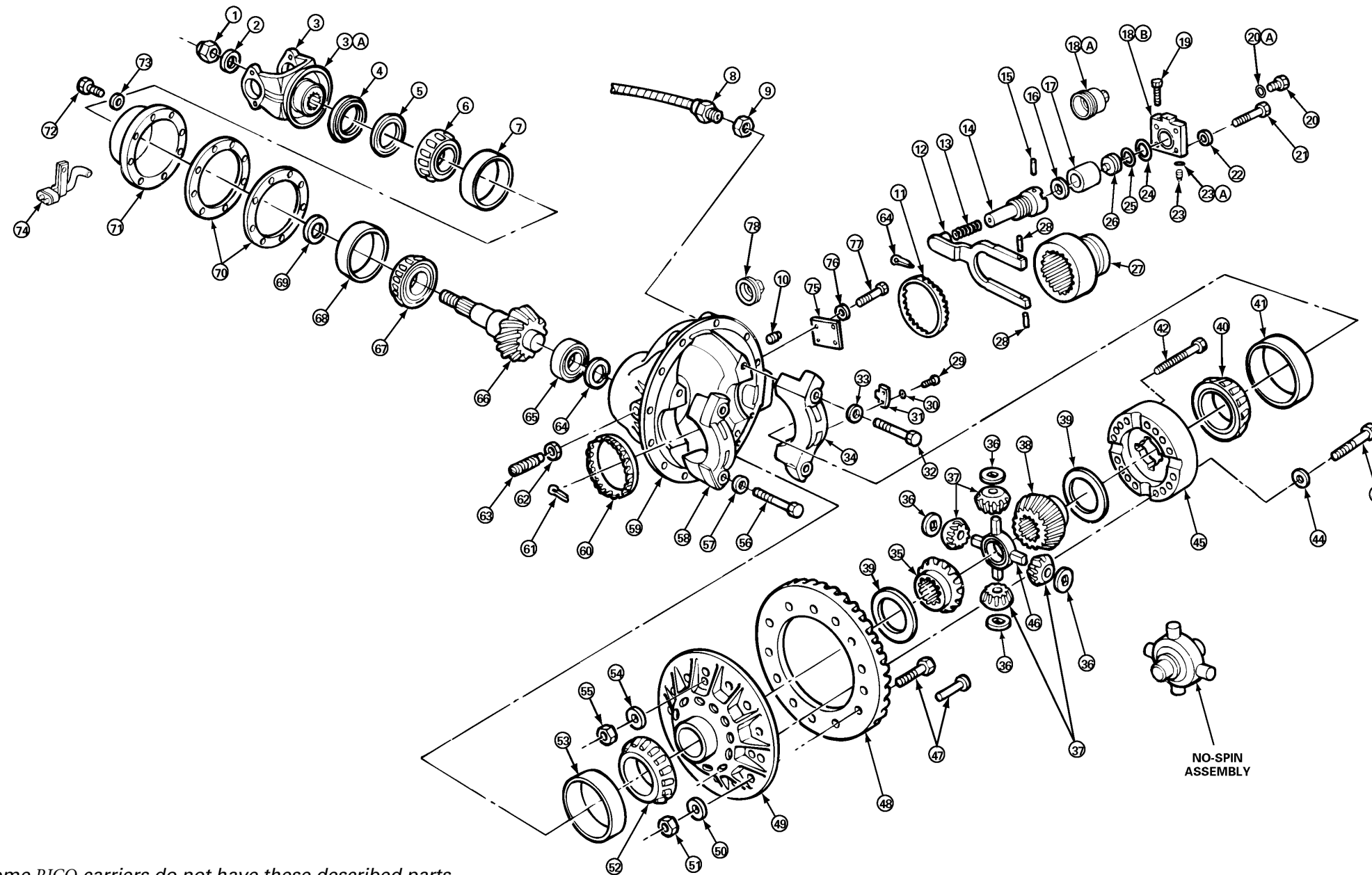

*Some RICO carriers do not have these described parts.

1 Nut — Drive Pinion*	16 Washer* or Silastic* — Air Cylinder	29 Capscrews* — Lock Plate*	42 "Thru" Bolt	56 Capscrews — Differential Bearing Cup
2 Washer — Drive Pinion*	17 Tube — Air Cylinder	30 Washers* — Lock Plate*	43 Bolts* — Differential Case	57 Washers
3 Input Yoke* or Flange*	18A Screw-In Differential Lock Cylinder	31 Lock Plate — Adjusting Ring	44 Washers — Differential Case	58 Caps — Differential Bearing
3A Deflector	18B Cylinder Cover	32 Capscrews — Differential Bearing Cap	45 Case Assembly — Main Differential	59 Carrier
4 POSE™ seal	19 Capscrew — Manual Actuation	33 Washers	46 Spider — Differential	60 Adjusting Ring
5 Triple Lip (Main) Seal	20 Plug — Cylinder Cover	34 Caps — Differential Bearing	47 Bolts* or Rivets* — Ring Gear and Case Half	61 Cotter Pin — Adjusting Ring
6 Bearing Cone — Outer	20A Gasket — Cover Plug	35 Side Gears — Differential	48 Ring Gear (Pinion Drive Gear)	62 Jam Nut* — Thrust Screw*
7 Bearing Cup — Inner	21 Capscrews — Cylinder Cover	36 Thrust Washers — Differential Pinion	49 Case Half — Flange	63 Thrust Screw*
8 Sensor Switch	22 Washers — Cylinder Cover	37 Pinions — Differential	50 Washers — Case Half	64 Snap Ring
9 Lock Nut — Sensor Switch	23 Plug — Cylinder Cover	38 Differential — Side Gears	51 Nuts* — Case Half	65 Spigot Bearing
10 Plug	23A Gasket — Cover Plug	39 Thrust Washers — Differential Side Gear	52 Bearing Cone — Differential L.H.	66 Drive Pinion
11 Adjusting Ring — R.H.	24 Copper Gasket — Cylinder Cover	40 Cone — Differential Bearing	53 Bearing Cup — Differential L.H.	67 Bearing Cone — Pinion Inner
12 Shift Fork	25 O-Ring — Piston	41 Cup — Differential Bearing	54 Washer for "Thru" Bolt	68 Bearing Cup — Pinion Inner
13 Spring — Shift Shaft	26 Piston		55 Nut for "Thru" Bolt	69 Spacer — Pinion Bearing
14 Shift Shaft	27 Shift Collar			70 Shims
15 Pin — Spring Retaining	28 Pins — Shift Fork			71 Bearing Cage — Drive Pinion
				72 Capscrew — Bearing Cage
				73 Washer
				74 Clip and Cable Holder
				75 Cover — Bolt-On
				76 Washer
				77 Bolt
				78 Cover — Screw-In

Standard Single Reduction Carriers Without Differential Lock

RICO single reduction standard carriers, **Figure 1.1**, are used in most RICO single axles, rear of tandem axles and front drive steering axles.

The single reduction carrier models are front mounted into the axle housing. These carriers have a hypoid drive pinion and ring gear set and bevel gears in the differential assembly.

A straight roller bearing (spigot) is mounted on the head of the drive pinion. All other bearings in the carrier are tapered roller bearings.

When the carrier operates, there is normal differential action between the wheels all the time.

Figure 1.1

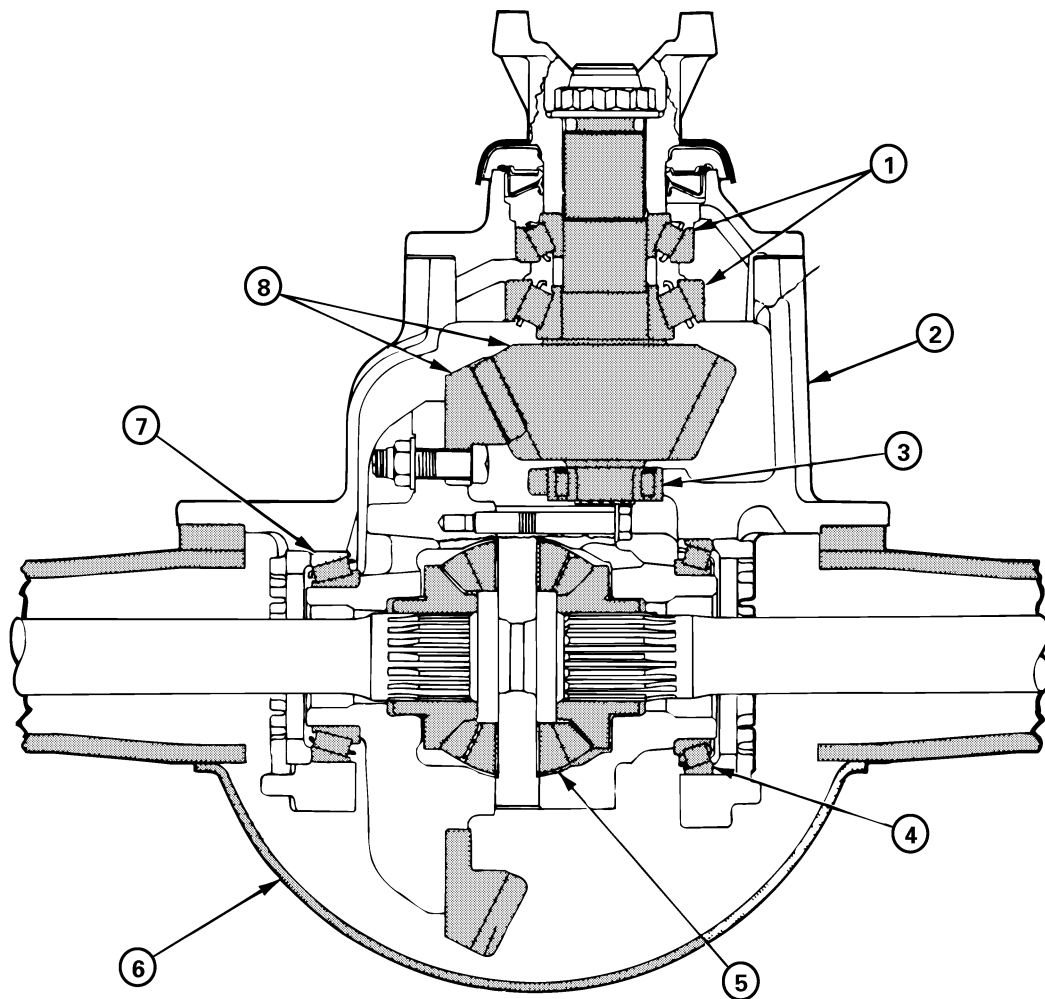

1002981a

- 1 TAPERED ROLLER BEARINGS
- 2 CARRIER
- 3 STRAIGHT ROLLER BEARING
- 4 TAPERED ROLLER BEARING
- 5 BEVEL DIFFERENTIAL GEARS
- 6 HOUSING
- 7 TAPERED ROLLER BEARING
- 8 HYPOID DRIVE PINION AND RING GEAR

Section 1

Introduction

Single Reduction Carriers with DCDL (Driver-Controlled Main Differential Lock)

RICO single reduction carriers with Differential Lock, **Figure 1.2**, have the same type of gears and bearings as the standard type carriers.

The differential lock is operated by an air actuated shift assembly that is mounted on the carrier. When the differential lock is activated, the shift

collar is moved along the splines of the axle shaft toward the differential case. When the splines on the collar are engaged with splines on the differential case the axle shafts and differential assembly are locked together. When the carrier operates in the locked position, there is no differential action between the wheels. When the carrier is operated in the unlocked position, there is normal differential action between the wheels all the time.

Figure 1.2

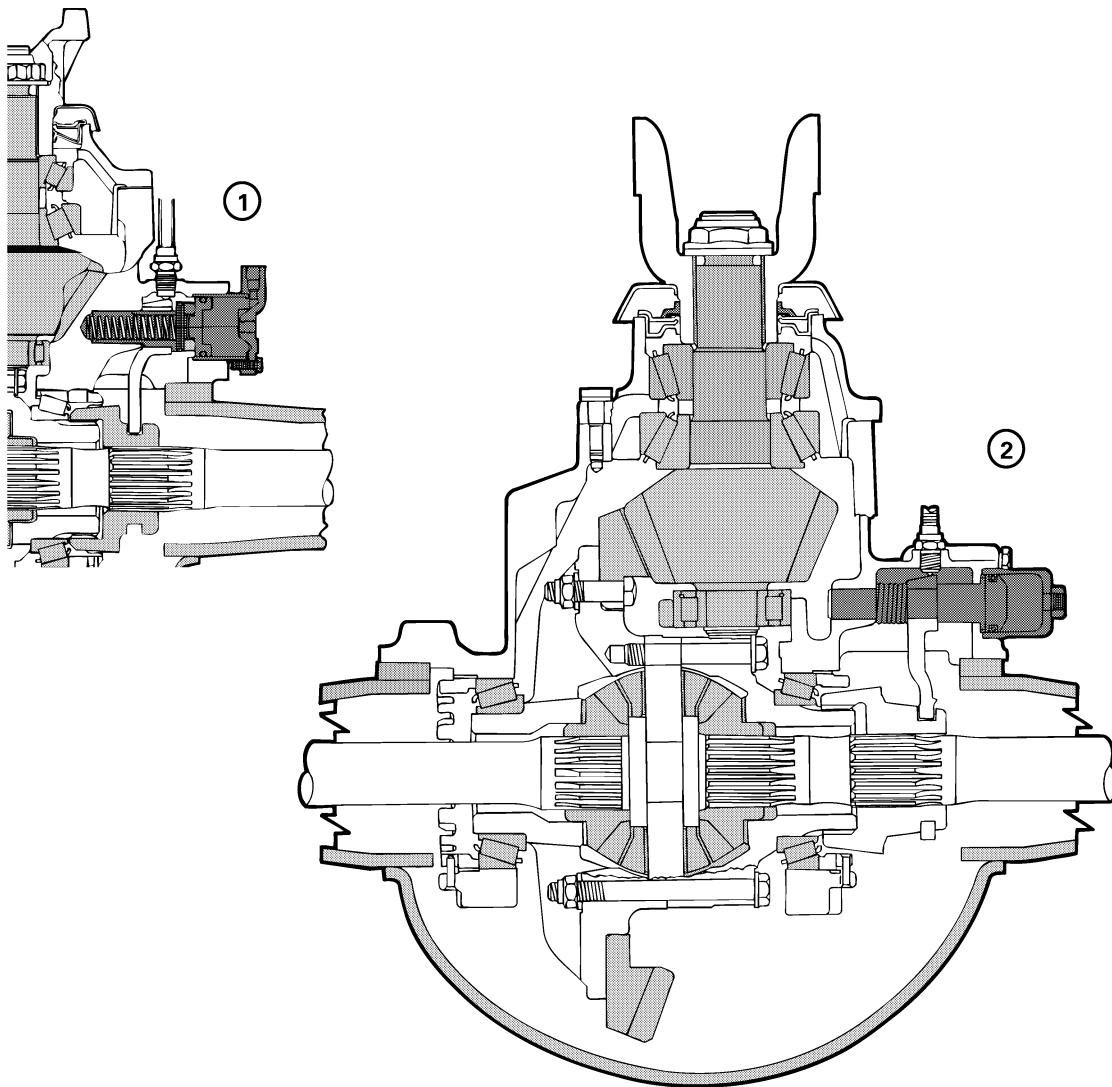

- 1 BOLT-IN STYLE
- 2 SCREW-IN STYLE (THREADED)

STANDARD CARRIER WITH DIFFERENTIAL LOCK (DCDL)

1000982a

Remove Differential Carrier from Axle Housing

⚠ WARNING

To prevent serious eye injury, always wear safe eye protection when you perform vehicle maintenance or service.

NOTE

If the vehicle is equipped with a driver-controlled main differential lock, the DCDL collar must be engaged before removing axle shafts. Refer to complete instructions in "Driver-Controlled Main Differential Lock Assembly" and Figure 6.1.

1. Raise the end of vehicle where the axle is mounted. Use a jack or other lifting tool, and place safety stands under each side of the axle. **Figure 2.1.**

⚠ WARNING

Block the wheels to prevent the vehicle from moving. Support the vehicle with safety stands. Do not work under a vehicle supported only by jacks. Jacks can slip and fall over. Serious personal injury can result.

2. Place jack stands under each spring seat of the axle to hold vehicle in the raised position. **Figure 2.1.**
3. Remove the plug from bottom of axle housing and drain lubricant from the assembly.

Figure 2.1

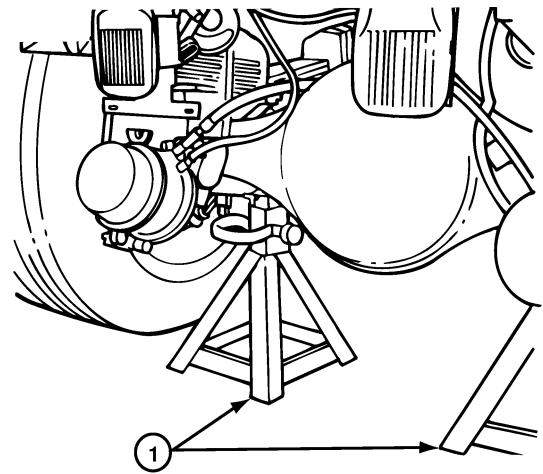

1002983a

1 SAFETY STANDS

Section 2 Disassembly

4. Disconnect the driveline universal joint from the pinion input yoke or flange on the carrier.
Figure 2.2.
5. Remove the capscrews* and washers or stud nuts* and washers from the flanges of both axle shafts.

Figure 2.2

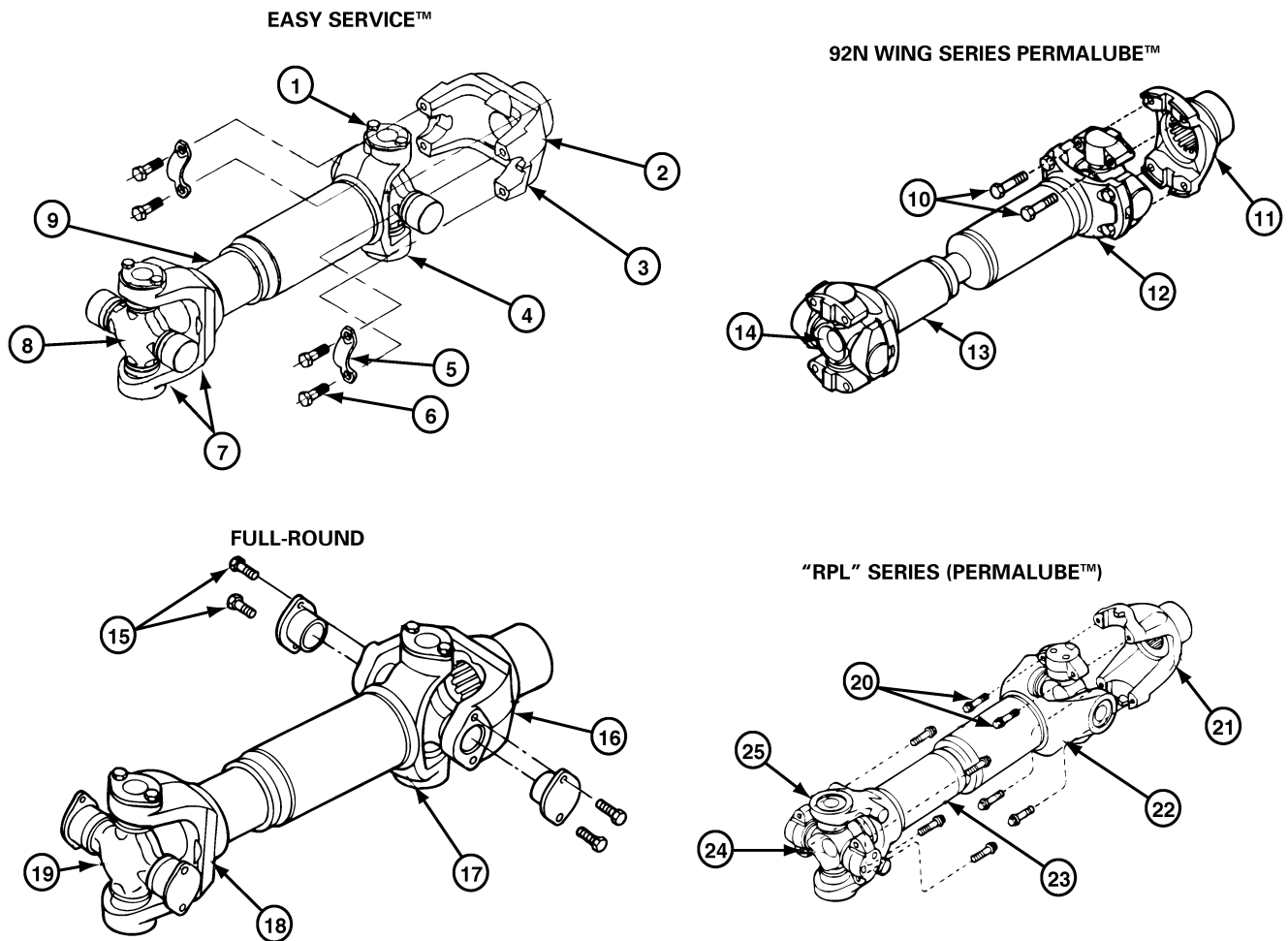

- 1 FULL ROUND BEARING CUPS
- 2 END YOKE
- 3 YOKE SADDLE
- 4 WELD YOKE
- 5 BEARING STRAP
- 6 CAPSCREWS
- 7 EASY-SERVICE BEARING CUPS
- 8 U-JOINT CROSS
- 9 SLIP YOKE
- 10 CAPSCREWS
- 11 END YOKE
- 12 WELD YOKE
- 13 SLIP YOKE

- 14 U-JOINT CROSS
- 15 CAPSCREWS
- 16 END YOKE
- 17 WELD YOKE
- 18 SLIP YOKE
- 19 U-JOINT CROSS
- 20 CAPSCREWS
- 21 END YOKE
- 22 SLIP YOKE
- 23 TUBING
- 24 U-JOINT CROSS
- 25 WELD YOKE

1002984a

Section 2 Disassembly

- Loosen the tapered dowels* in the axle flanges of both axle shafts using one of the following methods.

Brass Drift Method

WARNING

Do not strike the round driving lugs on the flange of an axle shaft. Pieces can break off and cause serious personal injury.

- Hold a 1-1/2-inch diameter brass drift against the center of the axle shaft, inside the round driving lugs. **Figure 2.3.**

Figure 2.3

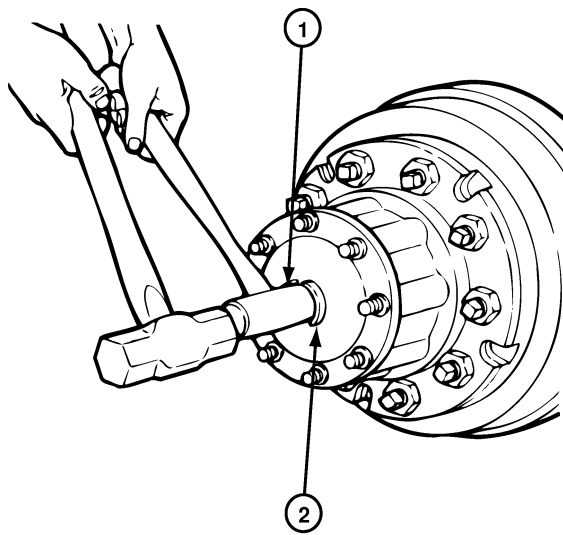

1002985a

- BRASS HAMMER**
- DRIVING LUGS**

NOTE

A 1-1/2 inch diameter brass hammer can be used as a drift.

- Strike the end of the drift with a large hammer (five to six pounds) and the axle shaft and tapered dowels will loosen.
- Mark to identify each axle shaft before it is removed from the axle assembly.
- Remove the tapered dowels and separate the axle shafts from the main axle hub assembly. **Figure 2.4.**

Figure 2.4

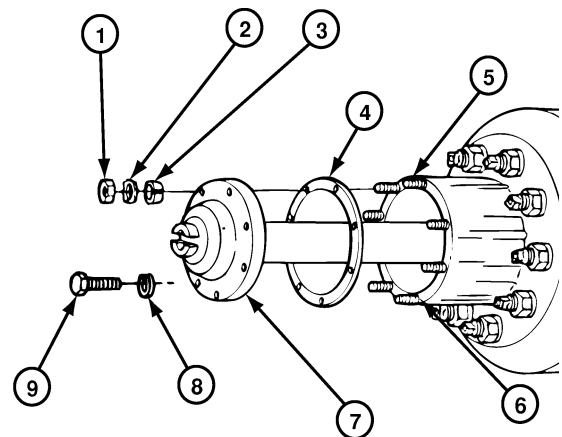

1002986a

- STUD NUT**
- WASHER**
- TAPERED DOWEL**
- GASKET**
- STUD**
- SHAFT HUB AXLE**
- AXLE SHAFT (FLANGE)**
- WASHER**
- CAPSCREW**

- Install a cover over the open end of each axle assembly hub where an axle shaft was removed.

Air Hammer Vibration Method

WARNING

Wear safe eye protection when using an air hammer. When using power tools, axle components can loosen and break off causing serious personal injury.

CAUTION

Do not use a chisel or wedge to loosen the axle shaft and tapered dowels. Using a chisel or wedge can result in damage to the axle shaft, the gasket and seal, and/or the axle hub.

- Use a round hammer bit and an air hammer such as Chicago Pneumatic CP-4181-Puler, or equivalent, to loosen tapered dowels and axle shaft.

Section 2 Disassembly

- Place the round hammer bit against the axle shaft (flange) between the hub studs. Operate the air hammer at alternate locations between the studs to loosen the tapered dowels and axle shaft from the hub. **Figure 2.5.**

Figure 2.5

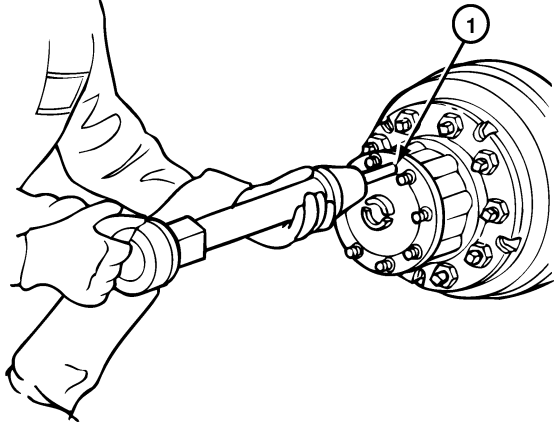

1002987a

- ROUND HAMMER BIT BETWEEN HUB STUDS

- Mark to identify each axle shaft before it is removed from the axle assembly.
- Remove the tapered dowels and separate the axle shaft from the main axle hub assembly. **Figure 2.4.**



CAUTION

Do not use a chisel or wedge to loosen the axle shaft and tapered dowels. Using a chisel or wedge can result in damage to the axle shaft, the gasket and seal, and/or the axle hub.

Carrier Removal from Axle

- Place a hydraulic roller jack under the differential carrier to support the assembly. **Figure 2.6.**
- Remove all but the top two carrier to housing capscrews or stud nuts and washers.
- Loosen the top two carrier-to-housing fasteners and leave attached to the assembly. The fasteners will hold the carrier in the housing.
- Loosen the differential carrier in the axle housing. Use a leather mallet to hit the mounting flange of carrier at several points.
- After the carrier is loosened, remove the top two fasteners.

Figure 2.6

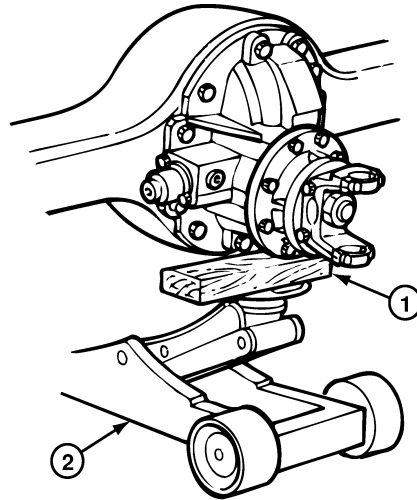

- WOOD BLOCK
- ROLLER JACK



CAUTION

When using a pry bar be careful not to damage the carrier or housing flange. Damage to these surfaces will cause oil leaks.

- Carefully remove the carrier from the axle housing using the hydraulic roller jack. Use a pry bar that has a round end to help remove the carrier from the housing.
- Lift the differential carrier by the input yoke or flange and place the assembly in a repair stand. **Figure 2.7.** Use a lifting tool for this procedure. Do not lift by hand. A carrier stand can be built by referring to **Figure 2.8.**

Figure 2.7

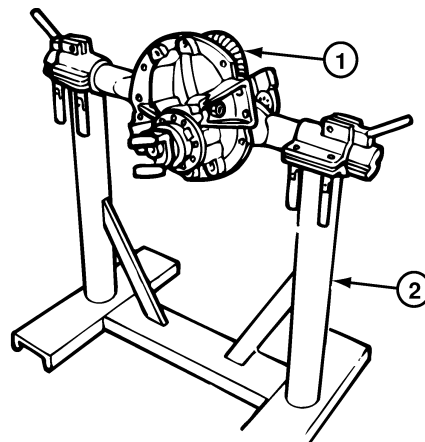

1002710a

- DIFFERENTIAL CARRIER
- REPAIR STAND

Section 2 Disassembly

A carrier stand, part number J 3409-D is available from Kent-Moore, Heavy-Duty Division, 28635 Mound Road, Warren, MI 48092.

Figure 2.8

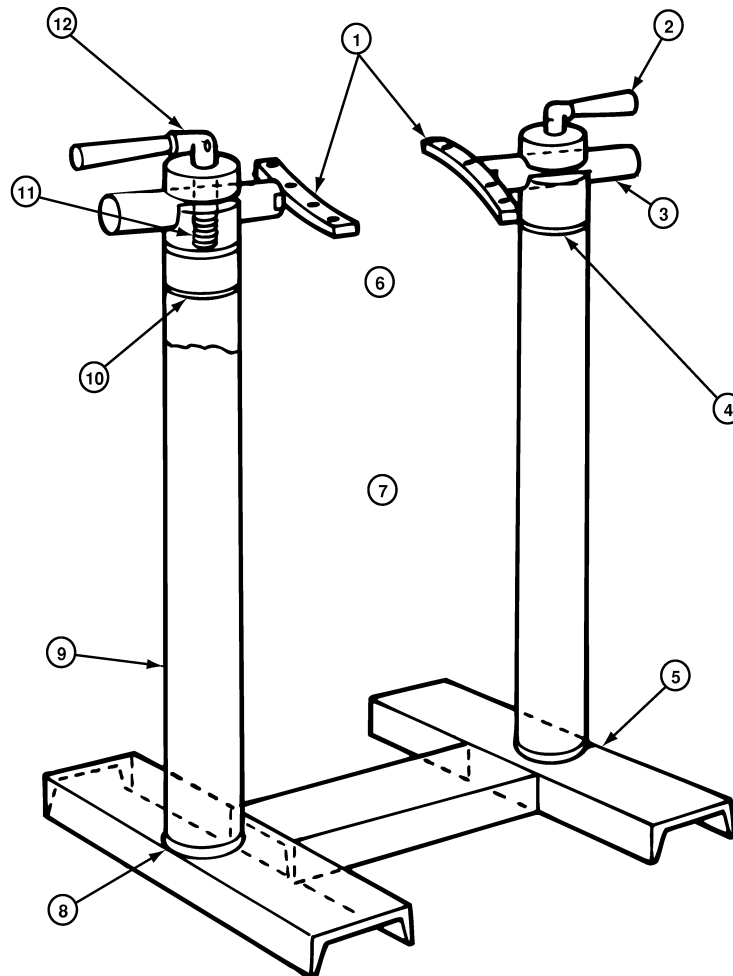

- 1 PLATES 8' LONG x 3/4" THICK x 1-1/4" WIDE WITH A TONGUE TO FIT SLOT IN BAR WELD PLATES TO BAR
- 2 HANDLE 7" LONG WITH SLOT IN ONE END TO FIT CLAMP SCREW
- 3 BAR 2" DIAMETER x 9" LONG WITH ONE END SLOTTED TO FIT PLATE
- 4 WELD ALL AROUND AFTER PRESSING PLUG IN PIPE
- 5 WELD
- 6 SHAPE AND SIZE OF HOLES TO FIT CARRIER
- 7 23-1/2" CENTER TO CENTER OF PIPE
- 8 CHAMFER END OF PIPE FOR WELDING
- 9 4" DIAMETER PIPE
- 10 PLUG 4" DIAMETER x 7" LONG WITH ONE END TURNED 3" LONG TO FIT PIPE. DRILL 2" HOLE AND MILL 3/16" WIDE SLOT 2" FROM TOP
- 11 SCREW 3-1/2" LONG x 5/8" DIAMETER WITH FLATS ON END TO FIT HANDLE AND 2-1/2" LENGTH OF THREAD ON OTHER END
- 12 DRILL 3/8" HOLE THROUGH HANDLE AND SCREW

CARRIER STAND

Section 2 Disassembly

Remove the Differential and Ring Gear from the Carrier

NOTE

Before working on the differential carrier, inspect the hypoid gear set for damage. If inspection shows no damage, the same gear set can be used again. Measure the backlash of the gear set and make a record of the dimension. Figure 2.9. (Refer to "Ring Gear Backlash Adjustment," steps 1-5 and Figure 5.59.) During differential reassembly, adjust the backlash to the original recorded dimension when the gear set is installed into the carrier.

Figure 2.9

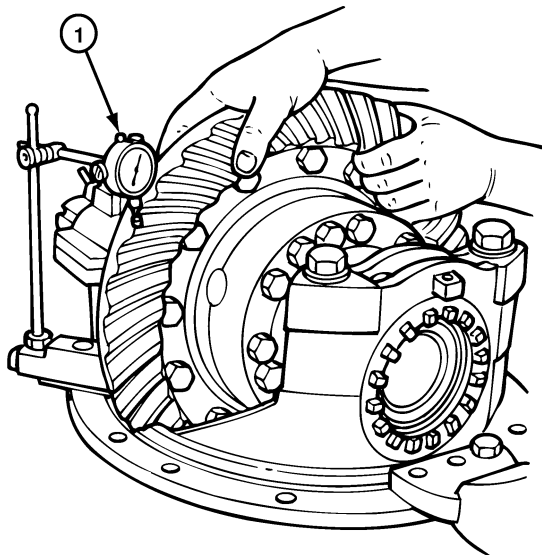

1002991a

1 DIAL INDICATOR

1. Loosen the jam nut* on the thrust screw*.
2. Remove the thrust screw* and jam nut* from the differential carrier. Figure 2.10 and Figure 2.11.

Figure 2.11

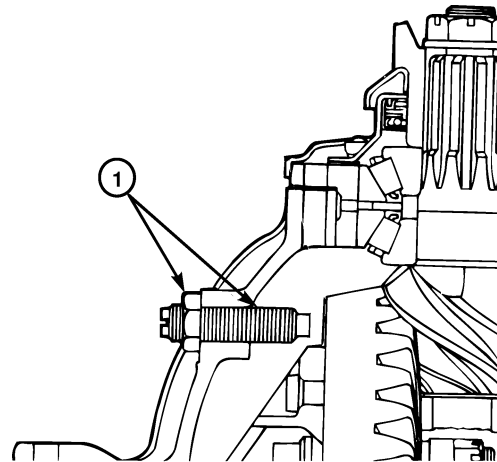

1002993a

1 THRUST SCREW AND JAM NUT

3. Rotate the differential carrier in the repair stand until the ring gear is at the top of the assembly.
4. Mark one carrier leg and bearing cap to correctly match the parts during carrier assembly. Mark the parts using a center punch and hammer. Figure 2.12.

Figure 2.12

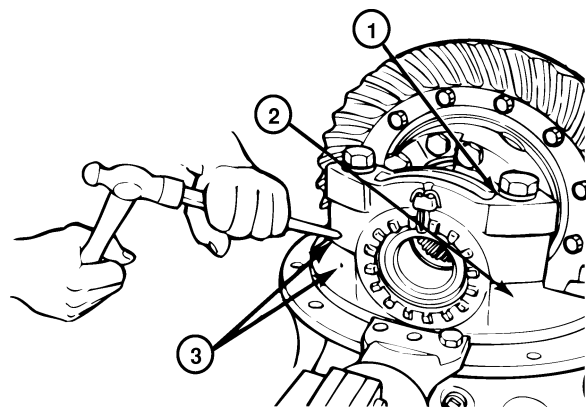

1002994a

- 1 BEARING CAP
- 2 CARRIER LEG
- 3 MATCH MARKS

Section 2 Disassembly

5. Remove the cotter keys*, pins* or lock plates* that hold the bearing adjusting rings in position. Use a small drift and hammer to remove pins. Each lock plate is held in position by two capscrews. **Figure 2.13.**
6. Remove the capscrews and washers that hold the two bearing caps on the carrier. Each cap is held in position by two capscrews and washers. **Figure 2.14.**
7. Remove the bearing caps and bearing adjusting rings from the carrier. **Figure 2.15.**
8. Safely lift the main differential and ring gear assembly from the carrier. Place the assembly on a work bench. **Figure 2.16.**

Figure 2.13

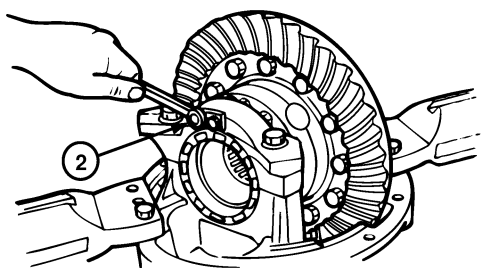
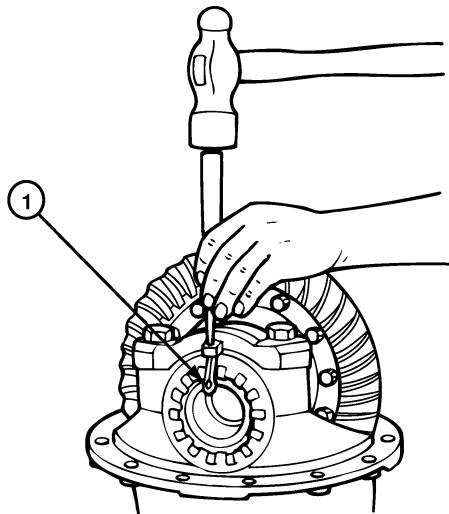

1002995a

- 1 REMOVING COTTER KEY
- 2 REMOVING LOCK PLATE

Figure 2.14

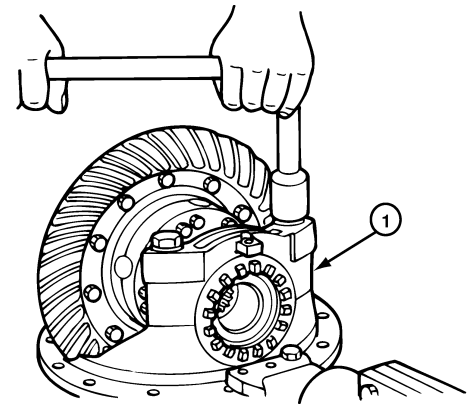

1002996a

- 1 BEARING CAP

Figure 2.15

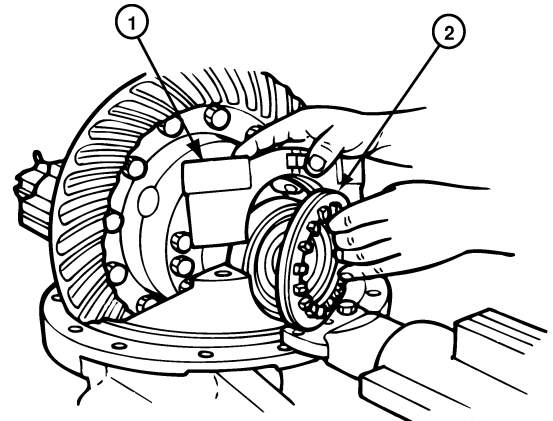

1002997a

- 1 BEARING CAP
- 2 BEARING ADJUSTING RING

Figure 2.16

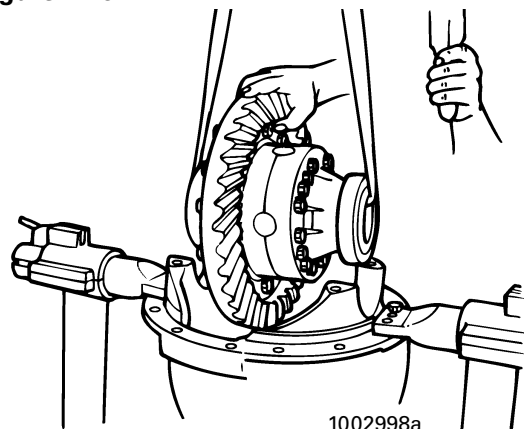

1002998a

Section 2 Disassembly

Disassemble the Differential and Ring Gear Assembly

1. If the matching marks on the case halves of the differential assembly are not visible, mark each case half with a center punch and hammer. The purpose of the marks is to match the plain half and flange half correctly when you assemble the carrier. **Figure 2.17.**

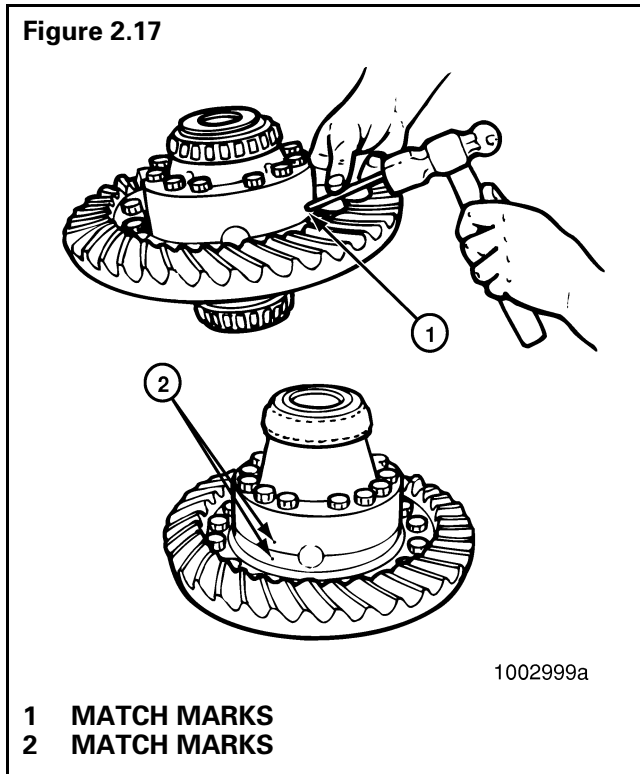

2. Remove the capscrews* and washers* or bolts*, nuts* and washers that hold the case halves together.

WARNING

Use a brass or leather mallet for assembly and disassembly procedures. Do not hit steel parts with a steel hammer. Pieces of a part can break off and cause serious personal injury.

3. Separate the case halves. If necessary, use a brass, plastic or leather mallet to loosen the parts.
4. Remove the differential spider (cross), four pinion gears, two side gears and six thrust washers from inside the case halves. **Figure 2.18.**
5. If the ring gear needs to be replaced, remove the bolts*, nuts*, and washers* that hold the gear to the flange case half.

Figure 2.18

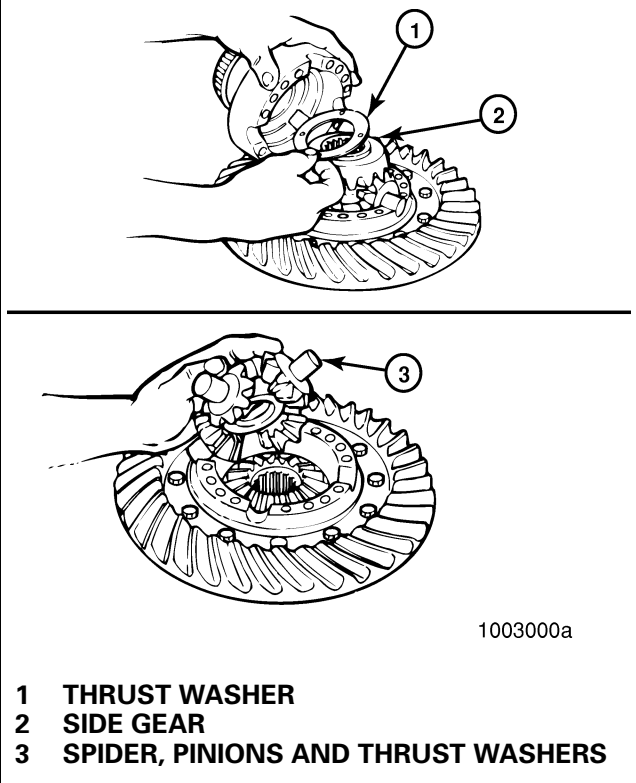

WARNING

Observe all warnings and cautions provided by the press manufacturer to avoid damage to components and serious personal injury.

CAUTION

Do not remove the rivets or rivet heads with a chisel and hammer. Using a flat edge tool can cause damage to the flange case. Refer to Figure 2.19.

6. If rivets* hold the ring gear to the flange case half, remove the rivets as follows:
 - a. Carefully center punch each rivet head in the center, on the ring gear side of the assembly.
 - b. Drill each rivet head on the ring gear side of the assembly to a depth equal to the thickness of one rivet head. Use a drill bit that is 1/32 of an inch smaller than the body diameter of the rivets. **Figure 2.19.**

Section 2 Disassembly

Figure 2.19

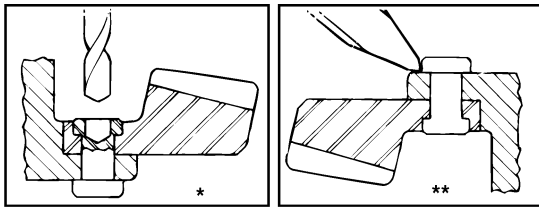

1003001a

- * **CORRECT DRILLING RIVETS FROM HEAD**
- ** **WRONG CHISELING RIVETS FROM HEAD**

- c. Press the rivets through holes in the ring gear and flange case half. Press from the drilled rivet head.



WARNING

Observe all warnings and cautions provided by the press manufacturer to avoid damage to components and serious personal injury.

7. Separate the case half and ring gear using a press. Support the assembly under the ring gear with metal or wood blocks and press the case half through the gear. **Figure 2.20.**

Figure 2.20

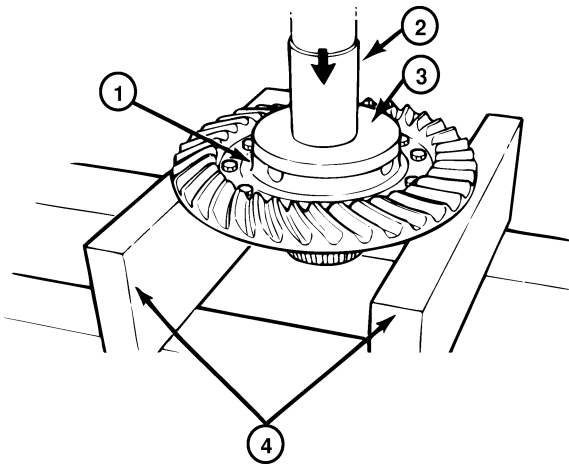

1003002a

- 1 **CASE HALF**
- 2 **PRESS**
- 3 **PLATE**
- 4 **SUPPORTS**

8. If the differential bearings need to be replaced, remove the bearing cones from the case halves. Use a bearing puller or press. **Figure 2.21.**

Figure 2.21

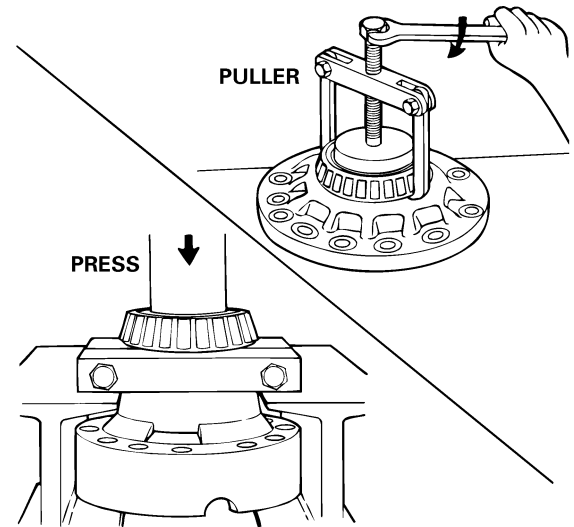

1002750a

- * **PULLER**
- ** **PRESS**

Section 2 Disassembly

Remove the Drive Pinion and Bearing Cage from Carrier

1. Fasten a flange bar to the input yoke or flange. When the nut is removed, the bar will hold the drive pinion in position. **Figure 2.22.**

Figure 2.22

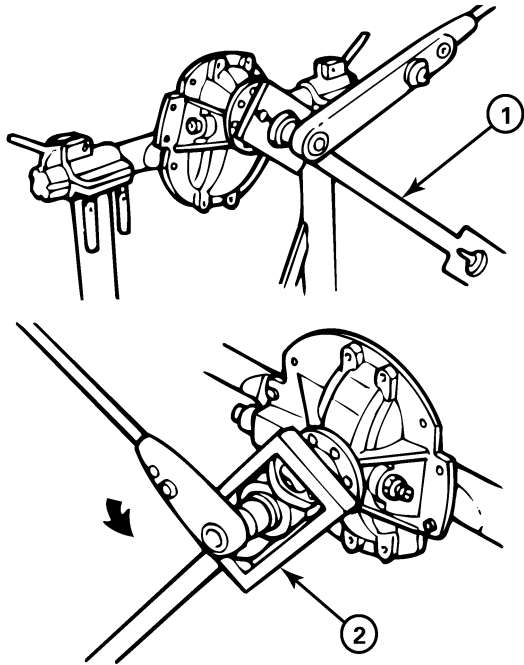

1003347a

- 1 FLANGE BAR
- 2 YOKE BAR

2. Remove the nut and washer* from the drive pinion. **Figure 2.22.**
3. Remove the yoke or flange bar.

CAUTION

Do not use a hammer or mallet to loosen and remove the yoke or flange. A hammer or mallet can damage the parts and cause driveline runout, or driveline imbalance problems after carrier to driveline assembly.

4. Remove the yoke or flange from the drive pinion. If the yoke or flange is tight on the pinion, use a puller for removal. **Figure 2.23.**
5. Remove the capscrews and washers that hold the bearing cage in the carrier. **Figure 2.24.**

Figure 2.23

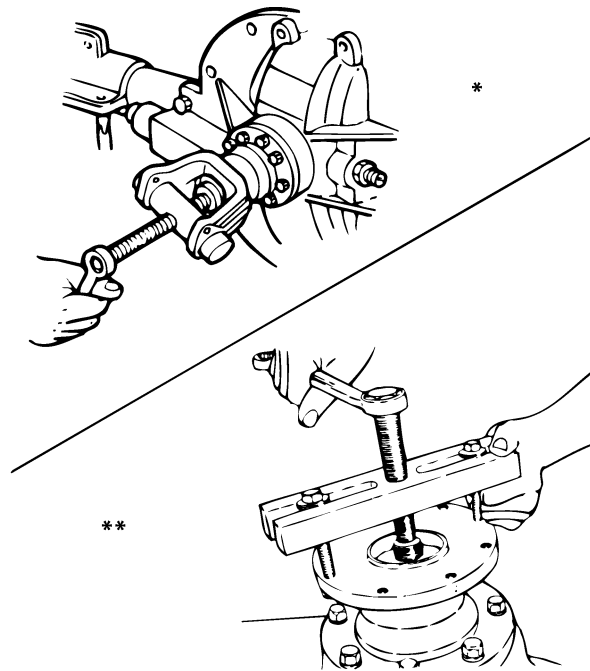

1003348a

- * YOKE PULLER
- ** FLANGE PULLER

Figure 2.24

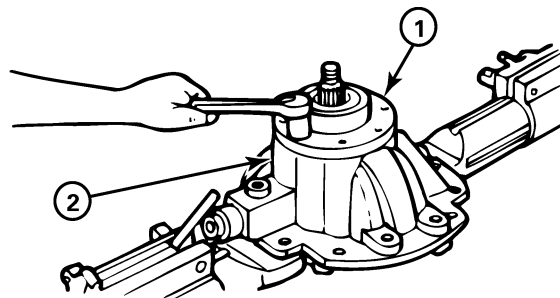

1003350a

- 1 BEARING CAGE
- 2 CARRIER

! WARNING

Use a brass or leather mallet for assembly and disassembly procedures. Do not hit steel parts with a steel hammer. Pieces of a part can break off and cause serious personal injury.

! CAUTION

Do not use a pry bar to remove the bearing cage from the carrier. A pry bar can damage the bearing case, shims and carrier.

- Remove the drive pinion, bearing cage and shims from the carrier. If the bearing cage is tight in the carrier, hit the bearing cage at several points around the flange area with a leather, plastic or rubber mallet. **Figure 2.25.**

Figure 2.25

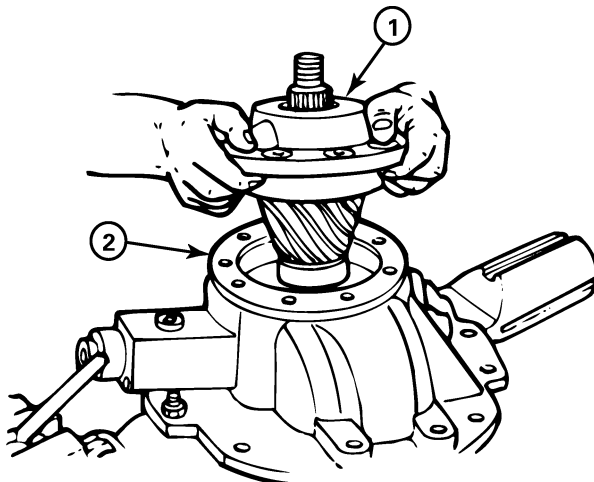

1003349a

- DRIVE PINION AND BEARING CAGE
- SHIMS

- If the shims are in good condition, keep the shims together for use later when the carrier is assembled.
- If shims are to be discarded because of damage, first measure the total thickness of the pack. Make a note of the dimension. The dimension will be needed to calculate the depth of the drive pinion in the carrier when the gear set is installed.

Disassemble the Drive Pinion and Bearing Cage

Figure 2.26

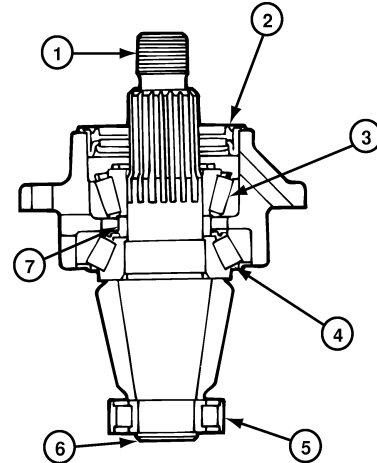

- DRIVE PINION
- OIL SEAL
- OUTER BEARING (CUP AND CONE)
- INNER BEARING (CUP AND CONE)
- SPIGOT BEARING
- SNAP RING
- BEARING SPACER

! WARNING

Observe all warnings and cautions provided by the press manufacturer to avoid damage to components and serious personal injury.

- Place the drive pinion and bearing cage in a press. The pinion shaft must be toward the top of the assembly. **Figure 2.27.**

Figure 2.27

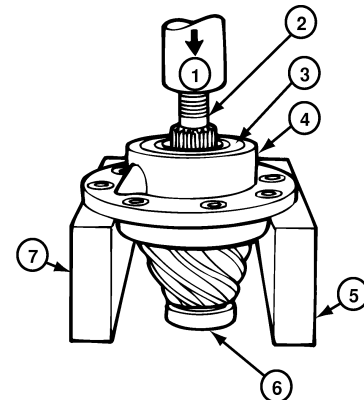

- PRESS
- DRIVE PINION
- OIL SEAL
- BEARING CAGE
- SUPPORT
- SPIGOT BEARING
- SUPPORT

Section 2 Disassembly

2. Support the bearing cage under the flange area with metal or wood blocks. **Figure 2.27.**
3. Press the drive pinion through the bearing cage. **Figure 2.27.**

WARNING

Use a brass or leather mallet for assembly and disassembly procedures. Do not hit steel parts with a steel hammer. Pieces of a part can break off and cause serious personal injury.

NOTE

The inner bearing cone and bearing spacer will remain on the pinion shaft.

4. If a press is not available, use a leather, plastic or rubber mallet to drive the pinion through the bearing cage.

CAUTION

Be careful when removing the seal. Do not damage the wall of bore. Damage to the bore wall can result in oil leaks.

NOTE

When the oil seal has been removed, always replace it with a new seal during component reassembly.

5. Use a press and a sleeve to remove the triple-lip or unitized oil seal from the bearing cage. If a press is not available, place a tool with a flat blade under the flange to remove the oil seal from the cage. **Figure 2.28.**

Figure 2.28

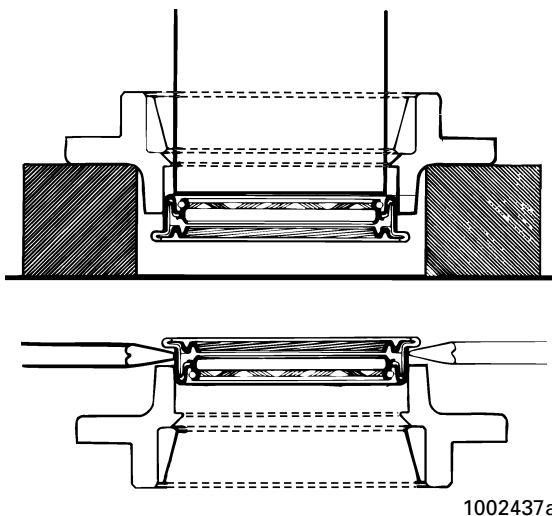

WARNING

Observe all warnings and cautions provided by the press manufacturer to avoid damage to components and serious personal injury.

6. If the pinion bearings need to be replaced, remove the inner and outer bearing cups from the inside of cage. Use a press and sleeve, bearing puller or a small drift hammer. The type of tool used depends on the design of the bearing cage. **Figure 2.29.**

When a press is used, support the bearing cage under the flange area with metal or wood blocks.

Figure 2.29

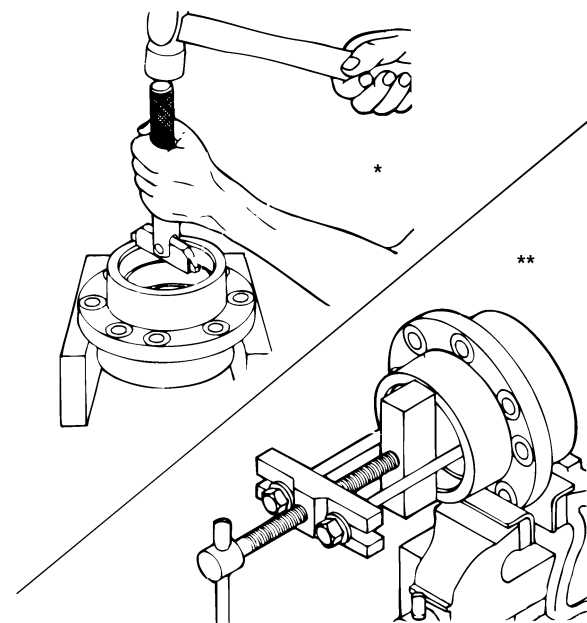

* BEARING DRIVER
** BEARING PULLER

Section 2 Disassembly

7. If the pinion bearings need to be replaced, remove the inner bearing cone from the drive pinion with a press or bearing puller. The puller **must** fit under the inner race of the cone to remove the cone correctly without damage. **Figure 2.30.**

Figure 2.30

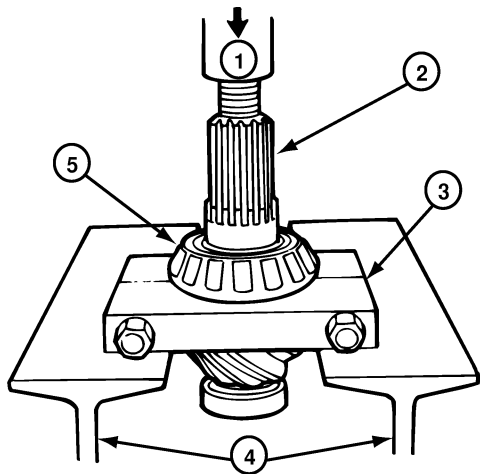

1003012a

- 1 PRESS
- 2 DRIVE PINION
- 3 BEARING PULLER
- 4 SUPPORTS
- 5 INNER BEARING CONE

8. If the spigot bearing needs to be replaced, place the drive pinion in a vise. Install a soft metal cover over each vise jaw to protect the drive pinion.
9. Remove the snap ring* from the end of drive pinion with snap ring pliers that expand. **Figure 2.31.**

NOTE

Some spigot bearings are fastened to the drive pinion with a special peening tool. Figure 2.32.

Figure 2.31

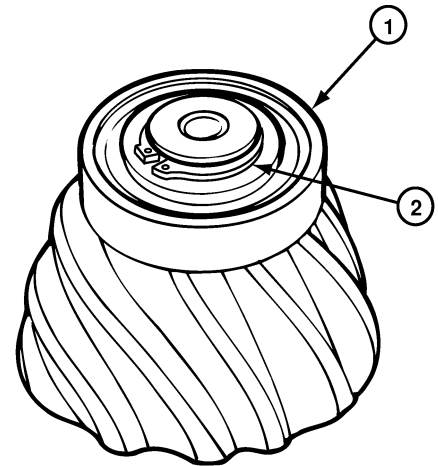

1003013a

- 1 SPIGOT BEARING
- 2 SNAP RING

Figure 2.32

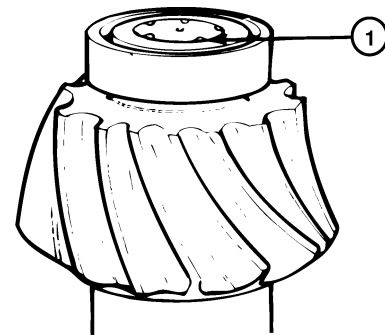

1003014a

- 1 PEENING POINTS

Section 2 Disassembly

10. Remove the spigot bearing from the drive pinion with a bearing puller. **Figure 2.33.**

NOTE

*Some spigot bearings are a two-piece assembly. Remove the inner race from the pinion with a bearing puller. Remove the outer race/roller assembly from carrier with a drift or a press. **Figure 2.34.***

Figure 2.33

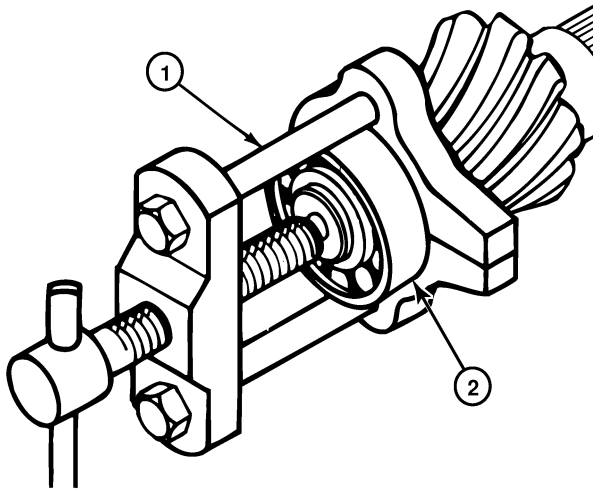

1003015a

- 1 BEARING PULLER
- 2 SPIGOT BEARING

Figure 2.34

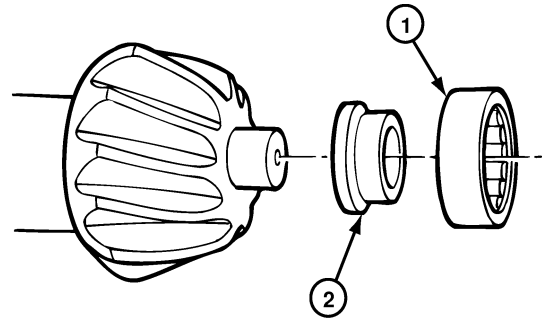

1003016a

- 1 REMOVE OUTER RACE AND ROLLER ASSEMBLY FROM CARRIER
- 2 REMOVE INNER RACE FROM PINION

Section 3

Preparing the Parts for Assembly

Clean and Inspect Yokes

WARNINGS

⚠ To prevent serious eye injury, always wear safe eye protection when you perform vehicle maintenance or service.

⚠ Solvent cleaners can be flammable, poisonous and cause burns. Examples of solvent cleaners are carbon tetrachloride, emulsion-type cleaners and petroleum-based cleaners. To avoid serious personal injury when you use solvent cleaners, you must carefully follow the manufacturer's product instructions and these procedures:

- Wear safe eye protection.
 - Wear clothing that protects your skin.
 - Work in a well-ventilated area.
 - Do not use gasoline, or solvents that contain gasoline. Gasoline can explode.
 - You must use hot solution tanks or alkaline solutions correctly. Follow the manufacturer's instructions carefully.
1. Clean the ground and polished surface of the yoke journal using a clean shop towel and a safe cleaning solvent. Do not use abrasive cleaners, towels, or scrubbers to clean yoke or flange surface. DO NOT USE GASOLINE.
 2. Inspect the original yoke seal surface for any grooves.
 - a. The rubber inner sleeve of the unitized pinion seal (UPS) allows the reuse of yokes with grooves unless the groove depths are excessively deep. If grooves are present, measure the groove diameters with calipers. Refer to **Figure 3.1** to determine if the yoke is usable.
 - b. If grooves are present on yoke hubs which are used with single or triple lip seals, then the yokes must be replaced.
 3. If any of the yoke grooves measure less than the dimensions in **Figure 3.1**, replace the yoke. The rubber inner sleeve of the unitized pinion seal (UPS) is designed to seal on the yoke and rotate with the yoke.

Figure 3.1

YOKE SEAL DIAMETER	MINIMUM YOKE DIAMETER AT GROOVE (INCHES)
3.000/3.005"	2.990"
3.250/3.255"	3.240"

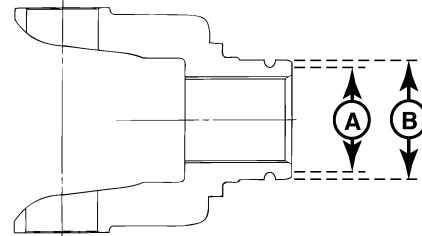

A MINIMUM GROOVE DEPTH — DIAMETER
B YOKE SEAL DIAMETER

UNITIZED PINION SEAL (UPS)

⚠ CAUTION

Do not install a press on shaft excluder (or POSE™ seal) after installation of a unitized pinion seal. The use of a POSE™ seal will prevent correct seating of the unitized pinion seal on the yoke and will result in lubricant leakage at the seal. POSE™ seal installation is recommended only for triple lip and other previous design seals.

Do not use thin metal wear sleeves to refresh the yoke surface. Wear sleeves pressed onto the yoke will prevent correct seating of the pinion seal and damage the pinion seal assembly. Wear sleeve usage will cause the seal to leak.

Section 3

Preparing the Parts for Assembly

Cleaning Ground and Polished Parts



WARNING

To prevent serious eye injury, always wear safe eye protection when you perform vehicle maintenance or service.

1. Use a cleaning solvent to clean ground or polished parts or surfaces. Kerosene or diesel fuel oil can be used for this purpose. **Do not use gasoline.**



WARNING

Solvent cleaners can be flammable, poisonous and cause burns. Examples of solvent cleaners are carbon tetrachloride, emulsion-type cleaners and petroleum-based cleaners. To avoid serious personal injury when you use solvent cleaners, you must carefully follow the manufacturer's product instructions and these procedures:

- *Wear safe eye protection.*
 - *Wear clothing that protects you skin.*
 - *Work in a well-ventilated area.*
 - *Do not use gasoline, or solvents that contain gasoline. Gasoline can explode.*
 - *You must use hot solution tanks or alkaline solutions correctly. Follow the manufacturer's instructions carefully.*
2. Use a tool with a flat blade if required, to remove sealant material from parts. Be careful not to damage the polished or smooth surfaces.



CAUTION

Do not use hot solution tanks or water and alkaline solutions to clean ground or polished parts. Damage to parts will result.

3. **Do not** clean ground or polished parts with water or steam. Do not immerse ground or polished parts in a hot solution tank or use strong alkaline solutions for cleaning, or the smooth sealing surface may be damaged.

Cleaning Rough Parts

1. Clean rough parts with the same method as cleaning ground and polished parts.
2. Rough parts can be cleaned in hot solution tanks with a weak or diluted alkaline solution.
3. Parts must remain in hot solution tanks until heated and completely cleaned.



WARNING

Solvent cleaners can be flammable, poisonous and cause burns. Examples of solvent cleaners are carbon tetrachloride, emulsion-type cleaners and petroleum-based cleaners. To avoid serious personal injury when you use solvent cleaners, you must carefully follow the manufacturer's product instructions and these procedures:

- *Wear safe eye protection.*
 - *Wear clothing that protects you skin.*
 - *Work in a well-ventilated area.*
 - *Do not use gasoline, or solvents that contain gasoline. Gasoline can explode.*
 - *You must use hot solution tanks or alkaline solutions correctly. Follow the manufacturer's instructions carefully.*
4. Parts must be washed with water until all traces of the alkaline solution are removed.

Cleaning Axle Assemblies

1. A complete axle assembly can be steam cleaned on the outside to remove dirt.
2. Before the axle is steam cleaned, close or place a cover over all openings in the axle assembly. Examples of openings are breathers or vents in air chambers.

Drying Parts After Cleaning

1. Parts must be dried immediately after cleaning and washing.
2. Dry the parts using soft, clean paper or cloth rags.



CAUTION

Damage to bearings can result when they are rotated and dried with compressed air.

3. Except for bearings, parts can be dried with compressed air.

Section 3

Preparing the Parts for Assembly

Preventing Corrosion on Cleaned Parts

1. Apply axle lubricant to cleaned and dried parts that are not damaged and are to be assembled.
2. To store parts, apply a special material that prevents corrosion to all surfaces. Wrap cleaned parts in a special paper that will protect the parts from moisture and prevent corrosion.

Inspecting Parts

It is very important to inspect all parts carefully and completely before the axle or carrier is assembled. Check all parts for wear and replace damaged parts. Replacement of damaged or worn parts now, will prevent failure of the assembly later.

1. Inspecting Tapered Roller Bearings:

Inspect the cup, cone, rollers and cage of all tapered roller bearings in the assembly. If any of the following conditions exist, the bearing **must** be replaced.

- a. The center of large-diameter end of rollers worn level with or below the outer surface. **Figure 3.2.**
- b. The radius at large-diameter end of rollers worn to a sharp edge. **Figure 3.2.**

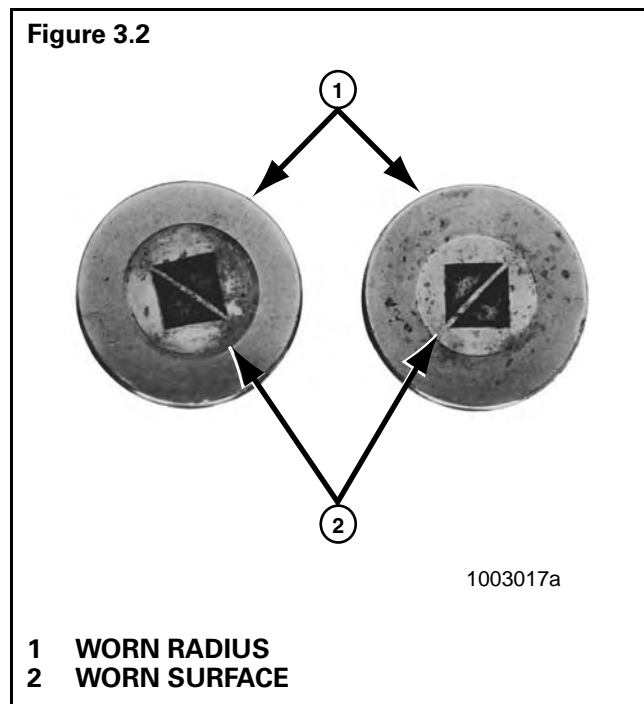

- c. A visible roller groove in the cup or cone inner race surfaces. The groove can be seen at the small- or large-diameter end of both parts. **Figure 3.3.**
- d. Deep cracks or breaks in the cup, cone inner race or roller surfaces. **Figure 3.3.**
- e. Bright wear marks on the outer surface of the roller cage. **Figure 3.4.**

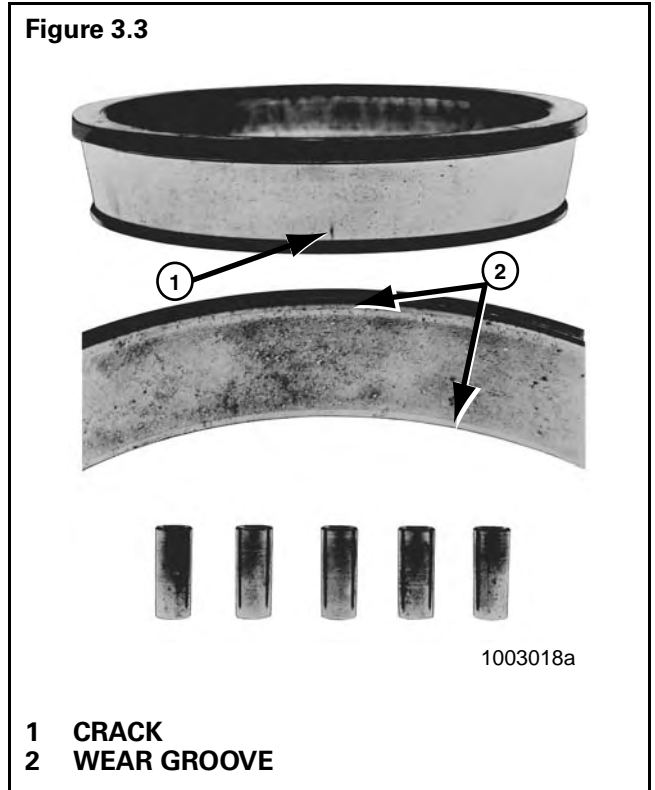

Section 3 Preparing the Parts for Assembly

- f. Damage on rollers and on surfaces of the cup and cone inner race that touch the rollers. **Figure 3.5.**
- g. Damage on the cup and cone inner race surfaces that touch the rollers. **Figure 3.6.**

Figure 3.5

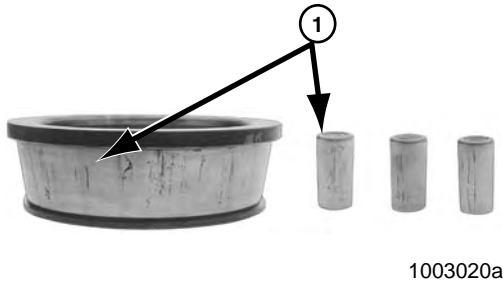

1003020a

1 ETCHING AND PITTING

Figure 3.6

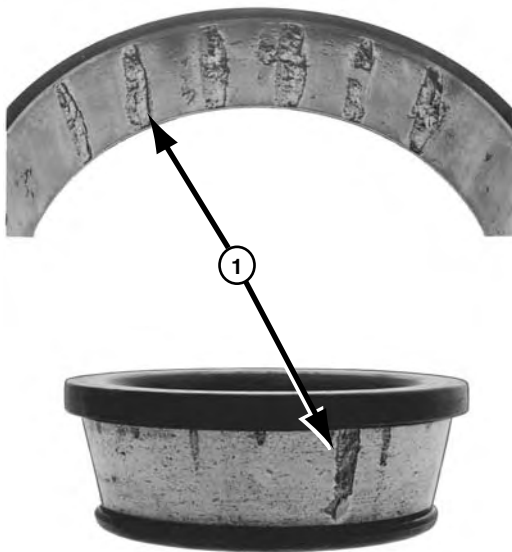

1003021a

1 SPALLING AND FLAKING

CAUTION

Hypoid drive pinions and ring gears are machined in matched sets. When a drive pinion or ring gear of a hypoid set needs to be replaced, both drive gear and pinion must be replaced at the same time.

- 2. Inspect hypoid pinions and gears for wear or damage. Gears that are worn or damaged **must** be replaced.

CAUTION

Always replace thrust washers, differential side gears and pinion gears in full matched sets. A higher stress on original parts and early failure of the entire assembly will result if a new part is used in combination with parts that are older or worn.

- 3. Inspect the Main Differential Assembly:
Inspect the following parts for wear or stress. Parts that are damaged **must** be replaced. **Figure 3.7.**

Figure 3.7

DIFFERENTIAL CASE HALVES

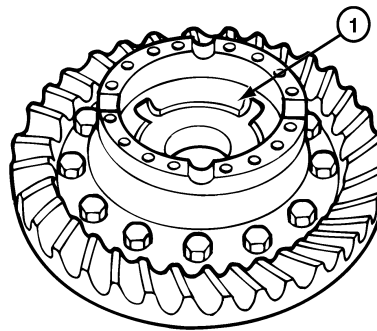

DIFFERENTIAL GEAR NEST ASSEMBLY

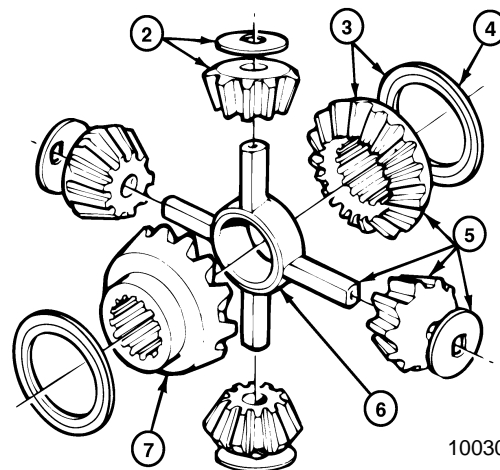

1003022a

- 1 INSPECT INSIDE SURFACES
- 2 PINION AND THRUST WASHER
- 3 SIDE GEAR AND THRUST WASHER
- 4 INSPECT
- 5 INSPECT
- 6 SPIDER (CROSS)
- 7 INSPECT
- * DIFFERENTIAL CASE HALVES
- ** DIFFERENTIAL GEAR NEST ASSEMBLY

Section 3

Preparing the Parts for Assembly

- a. Inside surfaces of both case halves.
 - b. Both surfaces of all thrust washers.
 - c. The four trunnion ends of the spider (cross).
 - d. Teeth and splines of both differential side gears.
 - e. Teeth and bore of all differential pinions.
4. Inspect Axle Shafts:
- a. Inspect axle shafts for wear and cracks at the flange, shaft and splines.
 - b. Replace axle shafts, if required.

Repair or Replacement of Parts, General

Replace worn or damaged parts of an axle assembly. The following are some examples in checking for part replacement or repair.

1. Replace any fastener if corners of the head are worn.
2. Replace washers if damaged.
3. Replace gaskets, oil seals or grease seals at the time of axle or carrier repair.
4. Clean parts and apply new silicone gasket material where required when axle or carrier is assembled. **Figure 3.8.**

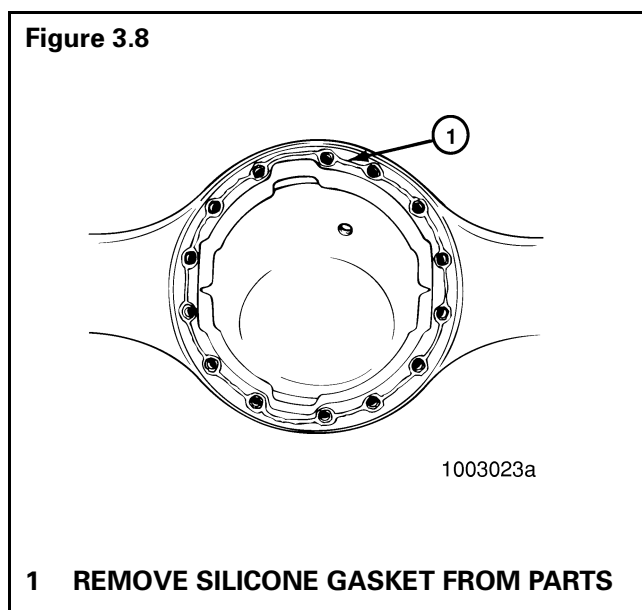

5. Remove nicks, mars and burrs from parts with machined or ground surfaces. Use a fine file, india stone, emery cloth or crocus cloth for this purpose.

CAUTION

Threads must be without damage and clean so that accurate adjustments and correct torque values can be applied to fasteners and parts.

6. Clean and repair threads of fasteners and holes. Use a die or tap of the correct size or a fine file for this purpose.

WARNING

Repair of axle housings by bending or straightening will cause poor or unsafe vehicle operation and early failure of the axle.

Repair Axle by Welding

1. RICO will permit repairing drive axle housing assemblies by welding **only** in the following areas:
 - a. Only RT-46-160 axles housing to cover weld joints. Refer to TP-9599.
 - b. Snorkel welds.
 - c. Housing seam welds between the suspension attaching brackets.
 - d. Bracket welding to drive axle housing. Refer to TP-9421.
 - e. Refer to RICO Maintenance Manual 8 for approved axle welding procedures.

WARNINGS

⚠ *Using wrong welding procedures or welding at locations other than the three areas permitted by RICO will make the heat-treated component weak. A weak component will cause poor or unsafe operation of the vehicle and early axle failure. The following procedure must be used.*

⚠ *Solvent cleaners can be flammable, poisonous and cause burns. Examples of solvent cleaners are carbon tetrachloride, emulsion-type cleaners and petroleum-based cleaners. To avoid serious personal injury when you use solvent cleaners, you must carefully follow the manufacturer's product instructions and these procedures:*

- *Wear safe eye protection.*
- *Wear clothing that protects you skin.*
- *Work in a well-ventilated area.*
- *Do not use gasoline, or solvents that contain gasoline. Gasoline can explode.*
- *You must use hot solution tanks or alkaline solutions correctly. Follow the manufacturer's instructions carefully.*

Section 3

Preparing the Parts for Assembly

CAUTION

Welding can be used when the crack or damaged area is within the old weld material. Replace the axle housing if the crack extends into the metal next to the old weld. A repaired housing must be used in correct applications.

2. Welding Procedure
 - a. Drain the lubricant from the axle assembly.
 - b. Remove the axle shafts and differential carrier from the axle housing.
 - c. Remove hub, drum, wheel bearing and brake air chambers.
 - d. Clean the damaged area inside and outside the housing. Cleaning solvent can be used.
 - e. Grind the damaged weld to the base metal.
 - f. Warm the complete axle housing to a temperature of 70°F-80°F (21°C-27°C) or higher.
 - g. Before you start welding, heat the damaged area to be repaired to approximately 300°F (149°C).
 - h. Use a 70,000 psi tensile weld material and the correct voltage and amperage for the diameter weld rod used. Examples of weld rods that can be used are E-7018 or ER-70S-3.
 - i. Fill in the weld gap as follows:

CAUTIONS

 *If the E-7018 weld rod is used, the rod must be kept dry. Electrodes that are not stored in the correct sealed containers must be heated at 700°F (371°C) for one hour before welding. Wet electrodes must be dried at 180°F (82°C) for one to two hours and then heated at 700°F (371°C) for one hour before welding.*

 *Do not connect the ground cable at any point on the axle assembly that will place a bearing between the ground cable and weld area. If a bearing is between the ground cable and weld, the bearing will be damaged because of electricity arcing.*

 *A good location to connect the ground cable is the spring mounting pad of the housing.*

1. The opening in cover welds **must** be filled level with the old weld.

2. The opening in seam welds **must** be ground out to 70% of the wall thickness. The wall thickness can be measured at the carrier opening of housing.
3. Clean the new weld area. Carefully remove all the rough weld material.
4. Install the differential carrier and axle shafts.
5. Fill the axle assembly with the correct amount of lubricant. Refer to Maintenance Manual 1, *Lubrication*, for information on lubricants.

NOTE

Before welding brackets or other components to the axle housing, contact RICO for proper welding procedures.

Bending or Straightening Drive Axle Housings

RICO is emphatically opposed to any attempt to correct or modify drive axle housings by bending or straightening. All damaged drive axle housings should be replaced.

WARNING

Do not bend or straighten damaged drive axle housings. Any bending or straightening process may result in misalignment or weakening of the axle housing and result in component damage or serious personal injury.

Removing Dri-Loc® Fasteners

If it is difficult to remove fasteners from components, the strength of Dri-Loc®, RICO adhesive or Loctite® 277 can be decreased by heating. Use the following procedure:

1. Heat the fastener for three to five seconds **only** and try to loosen the fastener with a wrench. **Do not** use an impact wrench to loosen the fastener or hit the fastener with a hammer.

CAUTION

Do not exceed 350°F (177°C) maximum. Heating must be done slowly to prevent thermal stresses in the other components.

2. Repeat step 1 until the fastener can be removed.

Section 4 General Information

Installing Fasteners with Pre-applied Adhesive, RICO Liquid Adhesive 2297-C-7049, Loctite® 680 Liquid Adhesive or Equivalent

Installing New Fasteners with Pre-applied Adhesive Patches



WARNING

To prevent serious eye injury, always wear safe eye protection when you perform vehicle maintenance or service.

1. Clean the oil and dirt from threaded holes. Use a wire brush. There is no other special cleaning required.



CAUTION

Do not apply adhesives or sealants on new fasteners with pre-applied adhesive patches or inside closed threaded holes. If other adhesives or sealants are used, the new adhesive will not function correctly.

2. Assemble parts using the new pre-applied adhesive fasteners.

NOTE

There is no drying time required for fasteners with pre-applied adhesive.

3. Tighten the fasteners to the required torque value for that size fastener.

Installing Original or Used Fasteners Using RICO Liquid Adhesive 2297-C-7049 or Loctite® 680 or Equivalent

1. Clean the oil, dirt and old adhesive from all threads and threaded holes. Use a wire brush.
2. Apply four or five drops of RICO Liquid Adhesive, Loctite® 680 or equivalent inside each threaded hole or bore ONLY. Make sure the adhesive is applied inside to the bore threads. **Figure 4.1.**

Figure 4.1

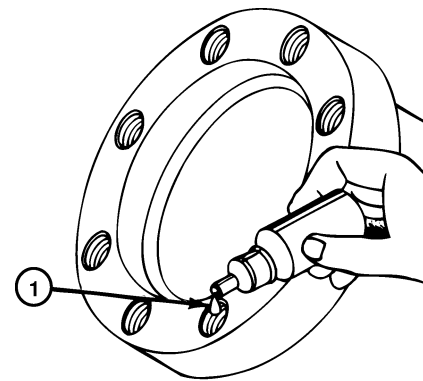

1003025a

1 4 TO 5 DROPS ON BORE THREADS



CAUTION

Do not apply adhesive directly to the fastener threads. Air pressure in a closed hole will push the adhesive out and away from mating surfaces as the fastener is installed.

3. Tighten the fasteners to the required torque value for that size fastener.

NOTE

There is no drying time required for RICO Liquid Adhesive 2297-C-7049, Loctite® 680 or equivalent.

Section 4 General Information

Application of RICO Adhesive 2297-T-4180 in Bearing Bores for the Differential

Use adhesive 2297-T-4180 for all axles.

1. Clean the oil and dirt from outer diameters of bearing cups and bearing bores in the carrier and bearing caps. There is no special cleaning required.
2. Apply axle lubricant to the bearing cones and the inner diameters of the bearing cups of the main differential. **Do not** get oil on the outer diameter of the bearing cup and **Do not** permit oil to drip on the bearing bores.
3. Apply a single continuous bead of the adhesive to the bearing bores in the carrier and bearing caps. Apply the adhesive 360° around the smooth, ground surfaces only. **Do not** place adhesive on threaded areas. **Figure 4.2.**

Figure 4.2

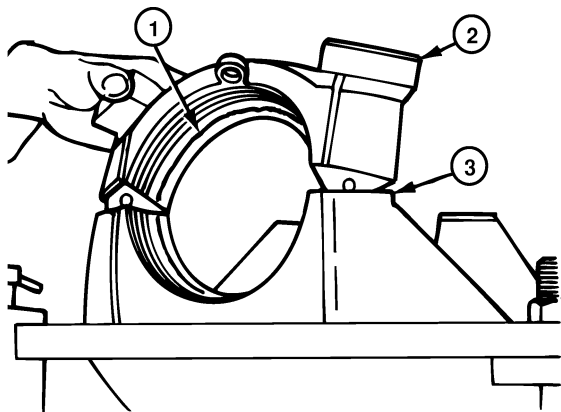

- 1 ADHESIVE
- 2 BEARING CAP
- 3 CARRIER LEG

NOTE

RICO adhesive 2297-T-4180 will become hard (dry) in approximately two hours. The following two steps of the procedure must be done in two hours from the time the adhesive was applied. If two hours have passed since application, clean the adhesive from the parts again and apply new adhesive.

4. Install the main differential assembly, bearing cups and bearing caps into the carrier. Use the normal procedure, refer to "Install the Differential and Ring Gear Assembly" and **Figure 5.47** through **Figure 5.50.**

5. Adjust preload of the differential bearings, backlash and tooth contact patterns of the gear set as required using the normal procedures. Refer to "Adjust Preload of Differential Bearings" through "Install Differential Carrier into Axle Housing."

Application of Three Bond 1216 or Equivalent Silicone Gasket Material

WARNING

When you apply some silicone gasket materials, small amounts of acid vapor are present. To prevent possible serious injury, the work area must be well ventilated. If the silicone gasket material gets into your eyes, flush them with water for 15 minutes. Have your eyes checked by a doctor as soon as possible.

NOTE

The following silicone gasket products or equivalent can be used for RICO components:

- **Three Bond Liquid Gasket No. TB 1216 (Grey)**
- **Loctite® Ultra Grey Adhesive/Sealant #18581**
- **From RICO: Ten-ounce tubes, Part No. 2297-F-7052**

1. Remove all old gasket material from both surfaces. **Figure 4.3.**
2. Clean the surfaces where silicone gasket material will be applied. Remove all oil, grease, dirt and moisture without damaging the mating surfaces. **Figure 4.3.**
3. Dry both surfaces.

Figure 4.3

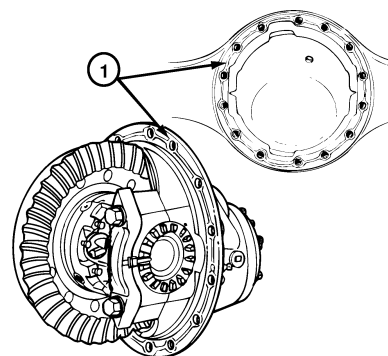

- 1 REMOVE OLD SEALANT MATERIAL
- HOUSING AND CARRIER SHOWN**

Section 4 General Information

CAUTION

The amount of silicone gasket material applied must not exceed 0.125 inch (3 mm) diameter bead. Too much gasket material can block lubrication passages and result in damage to the components.

4. Apply 0.125 inch (3 mm) diameter continuous bead of the silicone gasket material around one surface. Also apply the gasket material around the edge of all fastener holes on that surface. **Figure 4.4.**
5. Assemble the components immediately to permit the silicone gasket material to compress evenly between the parts. Tighten fasteners to the required torque value for that size fastener. There is no special procedure or additional torque value required. Refer to **Table J.**
6. Wait 20 minutes before filling the assembly with lubricant.

Figure 4.4

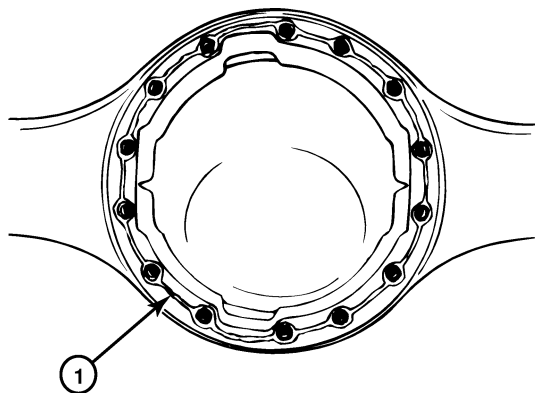

1003028a

- 1 0.125" (3 MM) DIAMETER SILICONE GASKET BEAD

Installing Tight Fit Yokes and POSE™ Seal

Figure 4.5

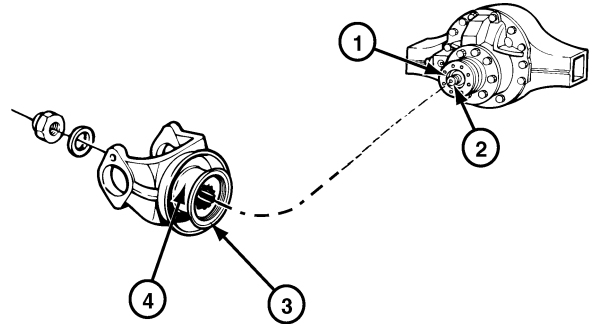

1003360a

- 1 LUBRICATE TRIPLE-LIP (MAIN) SEAL
- 2 INPUT SHAFT (PINION)
- 3 POSE™ SEAL (0.25"–0.50" ONTO HUB)
- 4 INSPECT YOKE HUB

1. Apply the same lubricant used in the axle housing to the hub of the yoke or flange.
2. Inspect and make sure the lips of the POSE™ seal and the outer retainer of the triple-lip seal (main seal) are clean and free from dirt and particles that may cause lubricant leakage between the seals.

Section 4 General Information

3. Install the POSE™ seal on the hub of the yoke or flange by hand. The lips of the seal must face toward the end of the hub (opposite shoulder). Slide the POSE™ seal on the hub until the lips are from 0.25 inch to 0.50 inch (6.4 mm–12.7 mm) from the end of the hub. **Do not install the POSE™ seal against the shoulder.** Figure 4.6.

NOTE

The POSE™ seal will position itself correctly as the yoke or flange is pressed on the shaft.

4. Before you install the yoke or flange on the shaft, again apply the same lubricant used in the axle housing to the hub.

Figure 4.6

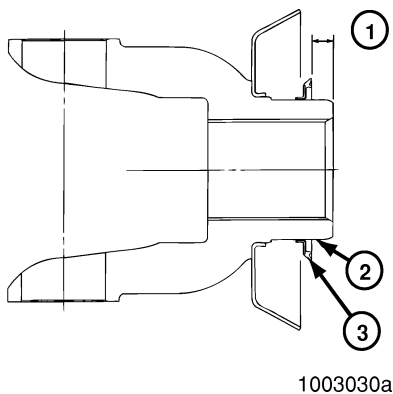

- 1 0.25"–0.50" (6.4 MM–12.7 MM)
- 2 YOKE HUB
- 3 FACE SEAL ASSEMBLY (POSE™ SEAL ELEMENT)

5. Install the yoke or flange using the correct procedure.

NOTE

The yoke must be completely seated before tightening pinion nut to the input shaft.

Installing Any Type Yoke with a Unitized Pinion Seal (UPS)

CAUTIONS

⚠ *Once the yoke is partially or fully installed and then removed for any reason, the unitized pinion seal will be damaged and unusable. If the yoke and unitized pinion seal are removed after partial or full installation, remove and discard the original unitized pinion seal and replace it with another new unitized pinion seal.*

⚠ *If the inner sleeve of the seal is removed, the seal is not usable. A new seal is required. This will occur if a yoke is installed into the seal and then removed.*

1. Remove the replacement unitized seal from the package. Figure 4.7.
2. Select the correct seal driver from **Table A**. Each seal driver is designed to correctly install a specific diameter seal. To determine the yoke seal diameter, measure the yoke journal. Refer to **Table A**.
3. Position the seal on the driver.

Figure 4.7

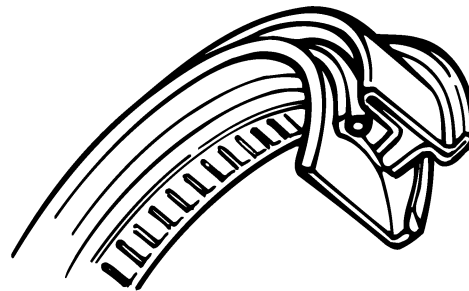

1003397a

UNITIZED SEAL

Section 4 General Information

Table A — Unitized Pinion Seals and Seal Drivers

Single Models	Tandem Models	RICO Unitized Pinion Seal	Seal Installation Location	RICO Seal Driver	Yoke Seal Diameter Inches
RS-17-145 RS-19-145 RS-21-145	RT-34-144 /P RT-34-145 /P RT-40-145 /A /P	A-1205-R-2592	Tandem Forward Input (145 models from 11/93 to present)	R4422402	3.250 3.255
RS-21-160 RS-23-160 /A RS-23-161 /A RS-25-160 /A	RT-40-149 /A /P RT-44-145 /P RT-40-160 /A /P RT-40-169 /A /P	A-1205-P-2590	Tandem Forward Output (Tandem Forward Input 145 models before 11/93 with seal A-1205-F-2424)	R4422401	3.000 3.005
RS-23-186 RS-26-185 RS-30-185	RT-46-160 /A /P RT-46-169 /A /P RT-46-164EH /P RT-46-16HEH /P RT-50-160 /P RT-52-185* RT-58-185*	A-1205-N-2588	Tandem and Single Rear Input (145 models)	R4422401	3.000 3.005
		A-1205-Q-2591	Tandem and Single Rear Input (160/164/185 models)	R4422402	3.250 3.255

T

* Forward and rear input only.



CAUTION

Use a rubber mallet to install the seal. Do not use a steel, brass or plastic hammer to install the seal. Using a steel, brass or plastic hammer can damage the seal and driver tool.

4. Use a rubber mallet to drive the seal into or against the bearing cage. The seal must fully seat into or against the bearing cage.
Figure 4.8.

Figure 4.8

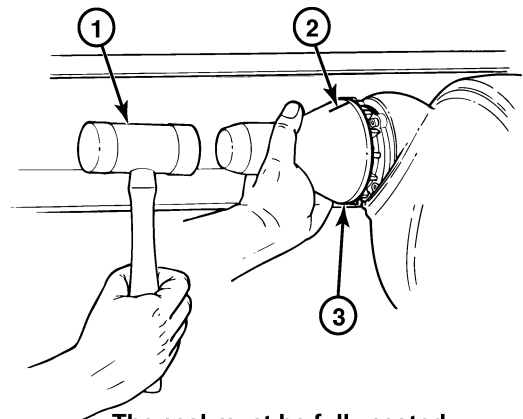

The seal must be fully seated into or against the bearing cage.

1003389a

- 1 RUBBER MALLET
- 2 REFERENCE MARK
- 3 SEAL DRIVER R4422401

Section 4 General Information

5. Use a 0.010-inch shim to check for clearance between the entire seal flange circumference and the bearing cage.
 - **If the 0.010-inch shim slides between the seal flange and bearing cage:** Correctly position the seal driver and drive the seal into the bore until the 0.010-inch shim cannot slide between the seal flange and bearing cage at any point around the seal flange. **Figure 4.9.**

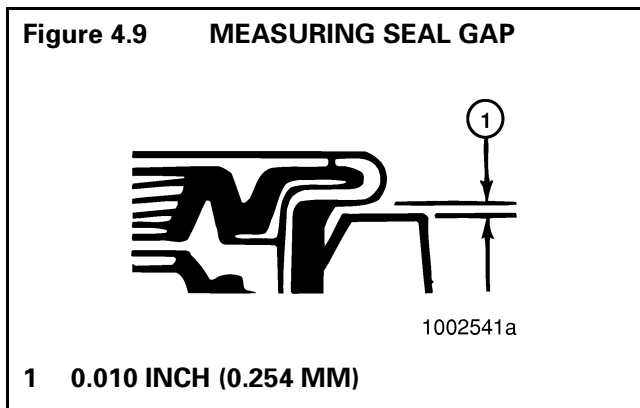

Clean, Inspect and Install the Yoke After Installing a Unitized Pinion Seal

WARNING

Solvent cleaners can be flammable, poisonous and cause burns. Examples of solvent cleaners are carbon tetrachloride, emulsion-type cleaners and petroleum-based cleaners. To avoid serious personal injury when you use solvent cleaners, you must carefully follow the manufacturer's product instructions and these procedures:

- *Wear safe eye protection.*
 - *Wear clothing that protects your skin.*
 - *Work in a well-ventilated area.*
 - *Do not use gasoline, or solvents that contain gasoline. Gasoline can explode.*
 - *You must use hot solution tanks or alkaline solutions correctly. Follow the manufacturer's instructions carefully.*
1. Clean the ground and polished surface of the yoke journal using a clean shop towel and a safe cleaning solvent. Do not use gasoline, abrasive cleaners, towels, or scrubbers to clean the yoke. Do not attempt to polish the yoke.

NOTE

The unitized seal features a rubber inner sleeve that is designed to seal and rotate with the yoke. This feature allows you to reuse a yoke with minor grooves.

2. Inspect the yoke seal surface for grooves.
 - **If you find grooves on the yoke:** Use calipers to measure the groove diameters. If any groove diameter measures less than the dimensions shown in **Figure 4.10**, replace the yoke.

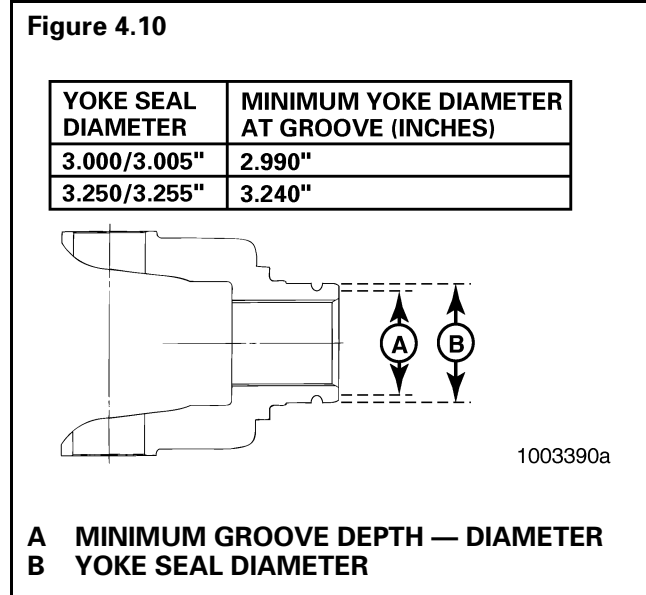

CAUTIONS

⚠ *Do not install a POSE™ seal after you install a unitized pinion seal. The use of a POSE™ seal will prevent correct seating of the unitized pinion seal on the yoke and can result in lubricant leakage at the seal. POSE™ seal installation is recommended only for triple lip and other previous design seals.*

⚠ *Do not use thin metal wear sleeves to refresh the yoke surface. Wear sleeves pressed onto the yoke can prevent correct seating of the pinion seal, damage the pinion seal assembly and can cause the seal to leak.*

3. Before you install the yoke, lightly lubricate or coat the yoke seal journal with axle oil.
4. Align the yoke splines with the shaft splines. Slide the yoke over the shaft spline.

General Yoke and U-Joint Reassembly

Install the end yoke hub capscrews by hand after seating the U-joint. Tighten the capscrews according to manufacturer's torque specifications.

Gear Set Information (Drive Pinion and Ring Gear Marks)

NOTE

Read the following information before installing a new gear set in the carrier. Always check the gear set for correct marks to make sure the gears are a matched set.

The location of the marks are shown in Figure 4.11.

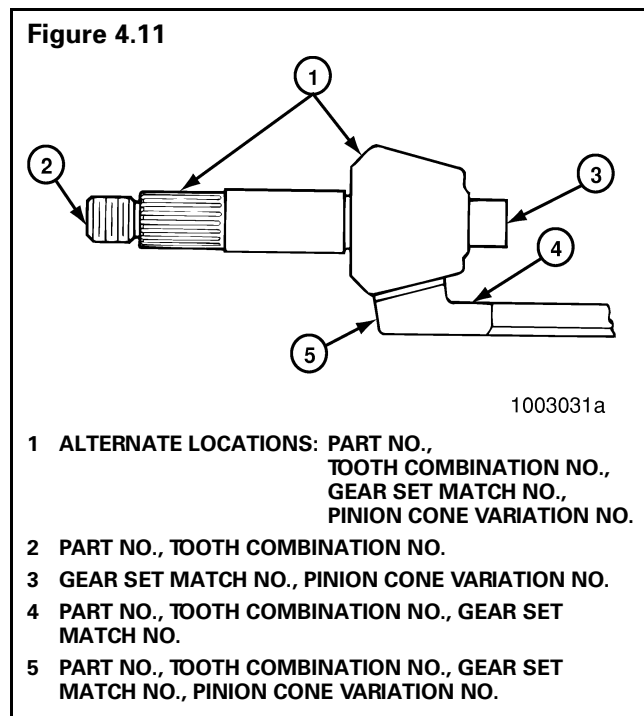

1. Part Number

a. Examples of gear set part numbers:

- Conventional ring gear, 36786.
- Conventional drive pinion, 36787.
- Generoid ring gear, 36786 K or 36786 K2.
- Generoid drive pinion, 36787 K or 36787 K2.

NOTE

The last digit in part numbers for Generoid gears is a letter or letter and number.

b. Location on Drive Pinion: End at threads.

c. Location on Ring Gear: Front face or outer diameter.

2. Tooth Combination Number

a. Example of a tooth combination number: 5-37.

NOTE

A 5-37 gear set has a 5-tooth drive pinion and a 37-tooth ring gear.

b. Location on Drive Pinion: End at threads.

c. Location on Ring Gear: Front face or outer diameter.

3. Gear Set Match Number

RICO drive pinions and ring gears are available only as matched sets. Both gears of a set have a match number.

a. Example of a gear set match number: M29.

NOTE

A gear set match number has any combination of a number or letter and number.

b. Location on Drive Pinion: End of gear head.

c. Location on Ring Gear: Front face or outer diameter.

Section 4

General Information

4. Pinion Cone Variation Number

NOTE

The pinion cone variation number is not used when checking for a matched gear set. The number is used when you adjust the depth of the pinion in the carrier. Refer to the procedure for adjusting the shim pack thickness under the pinion cage in "Adjusting Shim Pack Thickness for the Pinion Cage (Depth of Pinion)."

a. Examples — refer to **Figure 4.12**.

Pinion cone variation numbers:

- PC+3
- +2
- +0.01 mm
- PC-5
- -1
- -0.02 mm

b. Location on Gear Set: End of pinion gear head or outer diameter of ring gear.

Figure 4.12

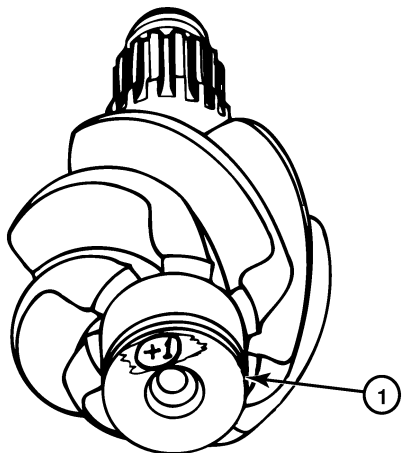

1003032a

1 PINION CONE VARIATION NUMBER

Assemble the Drive Pinion, Bearings and Bearing Cage

WARNINGS

⚠ To prevent serious eye injury, always wear safe eye protection when you perform vehicle maintenance or service.

⚠ Observe all warnings and cautions provided by the press manufacturer to avoid damage to components and serious personal injury.

1. Place the bearing cage in a press. **Figure 5.1.**

Figure 5.1

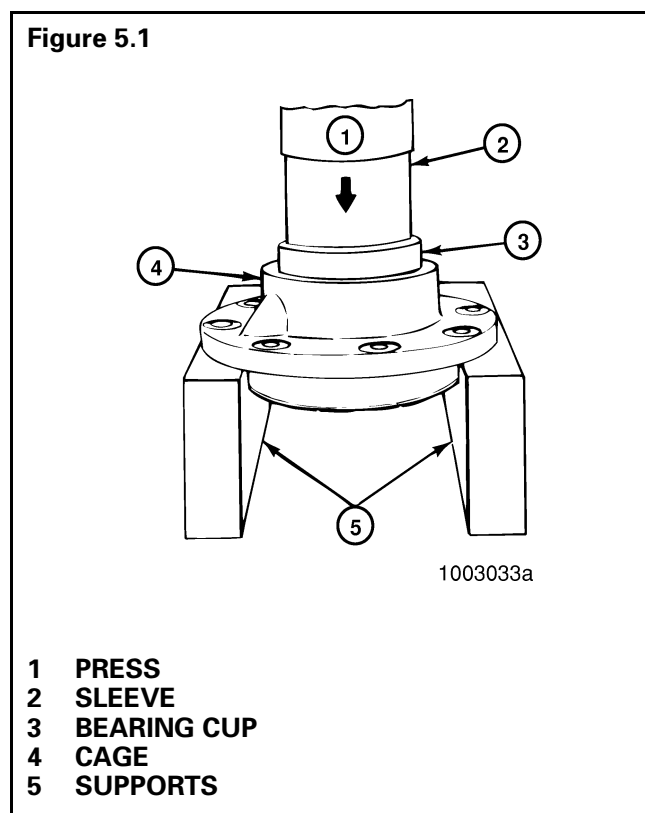

2. Support the bearing cage with metal or wood blocks.
3. Press the bearing cup into the bore of bearing cage until cup is flat against bottom of bore. Use a sleeve of the correct size to install bearing cup. **Figure 5.1.**

NOTE

Use the same procedure for both bearing cups.

4. Place the drive pinion in a press, gear head (teeth) toward the bottom. **Figure 5.2.**

Figure 5.2

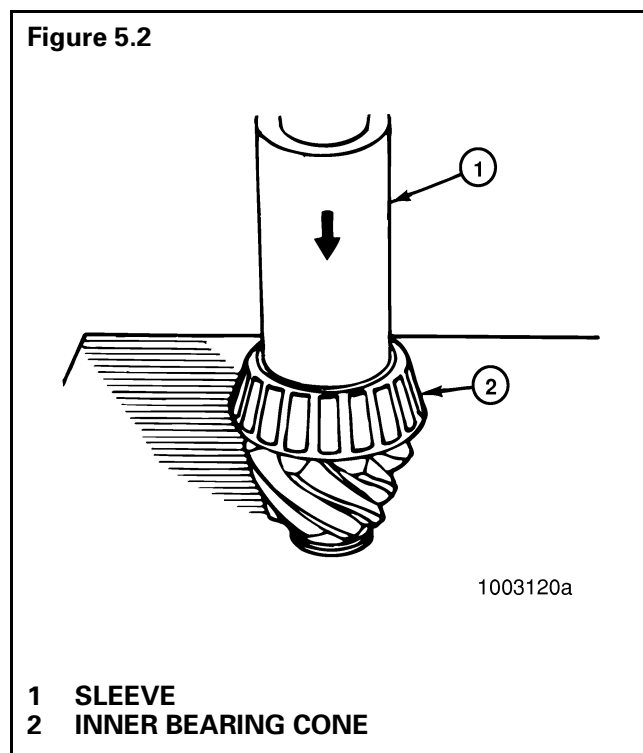

5. Press the inner bearing cone on the shaft of the drive pinion until the cone is flat against the gear head. Use a sleeve of the correct size against the bearing inner race.

NOTE

Spigot bearings are usually fastened to the drive pinion with a snap ring. Some are fastened with a peening tool, and some are a two-piece bearing assembly with the inner race pressed on the nose of the pinion and the outer race pressed into its bore in the carrier. Use the following procedure to install the spigot bearing.

Section 5 Assembly

NOTE

The following procedure applies to all axles except:

- Some 160 Series single axles may use snap rings.
- Some 160 and 180 Series rear rear tandem axles may use snap rings.

6. Installing the One-Piece Spigot Bearing on the Drive Pinion with Snap Ring

- Place the drive pinion in a press, gear head (teeth) toward the top. **Figure 5.3.**
- Press the spigot bearing on the end of drive pinion until the bearing is flat against the gear head. Use a sleeve of the correct size against the bearing inner race. **Figure 5.3.**

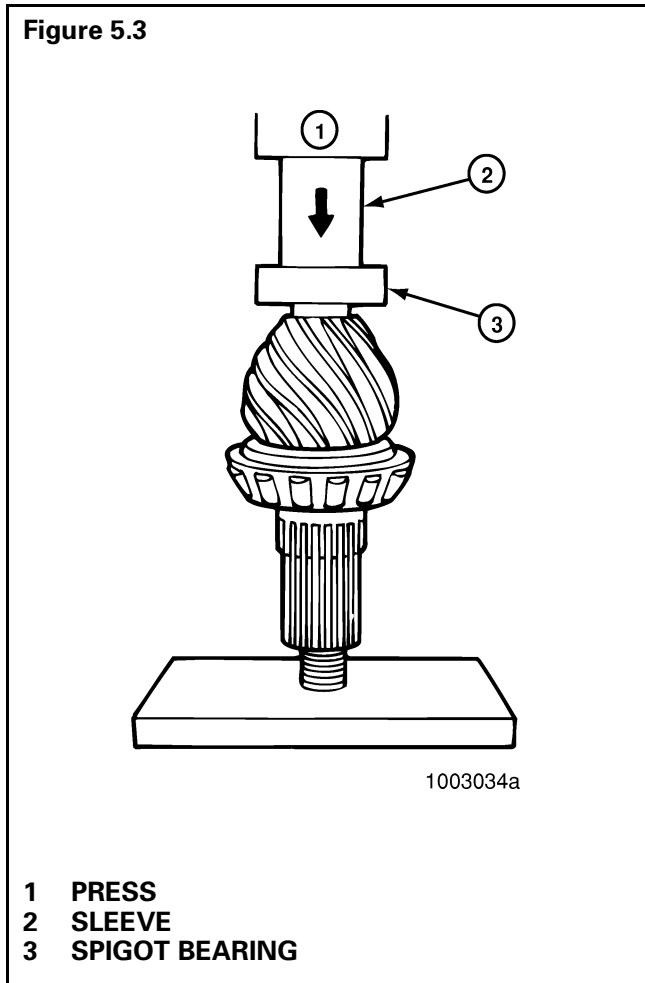

- Install the snap ring* into groove in end of drive pinion with snap ring pliers. **Figure 5.4.**

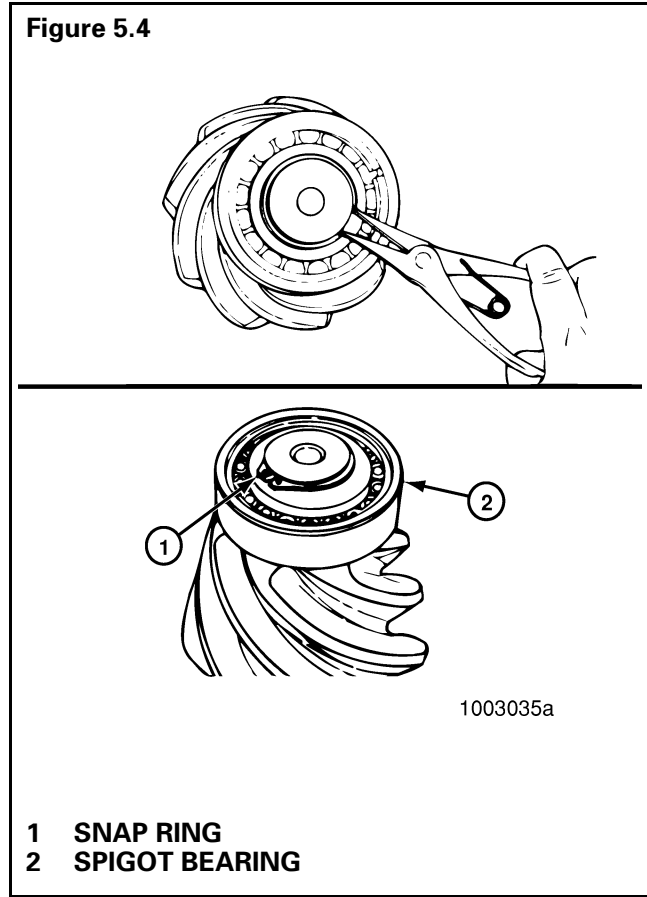

NOTE

The following procedure applies to some 180 Series rear rear tandem axles with existing snap ring components.

7. Staking the One-Piece Spigot Bearing on the Drive Pinion (Without Snap Ring)

Specification

- Apply 6,614 lb. (3,000 kg) force on a 0.375-inch (10 mm) ball.
- Stake the end of drive pinion at a minimum of five points. **Figure 5.5.**

Figure 5.5

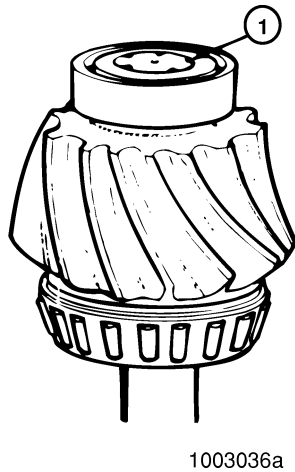

1 STAKING POINTS

When using a staking tool and press (Figure 5.5), calculate the force required on the tool as follows.

$$6,614 \text{ lb. (3,000 kg)} \times \text{amount of balls in tool} = \text{pounds or kilograms}$$

Example

$$6,614 \text{ lb.} \times 3 \text{ balls} = 19,842 \text{ pounds}$$

For information about the staking tool, contact your local RICO representative. Figure 5.6.

Figure 5.6

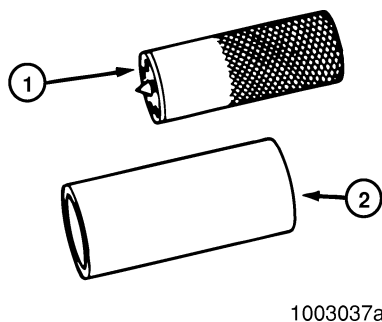

- 1 PUNCH
- 2 TUBE

- a. Place the drive pinion and the tube of the staking tool in a press, spigot bearing toward the top. Figure 5.7.
- b. Calculate the amount of force that will be required on the staking tool. Refer to specification and example calculation.
- c. Place the punch of the staking tool over the end of the pinion and spigot bearing. Apply the required amount of force on the punch. Figure 5.7.

Figure 5.7

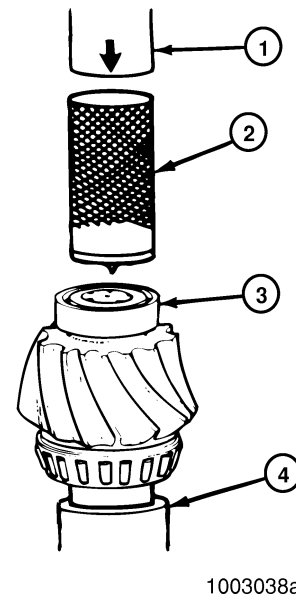

- 1 PRESS
- 2 INSTALL AND CENTER THE PUNCH ON THE END OF PINION
- 3 SPIGOT BEARING
- 4 PUT THE SHAFT OF PINION INTO TUBE

CAUTION

Do not align new points with grooves in end of drive pinion or in old points. If the new staked points are placed in the wrong areas, the spigot bearing will not be held correctly on the pinion shaft.

- d. Rotate the punch as many times as required for a minimum of five points. Repeat step c for each point.

NOTE

If a three-ball stake tool is used, rotate the tool 180° (degrees).

Section 5 Assembly

8. Installing and Staking the Two-Piece Spigot Bearing on the Drive Pinion

NOTES

- *This procedure applies to some 160 Series single rear axles and rear rear tandem axles. These axles may also use a one-piece spigot bearing with a snap ring retainer.*
- *The inner race of two-piece spigot bearings must be staked in place on RS and RR-160 series rear axles. Before you stake the pinion, you must heat the pinion stem to soften it.*
- *Kent-Moore Kit J-39039 includes the staking tool, temperature indicating liquid, heating shield and plastigage needed for this job.*
 - a. Apply two stripes of temperature indicating liquid on the pinion stem from the top to the bottom. **Figure 5.8.** Apply a green stripe to indicate 400°F (205°C) and a blue stripe to indicate 500°F (260°C).

Figure 5.8

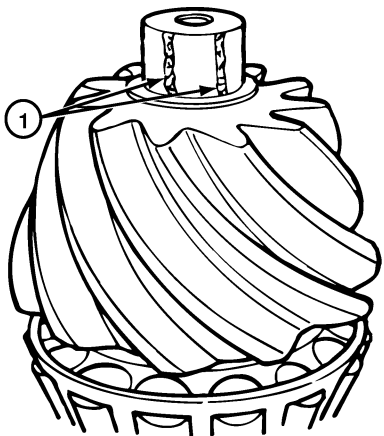

1003039a

1 TEMPERATURE INDICATING LIQUID APPLICATION

- a. Place the heating shield over the pinion stem so that you can see the temperature indicating liquid through the hole in the shield. **Figure 5.9.**

Figure 5.9

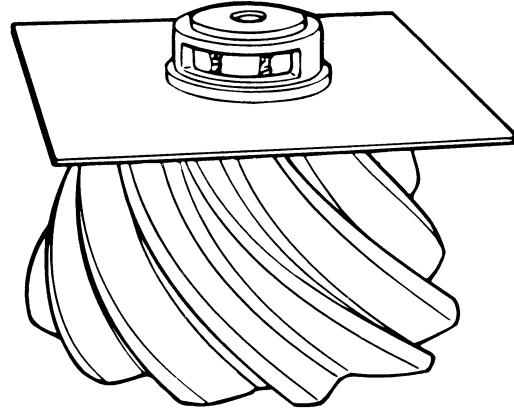

1001040a

⚠ WARNING

Always wear safe clothing, gloves and eye protection when working with a torch for heating parts to prevent serious personal injury during assembly.

⚠ CAUTION

Do not heat the pinion stem without the heat shield in place. Also, do not overheat the pinion stem or you will weaken the metal which can cause early failure. Correct heating will take approximately 25-35 seconds, depending on how hot the torch is.

- a. Light and adjust the torch until the white part of the flame is approximately 1/4 inch long. Keep the white part of the flame approximately 1/8 inch from the top of the stem. **Figure 5.10.** Move the flame around the outer diameter of the top of the pinion stem. The green temperature indicating liquid will turn black before the blue liquid does. Heat the stem until the blue liquid turns black at a point in the middle of the window.

Figure 5.10

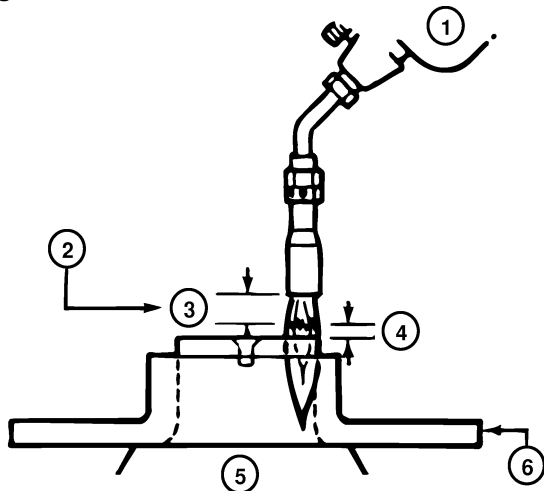

1003041a

- | | |
|-----------------------|------------------|
| 1 TORCH | 4 1/8" |
| 2 WHITE PART OF FLAME | 5 PINION |
| 3 1/4" | 6 HEATING SHIELD |

- d. Remove the flame and the heat shield from the pinion. Let the pinion air cool for 10 minutes. Use a razor blade to remove the temperature indicating liquid.

WARNING

Observe all warnings and cautions provided by the press manufacturer to avoid damage to components and serious personal injury.

CAUTION

Do not press or directly strike the new inner race in step e or damage to the bearing will result.

- e. Use a press, if available, or a brass hammer to install the new inner race. Use the old inner race as a sleeve. The face is completely seated when you cannot fit a 0.002-inch feeler gauge between the race and the pinion shoulder.

NOTES

- To hold the races in place, use a staking tool, instead of the old race, to start the new race on the stem. The old race can be used to completely seat the new race.
- In step f, you do not need to use the plastigage for every stake. Use the plastigage until you are sure you are hitting the punch with the correct amount of force.

- f. Place the staking tool over the bearing race. Cut a one inch piece from the green plastigage strip and place in between the punch and the staking tool. Figure 5.11 — View A.

Figure 5.11

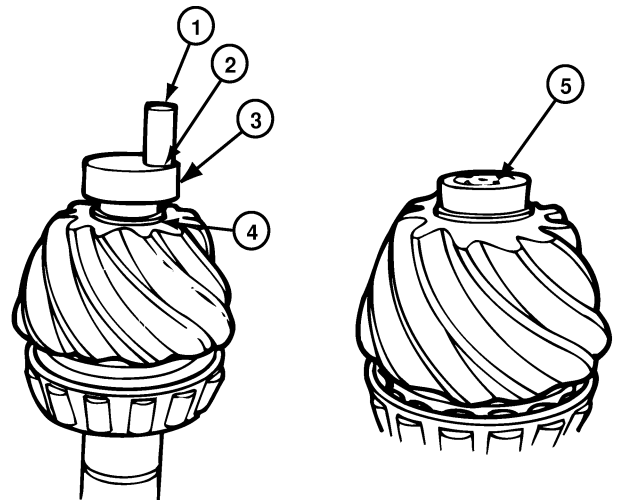

*

**

1003042a

- | |
|----------------------|
| 1 PUNCH |
| 2 PLASTIGAGE |
| 3 STAKING TOOL |
| 4 BEARING INNER RACE |
| 5 STAKES |
| * VIEW A |
| ** VIEW B |

- g. Strike the punch with a two-three pound brass hammer to upset the end of the pinion stem. Then, remove the strip and measure its thickness against the gauge on the wrapper that the strip came in. The strip must not be less than 0.003 inch thick. This thickness indicates that you are using enough force when you hit the punch. If the strip is too thin, then you must hit the punch harder so the stake will hold the race in place. Rotate the tool and repeat this procedure until there are six evenly spaced stake marks around the stem. Figure 5.11 — View B.

- h. With a press or a soft mallet and sleeve, install the outer race and roller assembly into its bore in the carrier. Use a sleeve that is the same size as the outer race and press the bearing until it is squarely against the shoulder in the bottom of its bore.

Section 5 Assembly

9. Apply axle lubricant to the bearing cups and to the bearing cones in the cage.
10. Install the drive pinion into the bearing cage.
11. Install the bearing spacer or spacers on pinion shaft against the inner bearing cone.
Figure 5.12.

NOTE

The spacer or spacers control the preload adjustment of the drive pinion bearings.

12. Install the outer bearing cone on pinion shaft against the spacer. **Figure 5.12.**

NOTE

DO NOT install pinion seal in bearing cage. Continue with adjusting preload of pinion bearings.

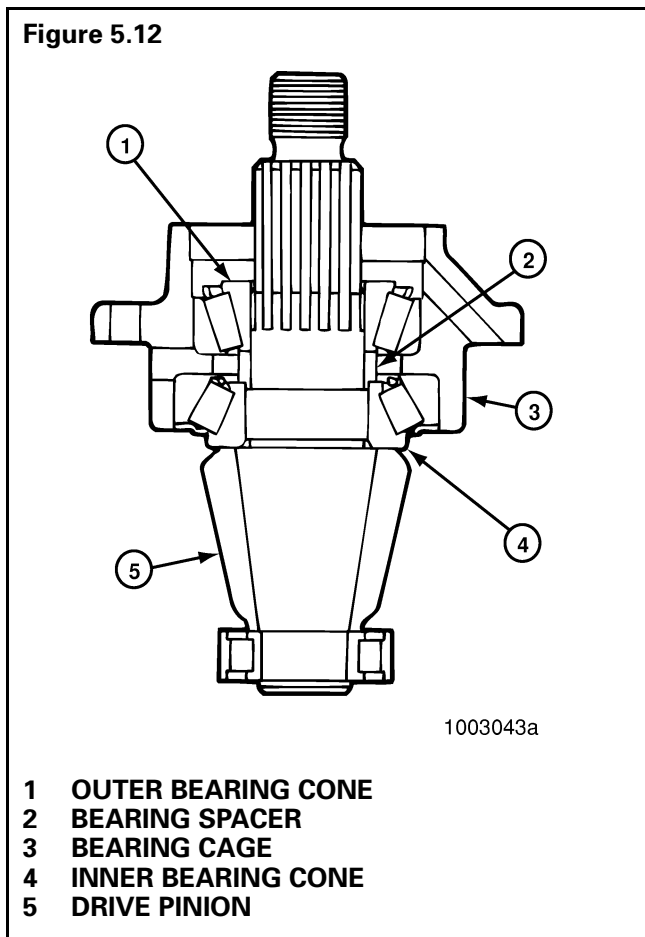

Adjusting Preload of Pinion Bearings

Specifications

- New pinion bearings — torque
— 5 to 45 lb-in (0.56-5.08 N•m) **T**
- Used pinion bearing in good condition — torque
— 10 to 30 lb-in (1.13-3.39 N•m) **T**

Press Method

NOTES

- *If a press is not available, or the press does not have a pressure gauge, use the yoke or flange method to adjust pinion bearing preload. Refer to "Yoke or Flange Method."*
 - *Do not read starting torque. Read only the torque value after the cage starts to rotate. Starting torque will give a false reading.*
- a. Place the drive pinion and cage assembly in a press, gear head (teeth) toward the bottom.
 - b. Install a sleeve of the correct size against the inner race of the outer bearing **Figure 5.13**.
 - c. Apply and hold the correct amount pressure to the pinion bearings. Refer to **Table B**. As pressure is applied rotate the bearing cage several times so that bearings make normal contact.

Table B

Thread Size of Pinion Shaft	Press Pressure Needed on Bearings for Correct Preload.		Torque Value Needed on Pinion Nut for Correct Bearing Preload.	
	pounds/tons	(kg/metric tons)	lb-ft	(N•m)
7/8"-20	22,000/1	(9979/10)	200-275	(271-373)
1"-20	30,000/15	(13608/13.6)	300-400	(407-542)
1 1/4"-12	54,000/27	(24494/24.5)	700-900	(949-1220)
1 1/4"-18	54,000/27	(24494/24.5)	700-900	(949-1220)
1 1/2"-12	54,000/27	(24494/24.5)	800-1100	(1085-1491)
1 1/2"-18	54,000/27	(24494/24.5)	800-1100	(1085-1491)
1 3/4"-12	50,000/25	(22680/22.7)	900-1200	(1220-1627)
2"-12	50,000/25	(22680/22.7)	1200-1500	(1627-2034)

- d. While pressure is held against the assembly, wind a cord around the bearing cage several times.
- e. Attach a spring scale to the end of the cord.
- f. Pull the cord with scale on a horizontal line. As the bearing cage rotates, read the value indicated on scale. Write down and record the reading. **Figure 5.13.**
- g. Measure the diameter of bearing cage where the cord was wound. Measure in inches or centimeters. **Figure 5.14.**
- h. Divide the dimension in half to get the radius. Write down and record the radius dimension.

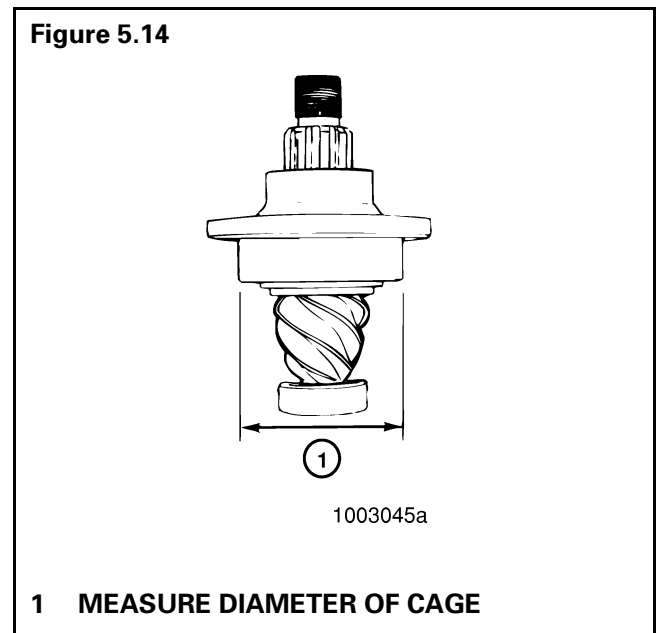
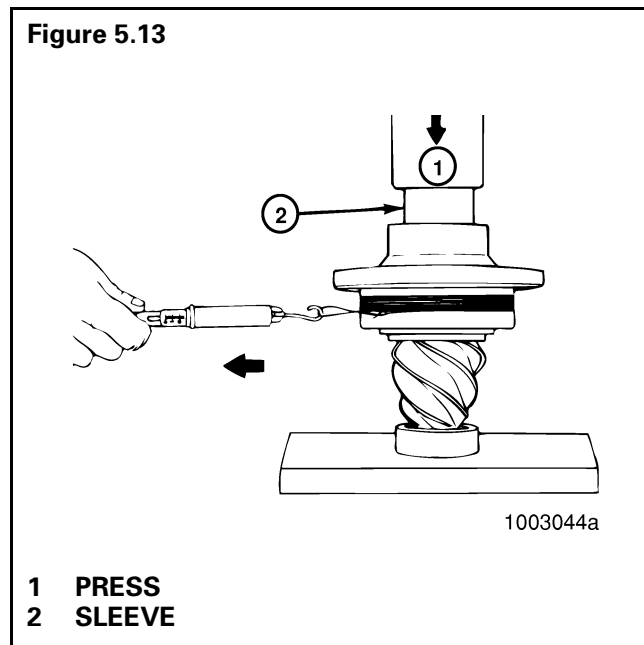

Section 5 Assembly

i. Use the following procedure to calculate the bearing preload (torque).

- Pounds Pulled x Radius (inches) = lb-in Preload
— Preload x 0.113 = N•m Preload
- Kilograms Pulled x Radius (cm) = kg-cm Preload
— Preload x 0.098 = N•m Preload

or

Examples

- Reading from spring scale = 7.5 pounds (3.4 kg)
 - Diameter of bearing cage = 6.62 inches (16.8 cm)
 - Radius of bearing cage = 3.31 inches (8.4 cm)
- 7.5 lb. x 3.31 in. = 24.8 in-lb Preload
Preload x 0.113 = 2.8 N•m Preload

or

3.4 kg x 8.4 cm = 28.6 kg-cm Preload
Preload x 0.098 = 2.8 N•m Preload

j. If the preload (torque) of pinion bearings is not within specifications, do the following procedure then repeat steps a through i.

To increase preload, install a thinner bearing spacer. To decrease preload, install a thicker bearing spacer.

k. Check the bearing preload with the drive pinion and cage assembly installed in the carrier. Follow the procedures to adjust preload of pinion bearings, yoke or flange method.

Yoke or Flange Method

WARNING

Observe all warnings and cautions provided by the press manufacturer to avoid damage to components and serious personal injury.

CAUTION

Do not install tight fit yokes or flanges on shafts using a hammer or mallet. A hammer or mallet will damage the yoke or flange.

NOTE

Use a press to install the yoke or flange. Figure 5.15.

- a. Install the input yoke or flange, nut and washer* on the drive pinion. The yoke or flange **must** be seated against the outer bearing.
- b. Temporarily install the drive pinion and cage assembly in the carrier. Do not install shims under the bearing cage. Figure 5.16.

Figure 5.15

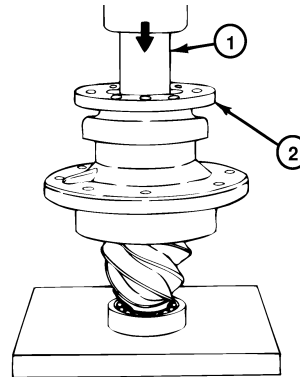

- 1 PRESS
- 2 INPUT FLANGE SHOWN

Figure 5.16

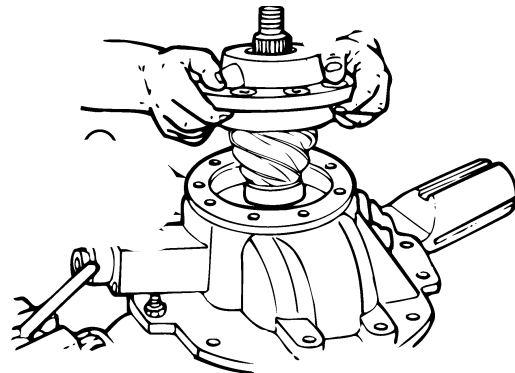

Section 5 Assembly

- c. Install the bearing cage to carrier capscrews. Washers are not required at this time. Tighten the capscrews by hand until snug.
- d. Fasten a yoke or flange bar to the input yoke or flange. The bar will hold the drive pinion in position when the nut is tightened. **Figure 5.17.**

Figure 5.17

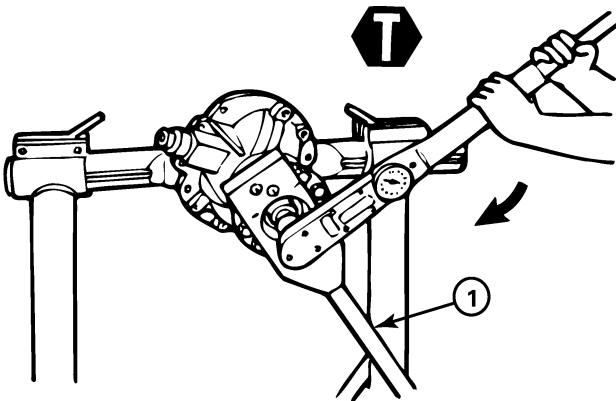

1 FLANGE BAR SHOWN

- e. Tighten the nut on drive pinion to the correct torque value. **Figure 5.17.** Refer to **Table B.**
- f. Remove the yoke or flange bar.
- g. Attach a torque wrench on the drive pinion nut. Rotate the drive pinion and read the value indicated on torque wrench. **Figure 5.18.**

Figure 5.18

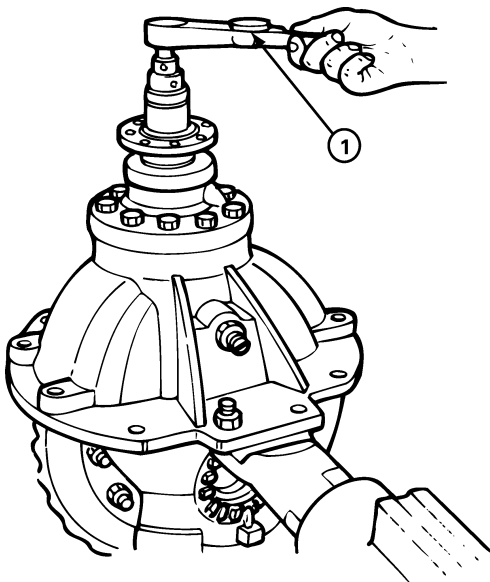

1 READ TORQUE VALUE

- h. If the preload (torque) of pinion bearings is not within specifications, remove the pinion and cage assembly from carrier. Do the following procedure then repeat steps **a** through **g**.

- To **increase** preload, install a thinner bearing spacer.
- To **decrease** preload, install a thicker bearing spacer.

13. After adjusting preload of pinion bearings, remove the drive pinion and bearing cage from carrier. Follow steps 1-5 in "Remove the Drive Pinion and Bearing Cage from Carrier."

14. Install a new triple-lip seal as follows.

CAUTION

Make sure that the seal lips are clean and free from dirt and particles that will cause a leak between the yoke and the seal.

- a. Apply the same lubricant used in the axle housing to the outer surface of the seal and the seal bore in the bearing cage. **Figure 5.19.**

Figure 5.19

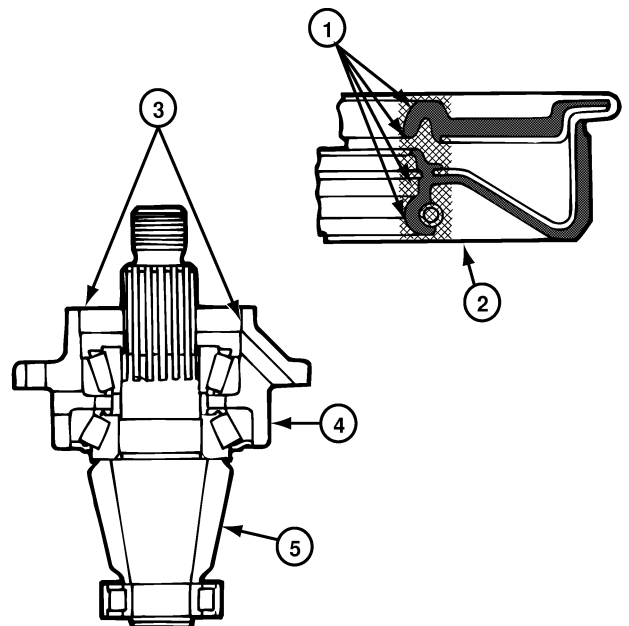

1003050a

- 1 APPLY GREASE**
- 2 TRIPLE-LIP (MAIN) SEAL**
- 3 APPLY LUBRICANT TO SEAL BORE**
- 4 BEARING CAGE**
- 5 DRIVE PINION**

Section 5 Assembly

- b. Place the drive pinion and cage assembly in a press, seal bore toward the top.

NOTE

If a press is not available, use a mallet and the sleeve or driver to install the seal. Figure 5.21.

- c. Press the seal into bearing cage until flange of seal is flat against the top of bearing cage. Use a sleeve or seal driver of the correct size that fits against the metal flange of seal. The diameter of the sleeve or driver **must** be larger than the diameter of the flange. **Figure 5.20.**

Figure 5.20

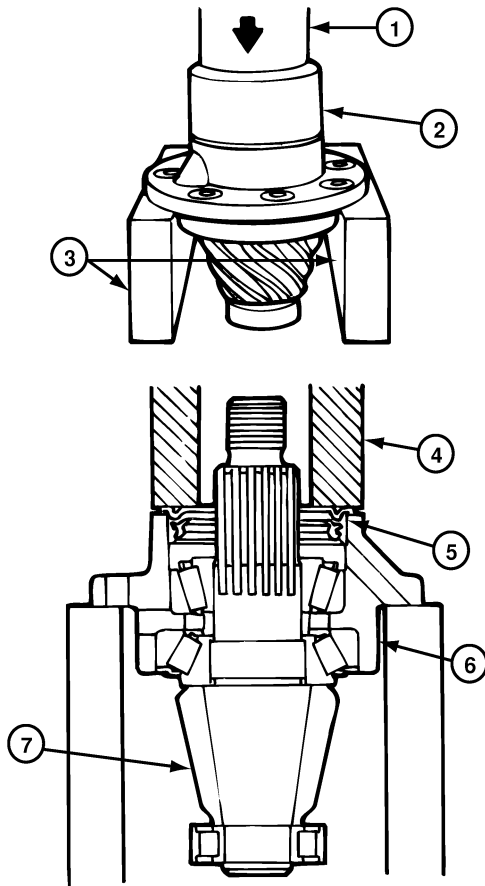

1003051a

- 1 PRESS
- 2 SLEEVE
- 3 SUPPORTS
- 4 SLEEVE
- 5 SEAL
- 6 BEARING CAGE
- 7 DRIVE PINION

Figure 5.21

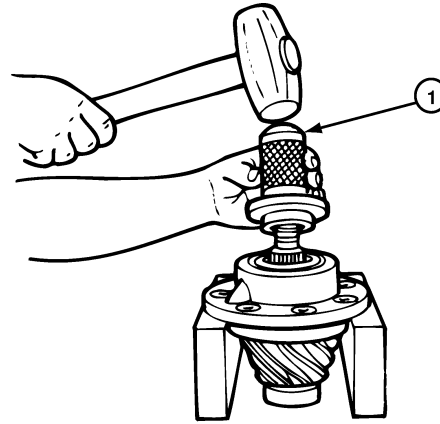

1003052a

- 1 SEAL DRIVER

WARNING

Use a brass or leather mallet for assembly and disassembly procedures. Do not hit steel parts with a steel hammer. Pieces of a part can break off and cause serious personal injury.

- d. After the triple-lip seal is installed, a gap of approximately 0.015 to 0.030 inch (0.38-0.76 mm) between the flange and bearing cage is normal. **Figure 5.22.**

Check the gap with a feeler gauge at several points around the seal. The gap must be within 0.015 to 0.030 inch (0.38-0.76 mm). The difference between the largest and smallest gap measurement **must not** exceed 0.010 inch (0.0254 mm).

Figure 5.22

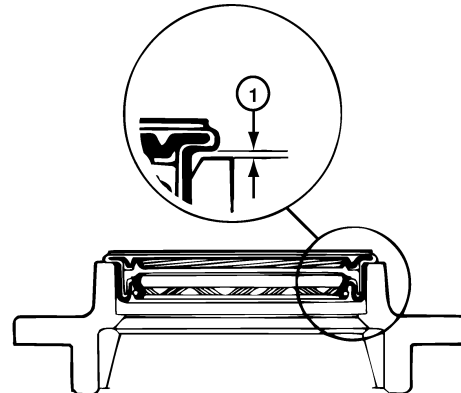

1003053a

- 1 0.015-0.030" (0.38-0.76 MM)
SHOWN WITHOUT BEARINGS AND PINION

Adjusting Shim Pack Thickness for the Pinion Cage (Depth of Pinion)

NOTE

Use this procedure if a new drive pinion and ring gear set is installed, or if the depth of the drive pinion has to be adjusted. Figure 5.23.

Figure 5.23

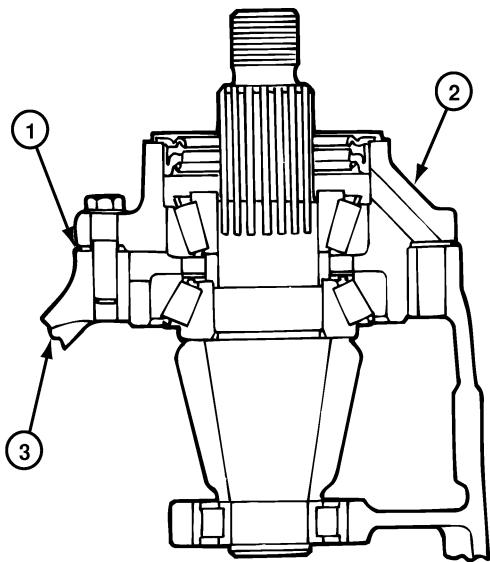

1003054a

- 1 SHIM PACK CONTROLS DEPTH OF PINION
- 2 BEARING CAGE
- 3 CARRIER

1. Measure the thickness of the old shim pack that was removed from under the pinion cage with a micrometer. Record the measurement for use later. Figure 5.24.

Figure 5.24

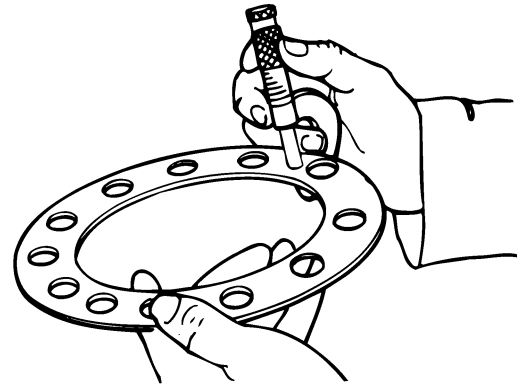

1003055a

2. Look at the pinion cone (PC) variation number on the old drive pinion that is being replaced. Refer to Gear Set Information at the end of Section 4 for examples and location of the number. Record the number for later use. If (PC) variation number cannot be located, assemble gear set with shim pack thickness found in step 1. Figure 5.25.

Figure 5.25

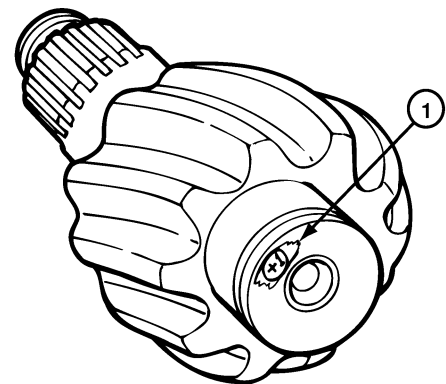

1003056a

- 1 PINION CONE VARIATION NUMBER

Section 5 Assembly

NOTE

The pinion cone number can be either 100ths of a millimeter or 1,000ths of an inch. Refer to the following examples:

PC +3, PC -3, +3 or -3 = 0.003 inch

PC +.03, PC 0.03 mm, +0.03 mm or
-0.03 = 0.03 mm

To change millimeters to inches —
millimeters x 0.039

To change inches to millimeters —
inches x 25.40

- If the old pinion cone number is a plus (+) number, subtract the number from the old shim pack thickness that was measured in step 2.
- If the old pinion cone number is a minus (-) number, add the number to the old shim pack thickness that was measured in step 2.

NOTE

The value calculated in step 3 or 4 is the thickness of the standard shim pack, without a variation.

- Look at the pinion cone (PC) variation number on the new drive pinion that will be installed. Record the number for later use.
- If the new pinion cone number is a plus (+) number, add the number to the standard shim pack thickness that was calculated in step 3 or 4.
- If the new pinion cone number is a minus (-) number, subtract the number from the standard shim pack thickness that was calculated in step 3 or 4.

NOTE

The value calculated in step 6 or 7 is the thickness of the new shim pack that will be installed. Refer to the following examples, Table C.

- Install the drive pinion bearing cage and new shim pack into the carrier.

Table C

Examples	Inches	mm
1. Old Shim Pack Thickness Old PC Number, PC +2 inches (+0.05 mm) Standard Shim Pack Thickness New PC Number, PC +5 inches (+0.13 mm) New Shim Pack Thickness	$0.030 - 0.002 = 0.028$ $+ 0.005 = 0.033$	$0.760 - 0.050 = 0.710$ $+ 0.130 = 0.840$
2. Old Shim Pack Thickness Old PC Number, PC -2 inches (-0.05 mm) Standard Shim Pack Thickness New PC Number, PC +5 inches (+0.13 mm) New Shim Pack Thickness	$0.030 + 0.002 = 0.032$ $+ 0.005 = 0.037$	$0.760 + 0.050 = 0.810$ $+ 0.130 = 0.940$
3. Old Shim Pack Thickness Old PC Number, PC +2 inches (+0.05 mm) Standard Shim Pack Thickness New PC Number, PC -5 inches (-0.13 mm) New Shim Pack Thickness	$0.030 - 0.002 = 0.028$ $- 0.005 = 0.023$	$0.760 - 0.050 = 0.710$ $- 0.130 = 0.580$
4. Old Shim Pack Thickness Old PC Number, PC -2 inches (-0.05 mm) Standard Shim Pack Thickness New PC Number, PC -5 inches (-0.13 mm) New Shim Pack Thickness	$0.030 + 0.002 = 0.032$ $- 0.005 = 0.027$	$0.760 + 0.050 = 0.810$ $- 0.130 = 0.680$

NOTE

Drive pinions and ring gears MUST be replaced as fully matched sets.

Installing the Drive Pinion, Bearing Cage and Shim Pack into the Carrier

NOTE

If a new drive pinion and ring gear set is installed, or if the depth of the drive pinion has to be adjusted, calculate the thickness of the shim pack. Refer to the procedure "Adjusting Shim Pack Thickness for the Pinion Cage (Depth of Pinion)."

1. Select the correct shim pack between the bearing cage and carrier. **Figure 5.26.**
2. Apply Loctite® 518 Gasket Eliminator to face of carrier.
3. Align the oil slots in the shims with oil slots in the bearing cage and carrier. The use of guide studs will help align the shims. **Figure 5.26.**

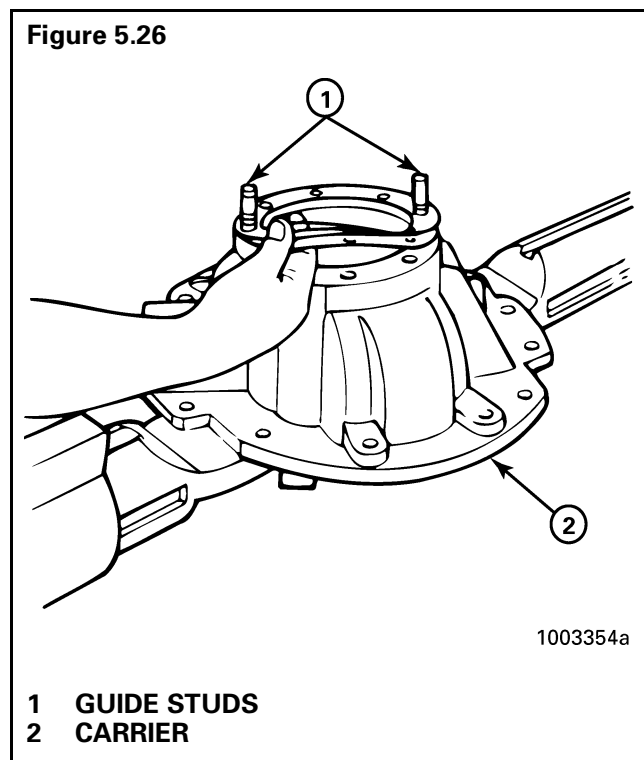

NOTE

If the pack is made from different thickness shims, install the thinnest shims on both sides of the pack for maximum sealing.

4. Apply Loctite® 518 Gasket Eliminator to top of shim pack.

WARNING

Use a brass or leather mallet for assembly and disassembly procedures. Do not hit steel parts with a steel hammer. Pieces of a part can break off and cause serious personal injury.

5. Install the drive pinion and bearing cage into the carrier. If necessary, use a rubber, plastic or leather mallet to hit the assembly into position. **Figure 5.27.**

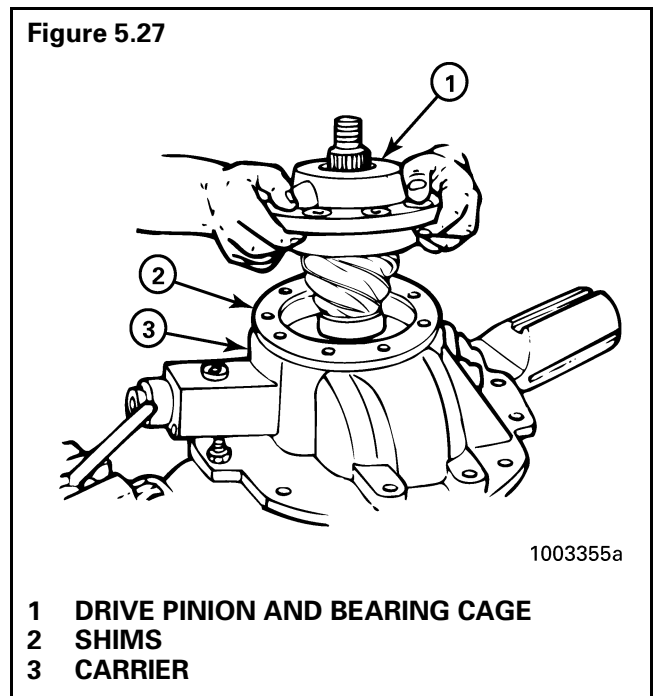

6. Install the bearing cage to carrier capscrews and washers. Tighten capscrews to correct torque value. Refer to **Table J. Figure 5.28.**

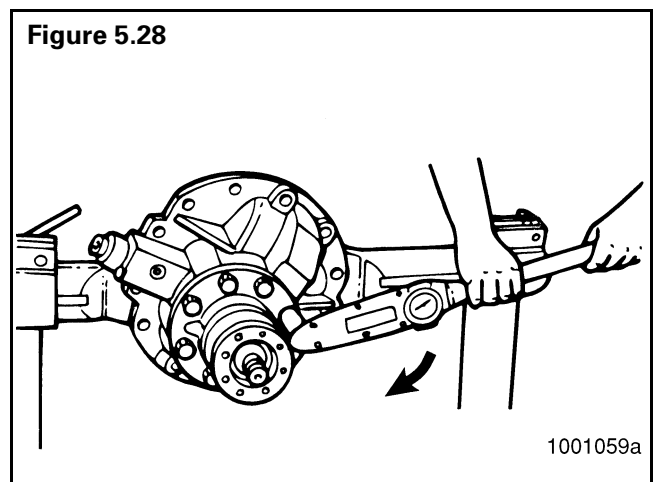

Section 5 Assembly

Installing Tight Fit Yokes and POSE™ Seal

CAUTIONS

⚠ **Make sure that the seal lips are clean and free from dirt and particles that will cause a leak between the yoke and the seal.**

⚠ **Do not install tight fit yokes on shafts using a hammer or mallet. Using a hammer or mallet can damage the yoke.**

⚠ **Make sure that the seal lips are clean and free from dirt and particles that can cause a leak between the yoke and the POSE™ seal.**

NOTE

DO NOT install POSE™ seal all the way against the yoke shoulder. This seal is designed to position itself as yoke is installed.

1. Apply axle lubricant on the yoke seal.
2. Check all surfaces of the yoke hub for damage.

If carrier uses a POSE™ seal element, install a new POSE™ seal as follows:

- a. Lightly lubricate yoke journal with same lubricant used in the axle housing.
- b. Partially install the POSE™ seal onto the yoke to 1/4 inch-1/2 inch as shown in **Figure 5.29**.

Figure 5.29

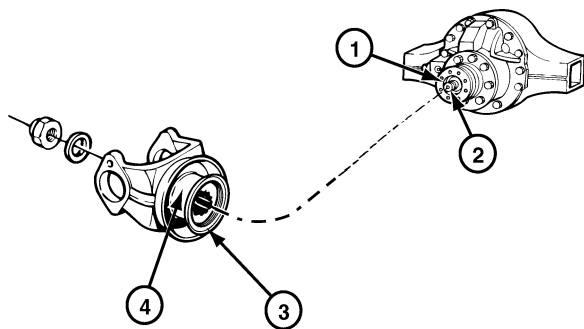

- 1 LUBRICATE TRIPLE-LIP (MAIN) SEAL
- 2 INPUT SHAFT (PINION)
- 3 POSE™ SEAL (0.25"-0.50" ONTO HUB)
- 4 CHECK YOKE HUB

- c. Before installing the yoke onto the drive pinion, lubricate the yoke again with the same lubricant used in the axle housing.
3. Slide the yoke over the input shaft pinion. Align the yoke splines with the shaft splines.

⚠ CAUTION

Do not use a hammer or mallet to install the yoke to the input pinion shaft. Using a hammer or mallet can damage the yoke or flange.

4. Install the input yoke flange onto the drive pinion shaft. The yoke or flange must be fully seated against the outer differential bearing **before** the nut is torqued to specifications.
5. Install the drive pinion nut and washer* on the input pinion shaft and against the yoke collar. Tighten the nut against yoke collar to torque specifications. **Figure 5.30**. Refer to **Table J**.

Figure 5.30

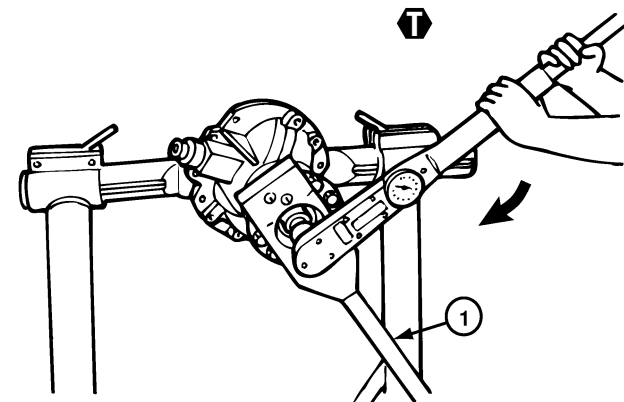

- 1 USE FLANGE OR YOKE BAR

Installing Any Type Yoke with a Unitized Pinion Seal (UPS)

CAUTIONS

⚠ *Once the yoke is partially or fully installed and then removed for any reason, the unitized pinion seal will be damaged and unusable. If the yoke and unitized pinion seal are removed after partial or full installation, remove and discard the original unitized pinion seal and replace it with another new unitized pinion seal.*

⚠ *If the inner sleeve of the seal is removed, the seal is not usable. A new seal is required. This will occur if a yoke is installed into the seal and then removed.*

1. Remove the replacement unitized seal from the package. **Figure 5.31**.
2. Select the correct seal driver from **Table D**. Each seal driver is designed to correctly install a specific diameter seal. To determine the yoke seal diameter, measure the yoke journal. Refer to **Table D**.
3. Position the seal on the driver.

Figure 5.31

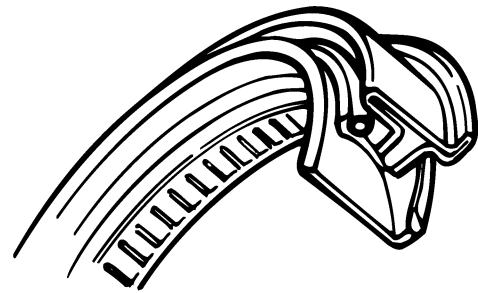

1003397a

UNITIZED SEAL

Table D — Unitized Pinion Seals and Seal Drivers

Single Models	Tandem Models	RICO Unitized Pinion Seal	Seal Installation Location	RICO Seal Driver	Yoke Seal Diameter Inches
RS-17-145	RT-34-144 /P	A-1205-R-2592	Tandem Forward Input (145 models from 11/93 to present)	R4422402	3.250
RS-19-145	RT-34-145 /P				3.255
RS-21-145	RT-40-145 /A /P	A-1205-P-2590	Tandem Forward Output (Tandem Forward Input 145 models before 11/93 with seal A-1205-F-2424)	R4422401	3.000
RS-21-160	RT-40-149 /A /P				3.005
RS-23-160 /A	RT-44-145 /P	A-1205-N-2588	Tandem and Single Rear Input (145 models)	R4422401	3.000
RS-23-161 /A	RT-40-160 /A /P				3.005
RS-25-160 /A	RT-40-169 /A /P	A-1205-Q-2591	Tandem and Single Rear Input (160/164/185 models)	R4422402	3.250
RS-23-186	RT-46-160 /A /P				3.255
RS-26-185	RT-46-169 /A /P				
RS-30-185	RT-46-164EH /P				
	RT-46-16HEH /P				
	RT-50-160 /P				
	RT-52-185*				
	RT-58-185*				

To obtain RICO seal driver KIT 4454, call 888-725-9355.

* Forward and rear input only.

Section 5 Assembly

CAUTION

Use a rubber mallet to install the seal. Do not use a steel, brass or plastic hammer to install the seal. Using a steel, brass or plastic hammer can damage the seal and driver tool.

4. Use a rubber mallet to drive the seal into or against the bearing cage. The seal must fully seat into or against the bearing cage. **Figure 5.32.**

Figure 5.32

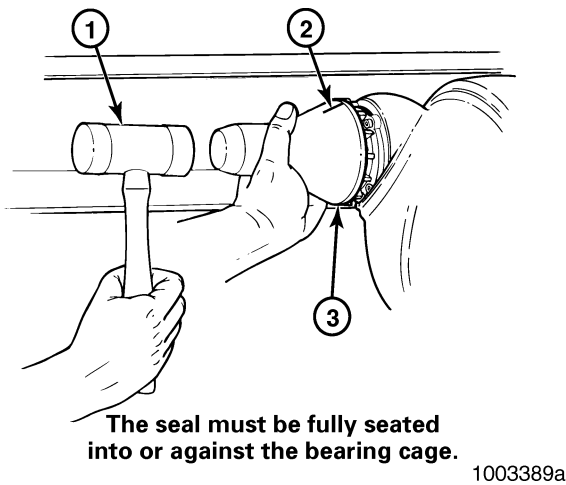

- 1 RUBBER MALLET
- 2 REFERENCE MARK
- 3 SEAL DRIVER R4422401

5. Use a 0.010-inch shim to check for clearance between the entire seal flange circumference and the bearing cage.
 - **If the 0.010-inch shim slides between the seal flange and bearing cage:** Correctly position the seal driver and drive the seal into the bore until the 0.010-inch shim cannot slide between the seal flange and bearing cage at any point around the seal flange. **Figure 5.33.**

Figure 5.33 MEASURING SEAL GAP

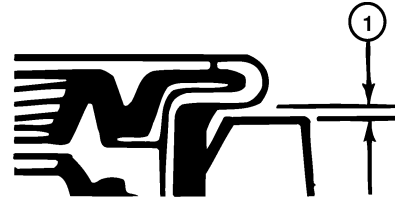

1002541a

- 1 0.010 INCH (0.254 MM)

Clean, Inspect and Install the Yoke After Installing a Unitized Pinion Seal

WARNING

Solvent cleaners can be flammable, poisonous and cause burns. Examples of solvent cleaners are carbon tetrachloride, emulsion-type cleaners and petroleum-based cleaners. To avoid serious personal injury when you use solvent cleaners, you must carefully follow the manufacturer's product instructions and these procedures:

- Wear safe eye protection.
 - Wear clothing that protects your skin.
 - Work in a well-ventilated area.
 - Do not use gasoline, or solvents that contain gasoline. Gasoline can explode.
 - You must use hot solution tanks or alkaline solutions correctly. Follow the manufacturer's instructions carefully.
1. Clean the ground and polished surface of the yoke journal using a clean shop towel and a safe cleaning solvent. Do not use gasoline, abrasive cleaners, towels, or scrubbers to clean the yoke. Do not attempt to polish the yoke.

NOTE

The unitized seal features a rubber inner sleeve that is designed to seal and rotate with the yoke. This feature allows you to reuse a yoke with minor grooves.

2. Inspect the yoke seal surface for grooves.
 - **If you find grooves on the yoke:** Use calipers to measure the groove diameters. If any groove diameter measures less than the dimensions shown in **Figure 5.34**, replace the yoke.

Figure 5.34

YOKE SEAL DIAMETER	MINIMUM YOKE DIAMETER AT GROOVE (INCHES)
3.000/3.005"	2.990"
3.250/3.255"	3.240"

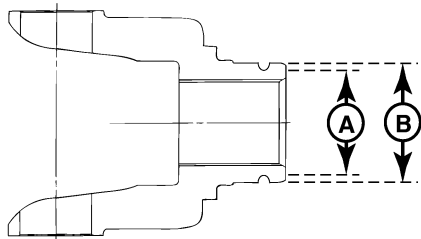

1003390a

- A** MINIMUM GROOVE DEPTH — DIAMETER
B YOKE SEAL DIAMETER

CAUTIONS

⚠ Do not install a POSE™ seal after you install a unitized pinion seal. The use of a POSE™ seal will prevent correct seating of the unitized pinion seal on the yoke and can result in lubricant leakage at the seal. POSE™ seal installation is recommended only for triple lip and other previous design seals.

⚠ Do not use thin metal wear sleeves to refresh the yoke surface. Wear sleeves pressed onto the yoke can prevent correct seating of the pinion seal, damage the pinion seal assembly and can cause the seal to leak.

3. Before you install the yoke, lightly lubricate or coat the yoke seal journal with axle oil.
4. Align the yoke splines with the shaft splines. Slide the yoke over the shaft spline.

⚠ CAUTION

Do not use a hammer or mallet to install the yoke to the input pinion shaft. Using a hammer or mallet can damage the yoke or flange.

5. Install the input yoke flange onto the drive pinion shaft. The yoke or flange must be fully seated against the outer differential bearing **before** the nut is torqued to specifications.
6. Install the drive pinion nut (and washer if required) on the input pinion shaft and against the yoke collar. Tighten the nut against yoke collar to torque specifications. **Figure 5.35**. Refer to **Table J**.

Figure 5.35

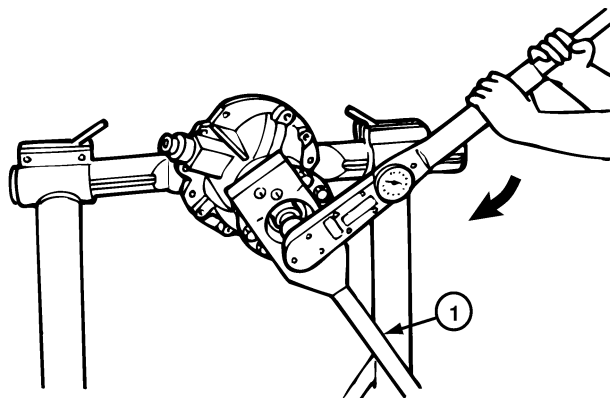

1003062a

- 1** USE FLANGE OR YOKE BAR

Section 5 Assembly

Assemble the Main Differential and Ring Gear Assembly

CAUTION

Do not press a cold ring gear on the flange case half. A cold ring gear will damage the case half because of the tight fit. Metal particles between the parts will cause gear runout that exceeds the RICO specification of 0.008 inch (0.2 mm).

1. Expand the ring gear by heating the gear in a tank of water to a temperature of 160°F to 180°F (71°C-82°C) for 10 to 15 minutes.

WARNING

Wear safe clothing and gloves for protection from injury when working with the hot ring gear.

2. Safely lift the ring gear from the tank of water using a lifting tool.
3. Install the ring gear on the flange case half immediately after the gear is heated. If the ring gear does not fit easily on the case half, heat the gear again. Repeat step 1.
4. Align fastener holes of the ring gear and flange case half. Rotate the ring gear as needed.
5. If rivets* were used to hold the ring gear to the flange case half, replace them with bolts, nuts and washers.
6. Install the bolts*, nuts* and washers* that hold the ring gear to the flange case half. Install the bolts from the gear side of the assembly. The bolt heads **must** be against the ring gear. **Figure 5.36.**

Figure 5.36

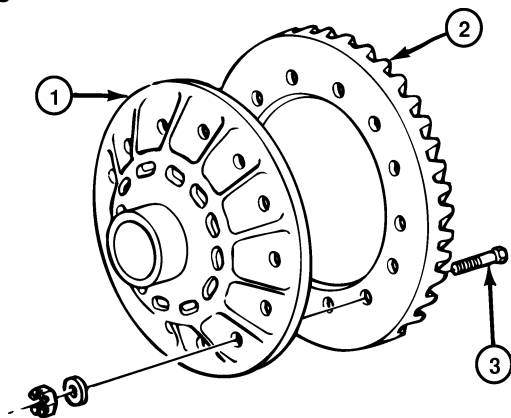

- 1 FLANGE CASE HALF
- 2 RING GEAR
- 3 BOLT HEAD AGAINST GEAR

7. Tighten the bolts* and nuts* to the correct torque value. Refer to **Table J.**
 - a. After the bolts are installed, check for gaps between the back surface of the ring gear and the case flange. Use an 0.08 mm (0.003 inch) feeler gauge and check at four points around the assembly. **Figure 5.37.**
 - b. Check the flange case half and ring gear for the problem that causes the gap. Repair or replace parts.
 - c. After the parts are repaired or replaced, assemble the ring gear on the flange case half. Repeat the procedure in "Installing Tight Fit Yokes and POSE™ Seal," and steps a through c.

Figure 5.37

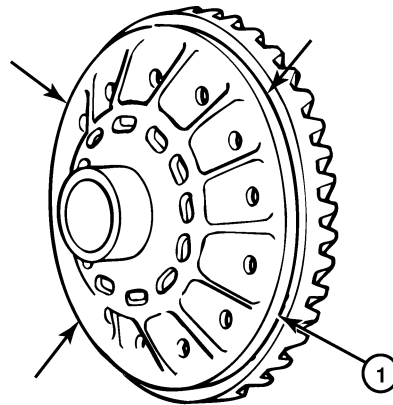

1003064a

- 1 CHECK FOR 0.003" GAP AT FOUR LOCATIONS

Section 5 Assembly

8. Install the bearing cones on both of the case halves. Use a press and sleeve of the correct size. **Figure 5.38.**

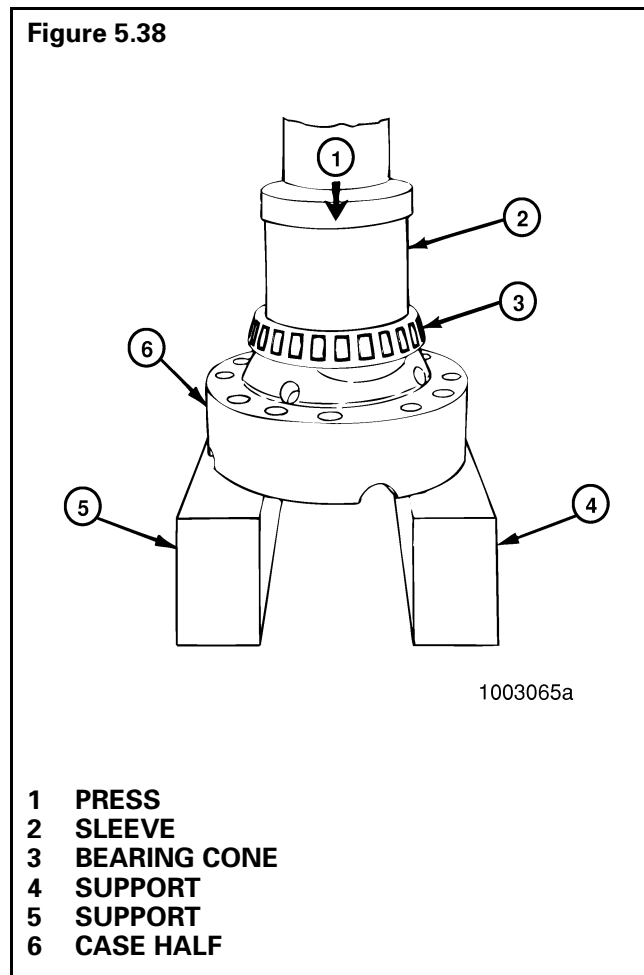

11. Install one thrust washer and side gear into the flange case half. **Figure 5.39.**

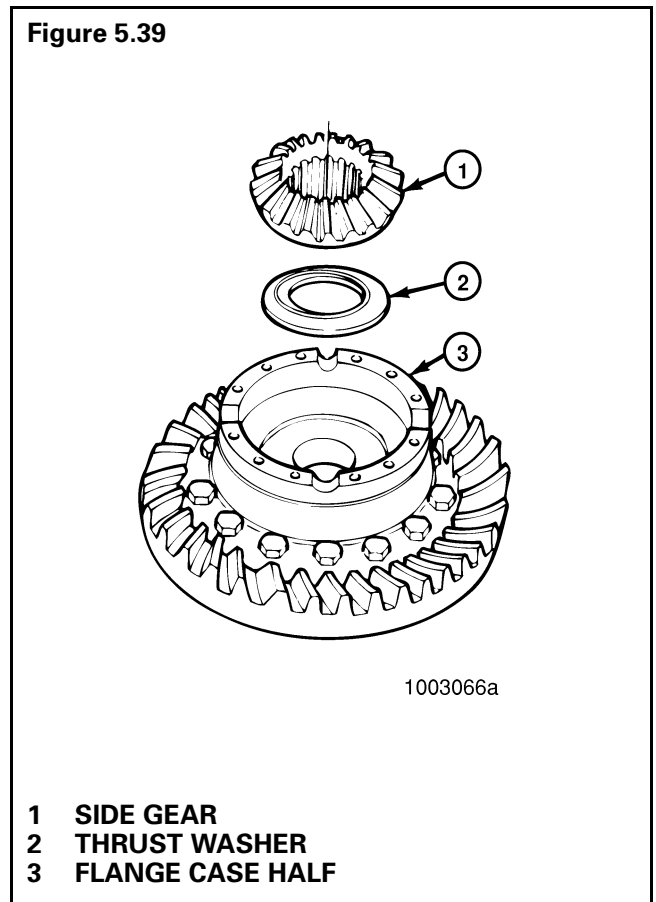

9. Apply axle lubricant on the inside surfaces of both case halves, spider (cross), thrust washers, side gears and differential pinions.
10. Place the flange case half on a bench, ring gear teeth toward top.

Section 5 Assembly

CAUTION

The side gears in some carrier models have hubs of different lengths. Install the correct length side gear into the flange case half.

12. Install the spider (cross), differential pinions and thrust washers into the flange case half. **Figure 5.40.**
13. Install the second side gear and thrust washer over spider and differential pinions. **Figure 5.41.**

Figure 5.40

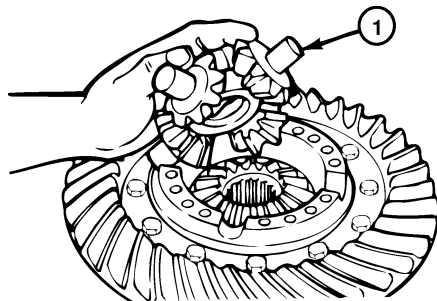

1003067a

- 1 SPIDER, PINION AND THRUST WASHERS

Figure 5.41

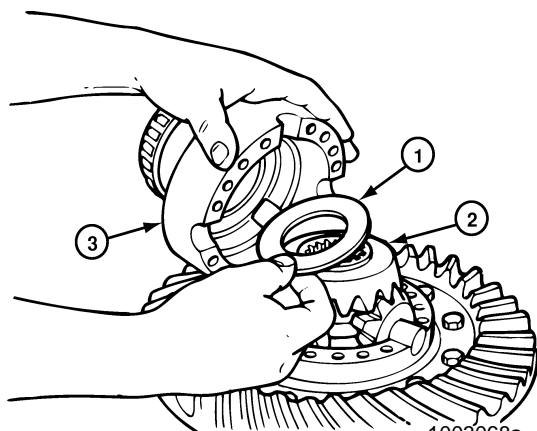

1003068a

- 1 THRUST WASHER
- 2 SIDE GEAR
- 3 PLAIN CASE HALF

14. Place the plain half of the differential case over the flange half and gears. Rotate the plain half as needed to align the match marks. **Figure 5.41 and Figure 5.42.**

Figure 5.42

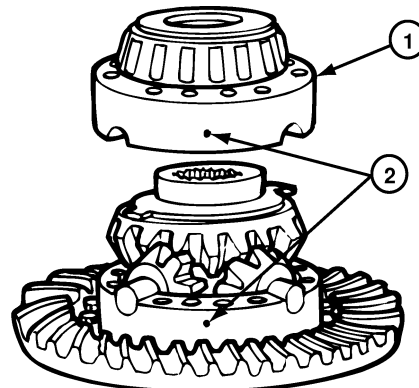

1003069a

- 1 PLAIN CASE HALF
- 2 MATCH MARKS

15. Install Dri-Loc fasteners into the case halves. Refer to "General Information" and the following steps **a** and **b**.
 - a. Install four capscrews* and washers* or bolts*, nuts* and washers* into the case halves. The distance between the fasteners **must** be equal. Tighten the fasteners to the correct torque value in a progressive criss-cross pattern opposite each other. Refer to **Figure 5.43** and **Table J**.
 - b. Install the other fasteners into the case halves. Tighten the fasteners to the correct torque value. Refer to **Table J**.
16. Check the rotating resistance of the differential gears. Use the following procedure.

Figure 5.43

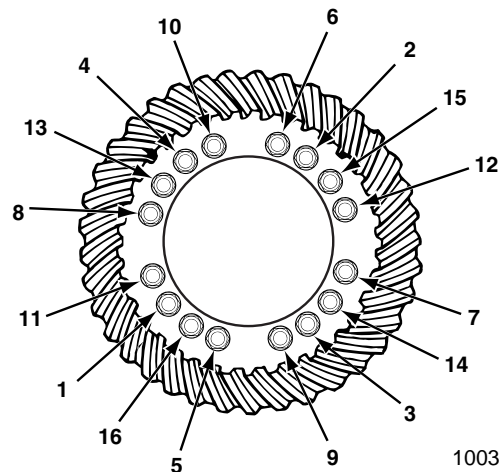

1003070a

Rotating Resistance Check of Differential Gears

Specification

- 50 lb-ft (67.8 N•m) maximum torque applied to one side gear. **1**

NOTE

Make a tool for checking the rotating resistance of the differential gears. The tool can be made from an axle shaft that matches the spline size of the differential side gear. Refer to Figure 5.44.

- Install soft metal covers over vise jaws to protect the ring gear. **Figure 5.45.**
- Place the differential and ring gear assembly in the vise.
- Install the tool into the differential until the splines of the tool and one side gear are engaged. **Figure 5.45.**

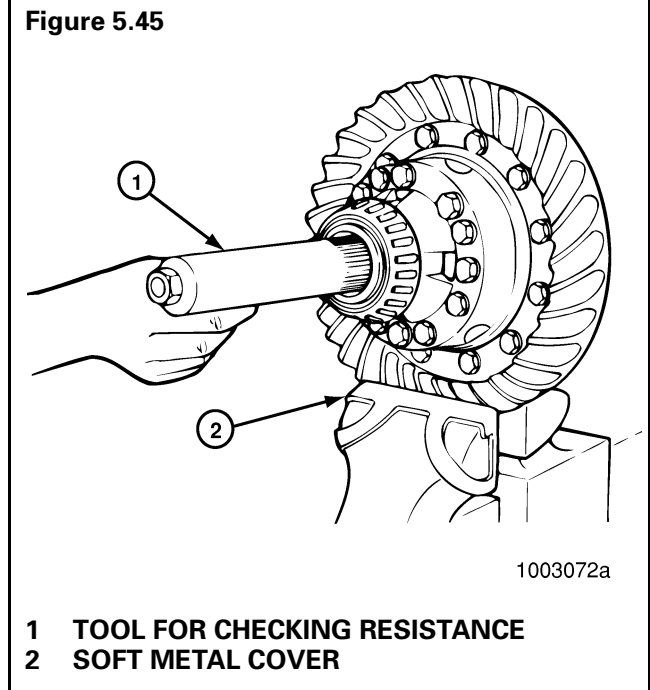
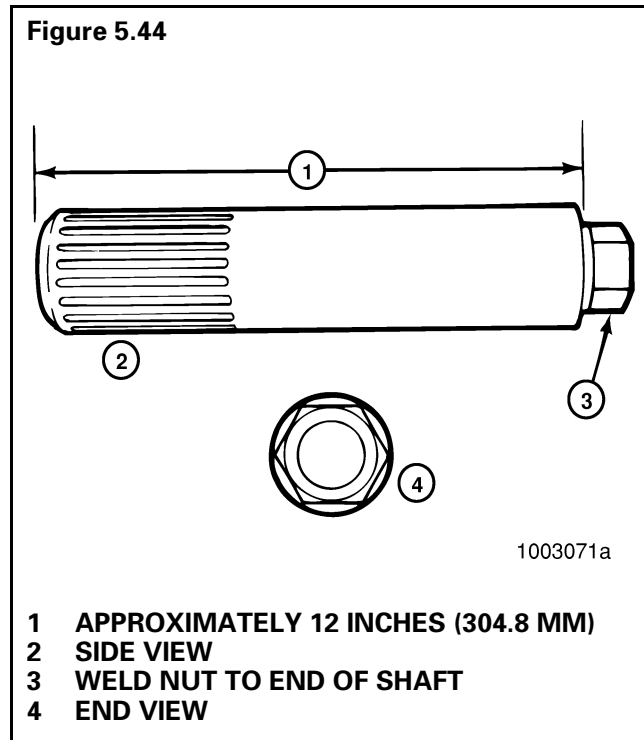

- Attach a torque wrench to the nut of the tool and rotate the differential gears. As the differential gears rotate, read the value indicated on the torque wrench. **Figure 5.46.**

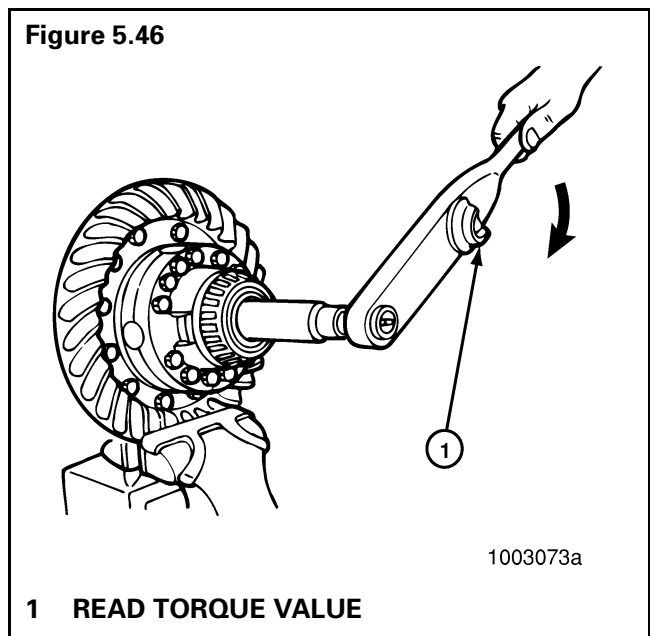

Section 5 Assembly

- e. If the torque value exceeds the specification, disassemble the differential gears from the case halves.
- f. Check the case halves, spider, gears and thrust washers for the problem that causes the torque value to exceed the specification. Repair or replace parts.

After the parts are repaired or replaced, assemble the parts and repeat steps a through f.

Install the Differential and Ring Gear Assembly

1. Clean and dry the bearing cups and bores of the carrier legs and bearing caps.
2. Apply axle lubricant on the inner diameter of the bearing cups and on both bearing cones that are assembled on the case halves.
3. Apply RICO Adhesive into the bearing bores of the carrier legs and bearing caps. Make certain not to allow adhesive to contact adjusting ring threads. Refer to "General Information." **Figure 5.47.**

Figure 5.47

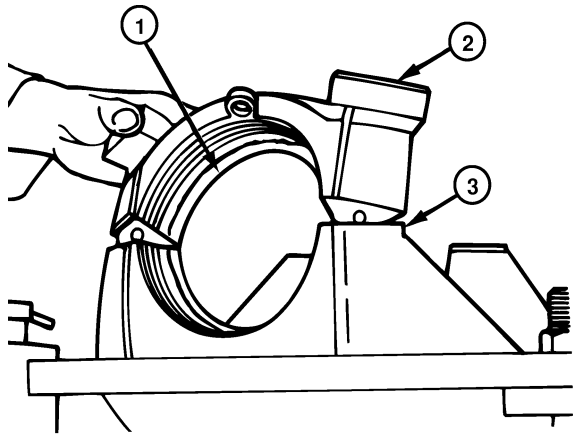

1003074a

- 1 ADHESIVE
- 2 BEARING CAP
- 3 CARRIER LEG

4. Install the bearing cups over the bearing cones that are assembled on the case halves. **Figure 5.48.**
5. Safely lift the differential and ring gear assembly and install into the carrier. The bearing cups **must** be flat against the bores between the carrier legs. **Figure 5.48.**

Figure 5.48

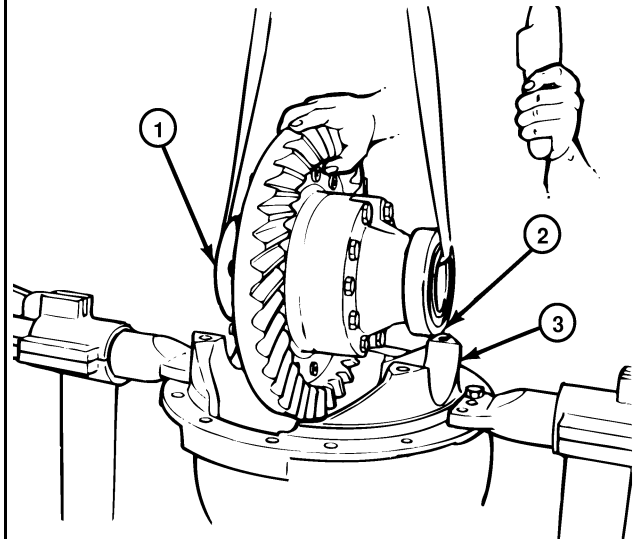

1003075a

- 1 BEARING CUP
- 2 BEARING CUP
- 3 LEG BORE

6. Install both of the bearing adjusting rings into position between the carrier legs. Turn each adjusting ring hand-tight against the bearing cup. **Figure 5.49.**

Figure 5.49

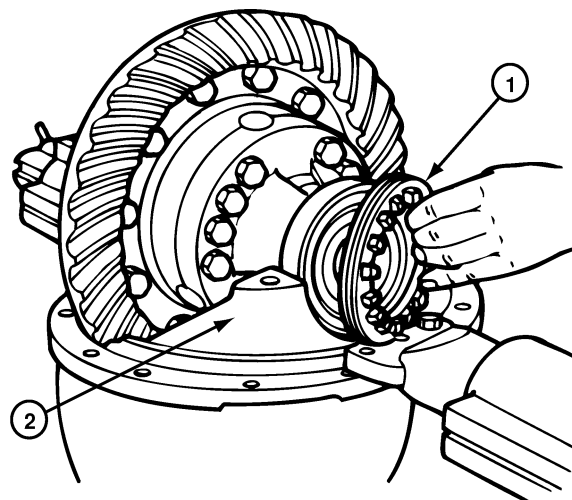

1003076a

- 1 ADJUSTING RING
- 2 LEG

7. Install the bearing caps over the bearings and adjusting rings in the correct location as marked before removal. **Figure 5.50.**

Figure 5.50

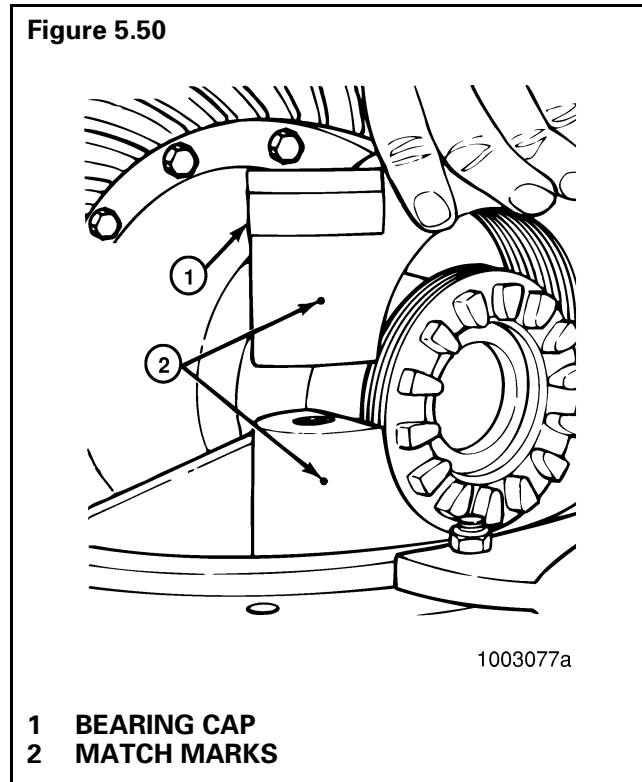

WARNING

Use a brass or leather mallet for assembly and disassembly procedures. Do not hit steel parts with a steel hammer. Pieces of a part can break off and cause serious personal injury.

8. Seat each bearing cap with a light leather, plastic or rubber mallet. The caps **must** fit easily against the bearings, adjusting rings and carrier. **Do not force the bearing caps into position.**

CAUTION

If bearing caps are not installed in correct locations, the bores and threads in caps will not match the carrier. You will have problems assembling the caps on the carrier and damage to parts can occur. Do not force the bearing caps into position.

9. If bearing caps do not correctly fit into position, check the alignment of match marks between caps and carrier. Remove the caps and repeat steps 6-8.

10. Install the capscrews and washers that hold bearing caps to the carrier. Tighten the capscrews by hand four to six turns, then tighten the capscrews to the correct torque value. Refer to **Table J.**

NOTE

Do not install the cotter keys, pins* or lock plates* that hold the bearing adjusting rings in position. Continue by adjusting the preload of differential bearings, adjust backlash of the hypoid gear and check tooth contact patterns.*

Adjust Preload of Differential Bearings

Specifications

- Preload of differential bearings (all carrier models)
 - 15 to 35 lb-in (1.7-3.9 N•m) torque. **T**
- Expansion between bearing caps (leg spread)
 - RS-140, RS-145 and RS-160 carrier models: 0.002 to 0.009 inch (0.05-0.229 mm)
 - RS 120 and all other carrier models: 0.006 to 0.013 inch (0.15-0.33 mm)

Method 1

1. Attach a dial indicator on the mounting flange of the carrier.
2. Adjust the dial indicator so that the plunger or pointer is against the back surface of the ring gear. **Figure 5.51.**

Figure 5.51

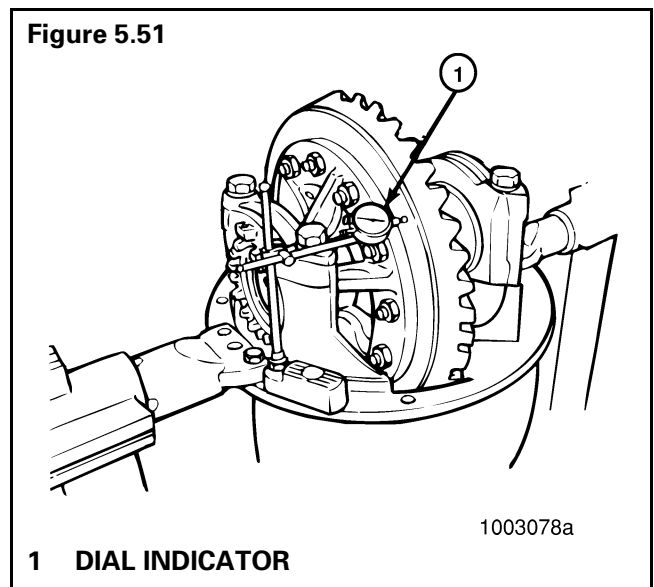

Section 5 Assembly

CAUTION

When you turn the adjusting rings, always use a tool that engages two or more opposite notches in the ring. A "T" bar wrench can be used for this purpose. If the tool does not correctly fit into the notches, damage to the lugs will occur. Figure 5.52.

3. Loosen the bearing adjusting ring that is opposite the ring gear so that a small amount of end play shows on the dial indicator. **Figure 5.52.** Move the differential and ring gear to the left and right with pry bars while you read the dial indicator. Use the following step a or b.
 - a. Use two pry bars that fit between the bearing adjusting rings and ends of the differential case. The pry bars **must not** touch the differential bearings. **Figure 5.53.**

Figure 5.52

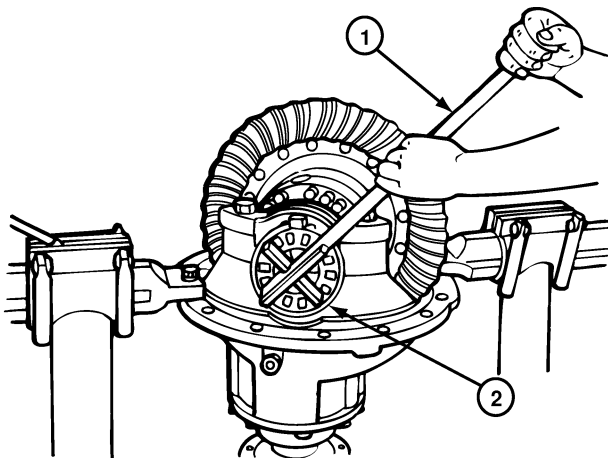

1003079a

- 1 "T" BAR WRENCH
- 2 ADJUSTING RING OPPOSITE RING GEAR

Figure 5.53

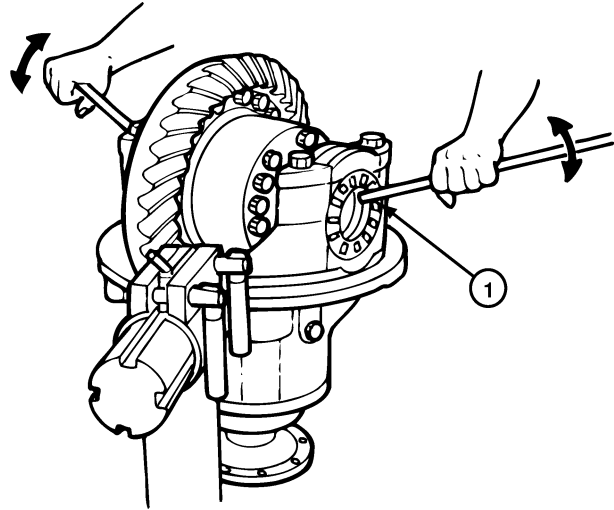

1003080a

- 1 BARS MUST NOT TOUCH BEARINGS

- b. Use two pry bars between the differential case or ring gear and the carrier at locations other than described in step a. The pry bars **must not** touch the differential bearings. **Figure 5.54.**

Figure 5.54

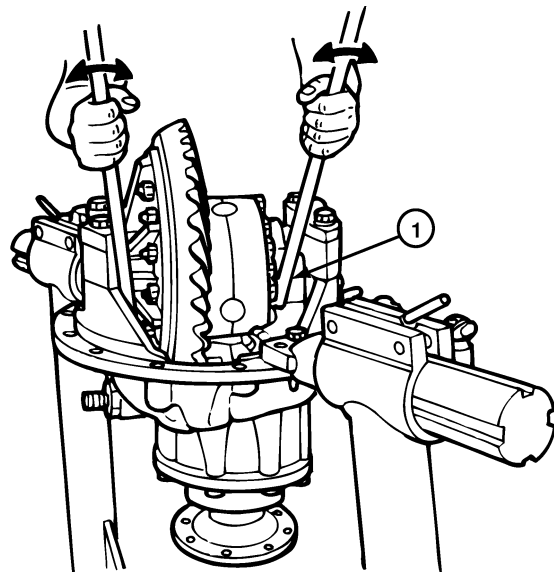

1003081a

- 1 BARS MUST NOT TOUCH BEARINGS

4. Tighten the same bearing adjusting ring so that no end play shows on the dial indicator. Move the differential and ring gear to the left and right as needed. Repeat step **a** or **b**.
5. Tighten each bearing adjusting ring one notch from the zero end play measured in step 4.
6. Continue by checking runout of the ring gear.

Method 2

A second method of checking preload is to measure the expansion between the bearing caps (leg spread) after the adjusting rings are tightened. Use the following procedure.

1. Turn both adjusting rings hand tight against the differential bearings.
2. Measure the distance X or Y between opposite surfaces of the bearing caps. Use a large micrometer of the correct size. **Figure 5.55** and **Figure 5.56**. Record the measurement.

Figure 5.55

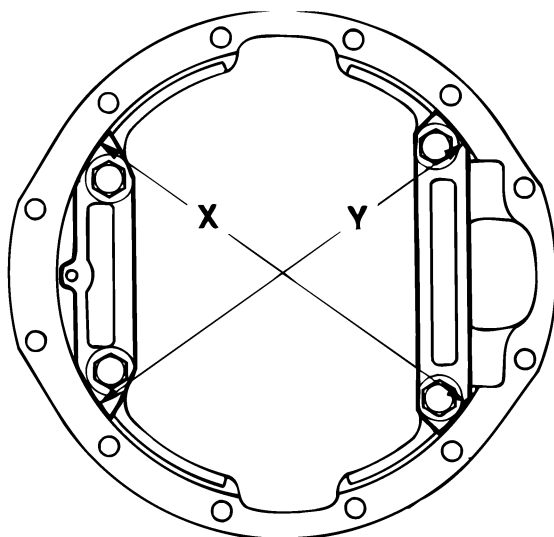

1003082a

Figure 5.56

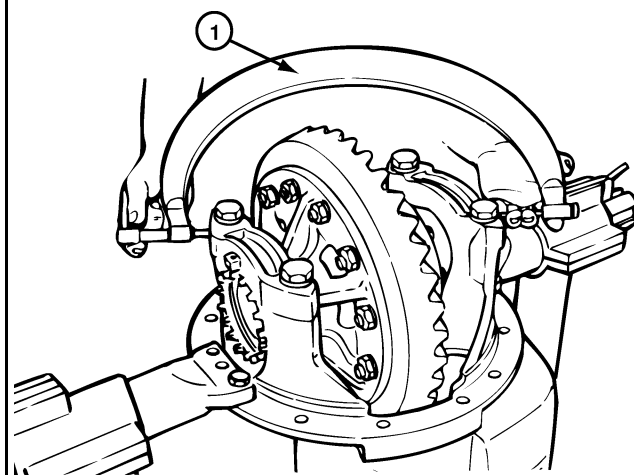

1003083a

1 MICROMETER

3. Tighten each bearing adjusting ring one notch.
4. Measure the distance X or Y again. Compare the dimension with the distance X or Y measured in step 2. The difference between the two dimensions is the amount the bearing caps have expanded.

Example

- Measurements of RS-145 carrier
- Distance X or Y
 - before tightening adjusting rings = 13.927 inch (353.74 mm).
- Distance X or Y
 - after tightening adjusting rings = 13.936 inch (353.97 mm)
- 13.936 inch — 13.927 inch = 0.009 inch (0.23 mm) difference.

If the dimension is within specifications, continue by checking runout of the ring gear. If the dimension is less than specifications, repeat steps 3 and 4 as needed.

Section 5 Assembly

Check Runout of Ring Gear

Runout Specification

- 0.008 inch (0.20 mm)

1. Attach a dial indicator on the mounting flange of the carrier. **Figure 5.57.**

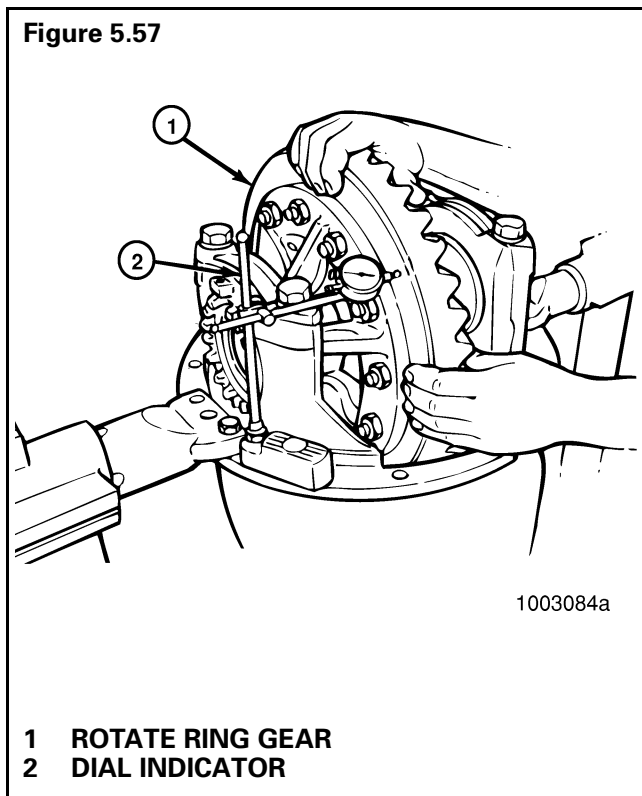

2. Adjust the dial indicator so that the plunger or pointer is against the back surface of the ring gear.
3. Set the dial indicator to zero (0).
4. Rotate the differential and ring gear and read the dial indicator. The runout of the ring gear **must not exceed** 0.008 inch (0.20 mm). **Figure 5.57.**

If runout of the ring gear exceeds specifications, remove the differential and ring gear assembly from the carrier. Refer to "Remove the Differential and Ring Gear from the Carrier" and the following steps 5 and 6.

5. Check the differential parts including the carrier for the problem that causes the runout of gear to exceed specifications. Repair or replace parts.

6. After the parts are repaired or replaced, install the differential and ring gear into the carrier. Refer to "Install the Differential and Ring Gear Assembly."
7. Repeat preload adjustment of differential bearings.

Ring Gear Backlash Adjustment

Specifications

- Ring gears that have a pitch diameter of less than 17 inches (431.8 mm)
 - Range of backlash setting: 0.008 to 0.018 inch (0.20-0.46 mm)
 - Backlash setting for new gear sets: 0.012 inch (0.30 mm)
- Ring gears that have a pitch diameter greater than 17 inches (431.8 mm)
 - Range of backlash setting: 0.010 to 0.020 inch (0.25-0.51 mm)
 - Backlash setting for new gear sets: 0.015 inch (0.38 mm)

NOTE

Measure the outer diameter of ring gear for approximate pitch diameter. Figure 5.58.

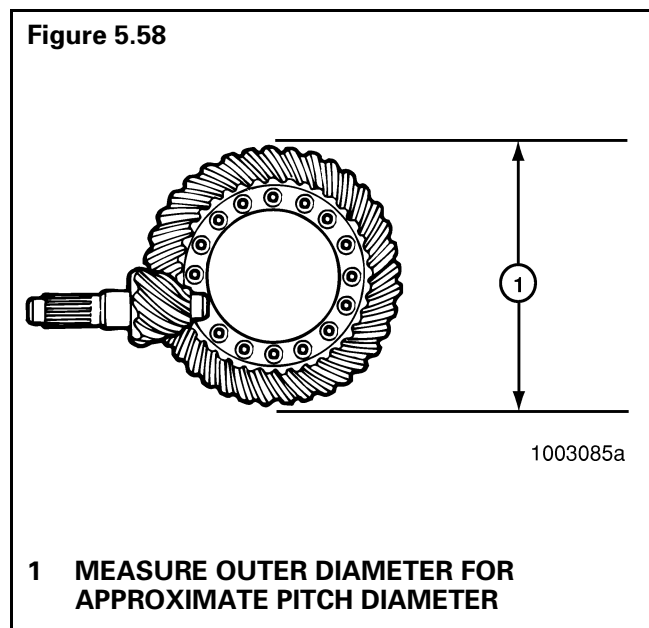

Section 5 Assembly

If the old gear set is installed, adjust the backlash to the setting that was measured before the carrier was disassembled.

If a new gear set is installed, adjust the backlash to the correct specification for new gear sets.

After checking of the tooth contact patterns, the backlash can be adjusted within specification limits, if needed. To change the location of the pattern use the following procedures.

1. Attach a dial indicator on the mounting flange of the carrier. **Figure 5.59.**

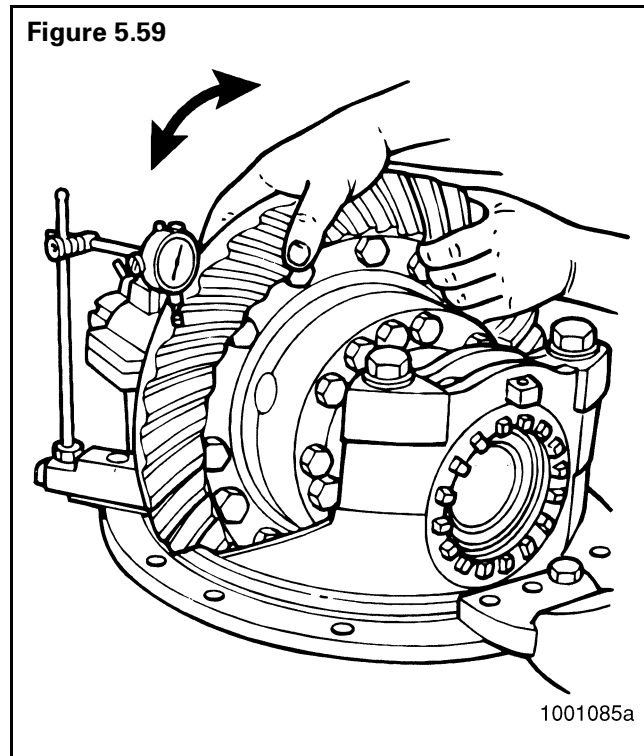

2. Adjust the dial indicator so that the plunger or pointer is against the tooth surface. **Figure 5.59.**
3. Adjust the indicator dial to zero (0).
4. Hold the drive pinion in position.
5. After reading the dial indicator, rotate the differential and ring gear a small amount in both directions, against the drive pinion teeth. If the backlash reading is within specification, continue checking tooth contact patterns. If the backlash reading is not within specifications, adjust backlash as needed. Continue following steps 6 and 7.

Figure 5.60

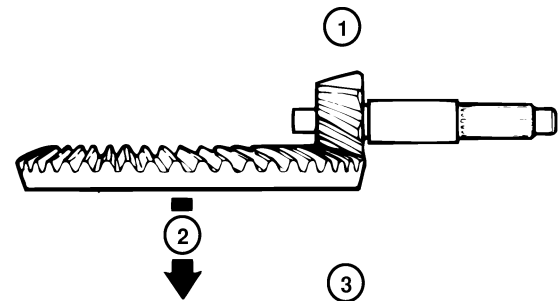

1003087a

- 1 TIGHTEN ADJUSTING RING THIS SIDE
- 2 INCREASE BACKLASH
- 3 LOOSEN ADJUSTING RING THIS SIDE

NOTES

- Backlash is increased by moving the ring gear away from the drive pinion. **Figure 5.60.**
 - Backlash is decreased by moving the ring gear toward the drive pinion. **Figure 5.61.**
6. Loosen one bearing adjusting ring one notch then tighten the opposite ring the same amount. Refer to **Figure 5.60** and **Figure 5.61.**

NOTE

When you adjust backlash, move the ring gear ONLY. DO NOT move the drive pinion.

7. Repeat steps 2-6 until the backlash is within specifications.

Figure 5.61

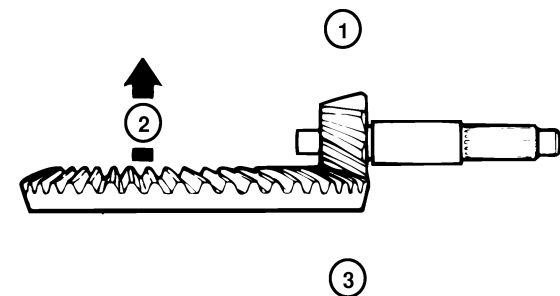

1003088a

- 1 LOOSEN ADJUSTING RING THIS SIDE
- 2 DECREASE BACKLASH
- 3 TIGHTEN ADJUSTING RING THIS SIDE

Section 5 Assembly

Checking Tooth Contact Patterns (Backlash) of the Gear Set

General Information

RICO carriers can have a *generoid* hypoid gear set. The tooth contact patterns for each type of gear set are different. Look at the part numbers to see what type of gear set is in the carrier. Refer to **Figure 5.62** for the location of part numbers.

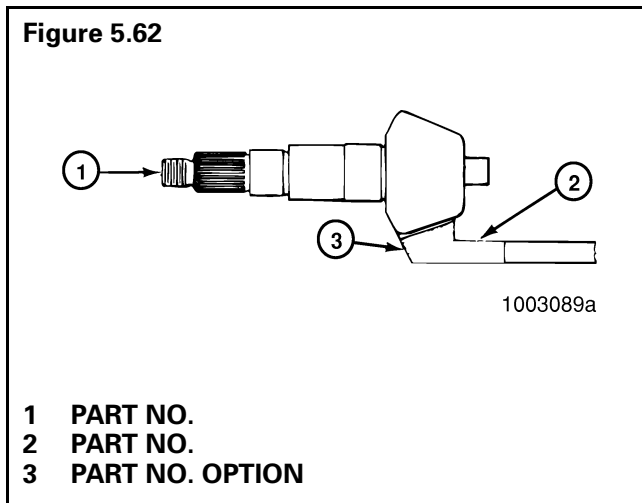

Examples

Part numbers for *generoid* gear sets

- 36786-K or 36786-K2 for the ring gear
- 36787-K or 36787-K2 for the drive pinion

In the following procedures, movement of the contact pattern in the length of the tooth is indicated as toward the “heel” or “toe” of the ring gear. **Figure 5.63.**

Always check tooth contact patterns on the drive side of the gear teeth. **Figure 5.64.**

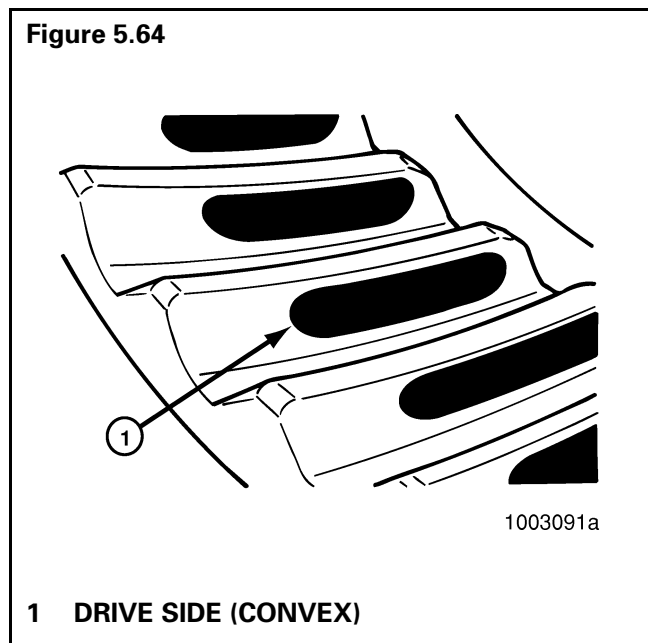
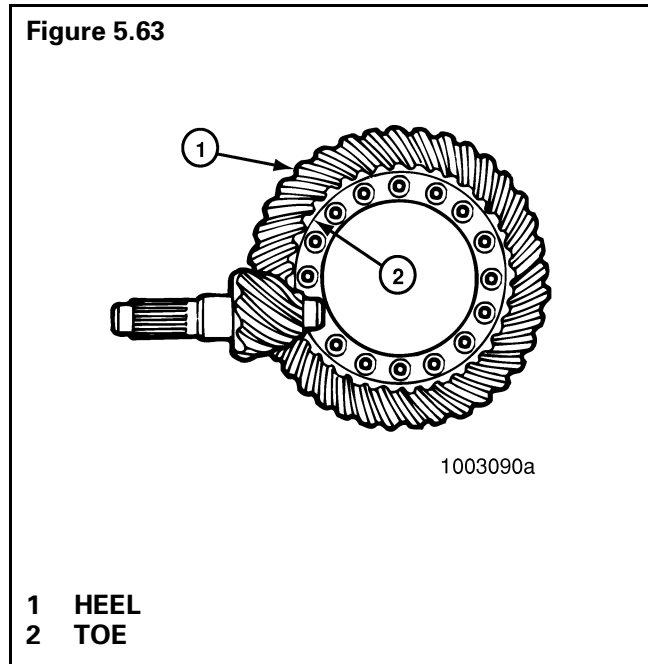

Tooth Contact Patterns of Generoid Hypoid Gear Sets

1. Adjust the backlash of a new gear set to either 0.012 inch (0.305 mm) or 0.015 inch (0.380 mm) depending on the size of the ring gear. Adjust the backlash of an old gear set to the setting that was measured before the carrier was disassembled. Refer to "Ring Gear Backlash Adjustment."
2. Apply a marking compound to approximately 12 gear teeth of the ring gear. Rotate the ring gear so that the 12 gear teeth are next to the drive pinion. **Figure 5.65.**

Figure 5.65

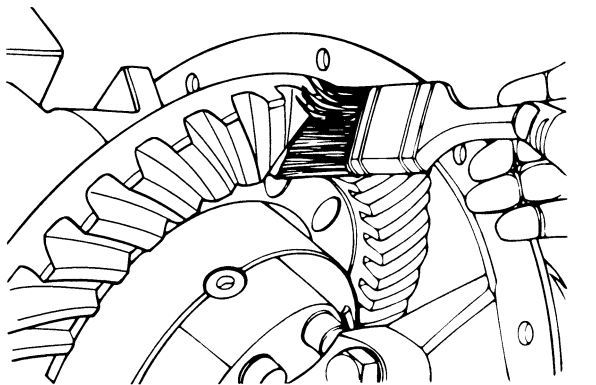

3. Rotate ring gear forward and backward so that the 12 gear teeth go past the drive pinion six times to get the contact patterns. Repeat if needed to get a more clear pattern.

Hypoid Generoid Gears

Figure 5.66

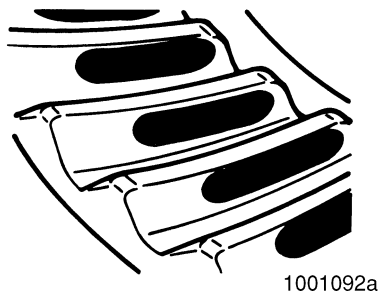

Good Hand-Rolled Pattern

Figure 5.67

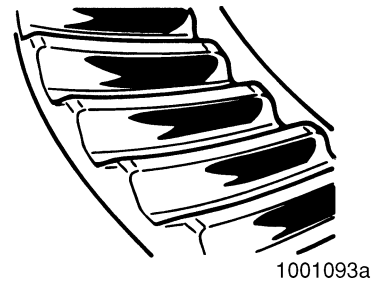

High Pattern

Figure 5.68

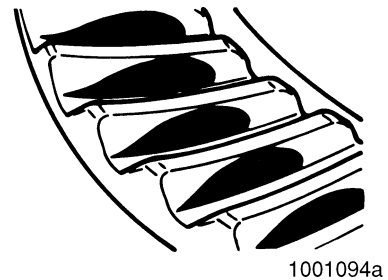

Low Pattern

4. Look at the contact patterns on the ring gear teeth. Compare the patterns to **Figure 5.66**, **Figure 5.67** and **Figure 5.68**.

The Location of Good Hand-Rolled Contact Patterns

New Conventional and Generoid Gear Sets — toward the toe of the gear tooth and in the center between the top and bottom of the tooth. Refer to **Figure 5.66**.

When the carrier is operated, a good pattern will extend approximately the full length of the gear tooth. The top of the pattern will be near the top of the gear tooth. Refer to **Figure 5.69**.

The location of a good hand-rolled contact pattern for an old gear set **must** match the wear pattern in the ring gear. The new contact pattern will be smaller in area than the old wear pattern.

Section 5 Assembly

If the contact patterns require adjustment, continue by following step 5 to move the contact patterns between the top and bottom of the gear teeth. If the contact patterns are in the center of the gear teeth, continue by following step 6.

Figure 5.69

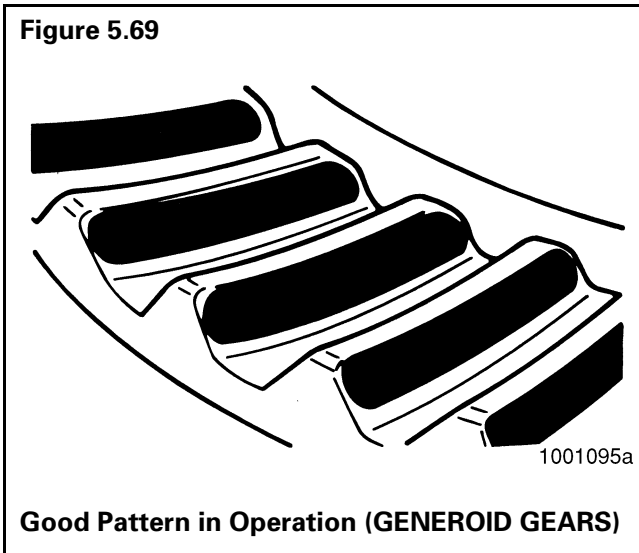

NOTE

A high contact pattern indicates that the drive pinion was not installed deep enough into the carrier. A low contact pattern indicates that the drive pinion was installed too deep in the carrier.

5. Change the thickness of the shim pack under bearing cage to move the contact patterns between the top and bottom of the gear teeth. Use the following procedure.
 - a. Remove the drive pinion and bearing cage from the carrier. Refer to "Remove the Drive Pinion and Bearing Cage from Carrier."
 - b. To correct a high contact pattern, **Figure 5.67** decrease the thickness of the shim pack under the bearing cage. When decreasing the thickness of the shim pack, the drive pinion will move toward the ring gear. **Figure 5.70**.

To correct a low contact pattern, **Figure 5.71** increase the thickness of shim pack under the bearing cage. When increasing the thickness of the shim pack, the drive pinion will move away from the ring gear. **Figure 5.71**.

Figure 5.70



1 DECREASE SHIM PACK

Figure 5.71



1 INCREASE SHIM PACK

- c. Install the drive pinion, bearing cage and shims into the carrier. Refer to "Adjusting Shim Pack Thickness for the Pinion Cage (Depth of Pinion)."
- d. Repeat steps 2-5 until the contact patterns are in the center between the top and bottom of the gear teeth.

Section 5 Assembly

6. Adjust backlash of the ring gear within specification range to move the contact patterns to the correct location in the length of the gear teeth. Refer to "Ring Gear Backlash Adjustment."
 - a. Decrease backlash to move the contact patterns toward the toe of the ring gear teeth. **Figure 5.72.**
 - b. Increase backlash to move the contact patterns toward the heel of the ring gear teeth. **Figure 5.73.**

Figure 5.72

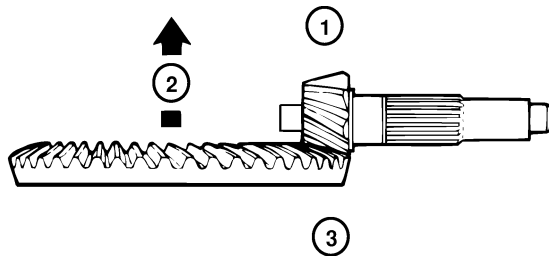

1003103a

- 1 MOVE PATTERN TOWARD TOE, LOOSEN ADJUSTING RING THIS SIDE
- 2 DECREASE BACKLASH
- 3 TIGHTEN ADJUSTING RING

Figure 5.73

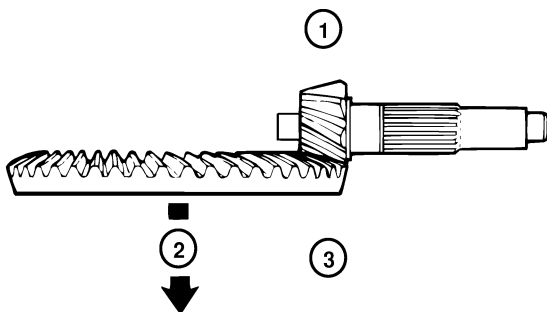

1003104a

- 1 MOVE PATTERN TOWARD TOE, LOOSEN ADJUSTING RING THIS SIDE
- 2 DECREASE BACKLASH
- 3 LOOSEN ADJUSTING RING

- c. Repeat steps 2-4 and 6 until the contact patterns are at the correct location in the length of the gear teeth.



CAUTION

If the carrier has cotter keys, lock the adjusting rings only with cotter keys. If your carrier has roll pins, reuse the roll pins or lock the adjusting rings with cotter keys. Do not force a roll pin into a cotter key hole.

7. Install cotter keys*, pins*, or lock plates* that hold the two bearing adjusting rings in position. Use the following procedures.
 - a. **Cotter Keys*** — Install cotter keys between lugs of the adjusting ring and through the boss of the bearing cap. Bend the two ends of the cotter key around the boss. **Figure 5.74.**
 - b. **Pins*** — Install pin through boss of the bearing cap until the pin is between lugs of the adjusting ring. Use a drift and hammer to install the pin. **Figure 5.74.**
 - c. **Lock Plates*** — Install lock plate on bearing cap so that the tab is between lugs of the adjusting ring. Install the two capscrews that hold the lock plate to the bearing cap. Tighten the capscrews to correct torque value. Refer to **Table J. Figure 5.74.**

Figure 5.74

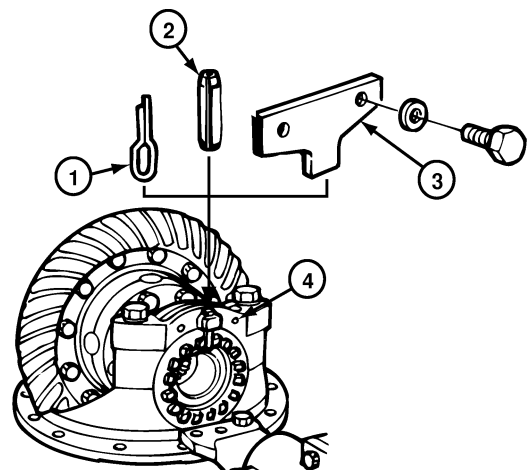

1003105a

- 1 COTTER KEY
- 2 PIN
- 3 LOCK PLATE
- 4 THREADED HOLES IN CAP WHEN LOCK PLATE IS USED

Section 5 Assembly

Install and Adjust the Thrust Screw*

Specification

- Clearance between thrust screw and ring gear — 0.025 to 0.045 inch (0.65-1.14 mm).
 - Loosen the thrust screw 1/2 turn or 180°.
1. Rotate the carrier in the repair stand until the back surface of ring gear is toward the top.
 2. Install the jam nut* on the thrust screw*, one half the distance between both ends. **Figure 5.75.**
 3. Loosen the thrust screw* 1/2 turn, 180°. **Figure 5.76.**

Figure 5.75

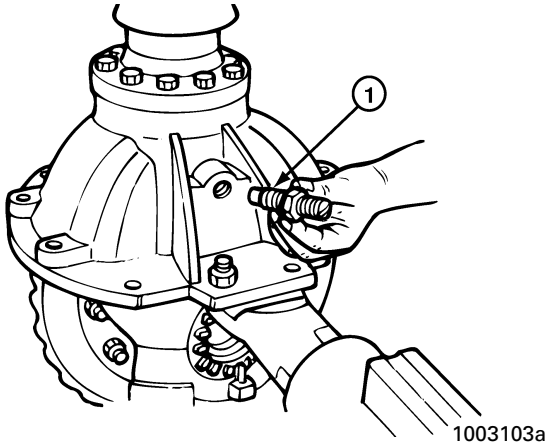

1 THRUST SCREW AND JAM NUT

Figure 5.76

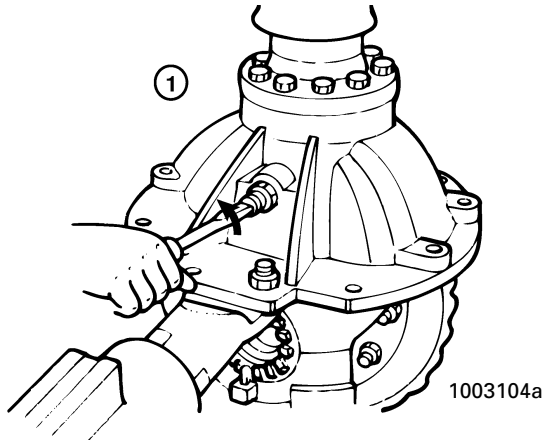

1 LOOSEN THRUST SCREW 1/2 TURN

4. Tighten the jam nut* to the correct torque value against the carrier. Refer to **Table J. Figure 5.77.**

Figure 5.77

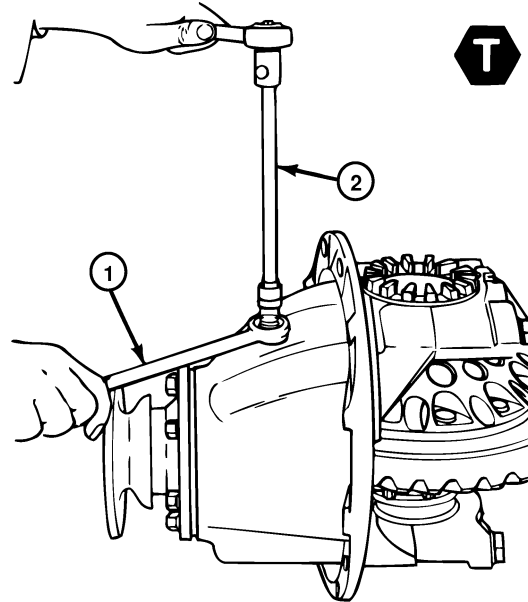

- 1 HOLD THRUST SCREW IN POSITION
- 2 TIGHTEN JAM NUT TO CORRECT TORQUE VALUE

NOTE

To complete the assembly of axles equipped with driver-controlled main differential locks, refer to "Installation of the DCDL Assembly into Carrier" through "Traction Control Video Package." Start with "Installation of the DCDL Assembly into Carrier."

Install Differential Carrier into Axle Housing

WARNING

Solvent cleaners can be flammable, poisonous and cause burns. Examples of solvent cleaners are carbon tetrachloride, emulsion-type cleaners and petroleum-based cleaners. To avoid serious personal injury when you use solvent cleaners, you must carefully follow the manufacturer's product instructions and these procedures:

- *Wear safe eye protection.*
- *Wear clothing that protects your skin.*
- *Work in a well-ventilated area.*
- *Do not use gasoline, or solvents that contain gasoline. Gasoline can explode.*
- *You must use hot solution tanks or alkaline solutions correctly. Follow the manufacturer's instructions carefully.*

1. Clean the inside of axle housing and the mounting surface where the carrier fastens. Use a cleaning solvent and rags to remove dirt. Blow dry the cleaned areas with air. Also refer to "Cleaning Axle Assemblies."
2. Inspect the axle housing for damage. Repair or replace the axle housing. Refer to "Repair or Replacement of Parts, General," "Repair Axle by Welding" and "Bending or Straightening Drive Axle Housings."
3. Check for loose studs* in the mounting surface of the housing where the carrier fastens. Remove and clean the studs* that are loose.
4. Apply liquid adhesive to the threaded holes and install the studs* into axle housing. Refer to "Application of RICO Adhesive 2297-T-4180 in Bearing Bores for the Differential." Tighten studs* to correct torque value. Refer to **Table J**. 
5. Apply silicone gasket material to the mounting surface of the housing where the carrier fastens. Refer to "Application of Three Bond 1216 or Equivalent Silicone Gasket Material." **Figure 5.78.**

Figure 5.78



1003110a

- 1 1/8" (3.2 MM) DIA. SILICONE GASKET BEAD**

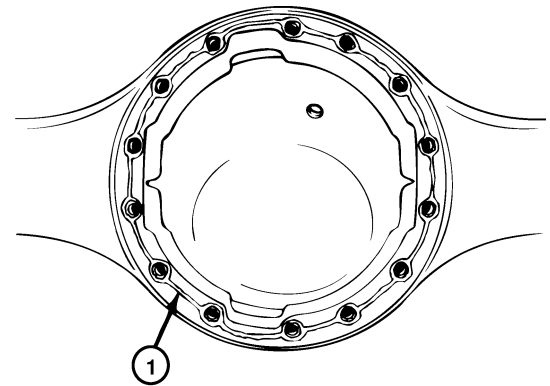
6. Install the carrier into the axle housing. Use a hydraulic roller jack or a lifting tool.

CAUTION

Do not install the carriers using a hammer or mallet. A hammer or mallet will damage the mounting flange of carrier and cause oil leaks.

7. Install nuts* and washers or capscrews and washers in the four corner locations around the carrier and axle housing. Tighten the fasteners hand tight at this time. **Figure 5.79.**
8. Carefully push the carrier into position. Tighten the four fasteners two or three turns each in a pattern opposite each other. Refer to **Figure 5.79.**

Figure 5.79

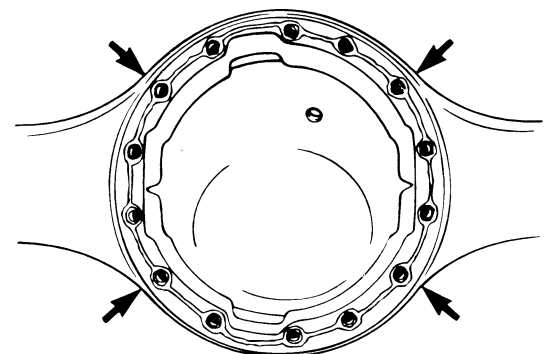

1001105a

Section 5 Assembly

9. Repeat step 8 until the four fasteners are tightened to the correct torque value. Refer to **Table J**.
10. Install the other fasteners and washers that hold the carrier in the axle housing. Tighten fasteners to the correct torque value. Refer to **Table J**.
11. Connect the driveline universal joint to the pinion input yoke or flange on the carrier.
12. Install the gaskets and axle shafts into the axle housing and carrier. The gasket and flange of the axle shafts **must** fit flat against the wheel hub. **Figure 5.80**.

Straight Holes, Nuts and Hardened Washers

1. Clean the mating surfaces of the axle shaft and the wheel hub.
2. If silicone gasket material is used, apply a 1/8-inch diameter bead of the gasket material around the mating surface of the hub and around the edge of each fastener hole in that surface.
3. Install the gasket and the axle shaft into the housing. The gasket and the flange of the axle shaft **MUST** fit flat against the wheel hub. Refer to **Figure 5.80**.
4. Install the Grade 8 nuts and hardened washers on the stud. (Lock washers are an acceptable alternative.) Tighten the stud nuts to the torque specified in **Table E**.

Table E — Shaft-to-Hub Torque Fastener Chart — Non-tapered Dowel Applications

Fastener	Thread Size	Torque Value — Grade 8 Nuts lb-ft (N·m)	
		Plain Nut	Lock Nut
Stud Nut (Axle Shaft)	62-18	150-230 (244-312)	130-190 (203-258)
	.75-16	310-400 (420-542)	270-350 (366-475)
Studs	All	Install the course thread end of stud into hub and tighten to last thread.	

Tapered Dowel, Hardened Washer and Hardened Nut

1. Clean the mating surfaces of the axle shaft and the wheel hub.
2. If silicone gasket material is used, apply a 1/8-inch diameter bead of the gasket material around the mating surface of the hub and around the edge of each fastener hole in that surface.
3. Install the gasket and the axle shaft into the housing. The gasket and the flange of the axle shaft **MUST** fit flat against the wheel hub. Refer to **Figure 5.80**.
4. Install solid tapered dowels over each stud and into the flange of the axle shaft. Use a punch or a drift and hammer, if necessary.
5. Install the Grade 8 nuts and hardened washers on the stud. (Lock washers are an acceptable alternative.) Tighten the stud nuts to the torque specified in **Table F**.

Figure 5.80

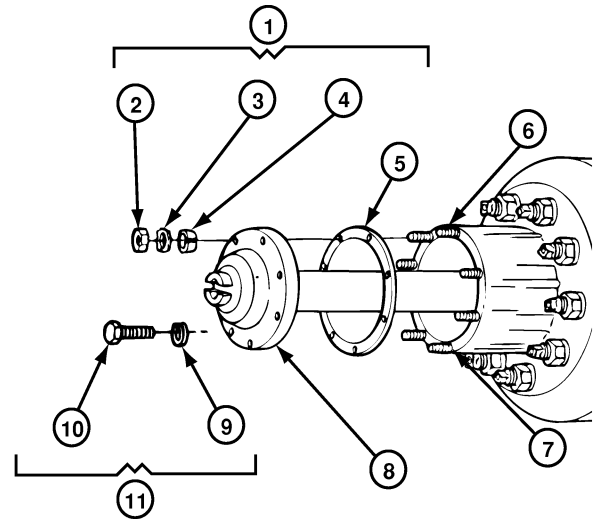

1003112a

- 1 TAPERED DOWEL RETENTION
- 2 STUD NUT
- 3 WASHER
- 4 TAPERED DOWEL
- 5 GASKET
- 6 STUD
- 7 SHAFT HUB AXLE
- 8 AXLE SHAFT (FLANGE)
- 9 WASHER
- 10 CAPSCREW
- 11 NON-TAPERED DOWEL RETENTION

Table F — Shaft-to-Hub Torque Fastener Chart — Tapered Dowel Applications

Fastener	Thread Size	Torque Value — Grade 8 Nuts lb-ft (N·m)	
		Plain Nut	Lock Nut
Stud Nut (Axle Shaft)	.44-20	50-75 (81-102)	40-65 (67-88)
	.50-20	75-115 (115-156)	65-100 (102-136)
	.56-18	110-165 (176-224)	100-145 (149-197)
	.62-18	150-230 (244-312)	130-190 (203-258)
Studs	All	Install the course thread end of stud into hub and tighten to last thread.	

Section 6

Driver-Controlled Main Differential Lock

Driver-Controlled Main Differential Lock Assembly

Figure 6.1

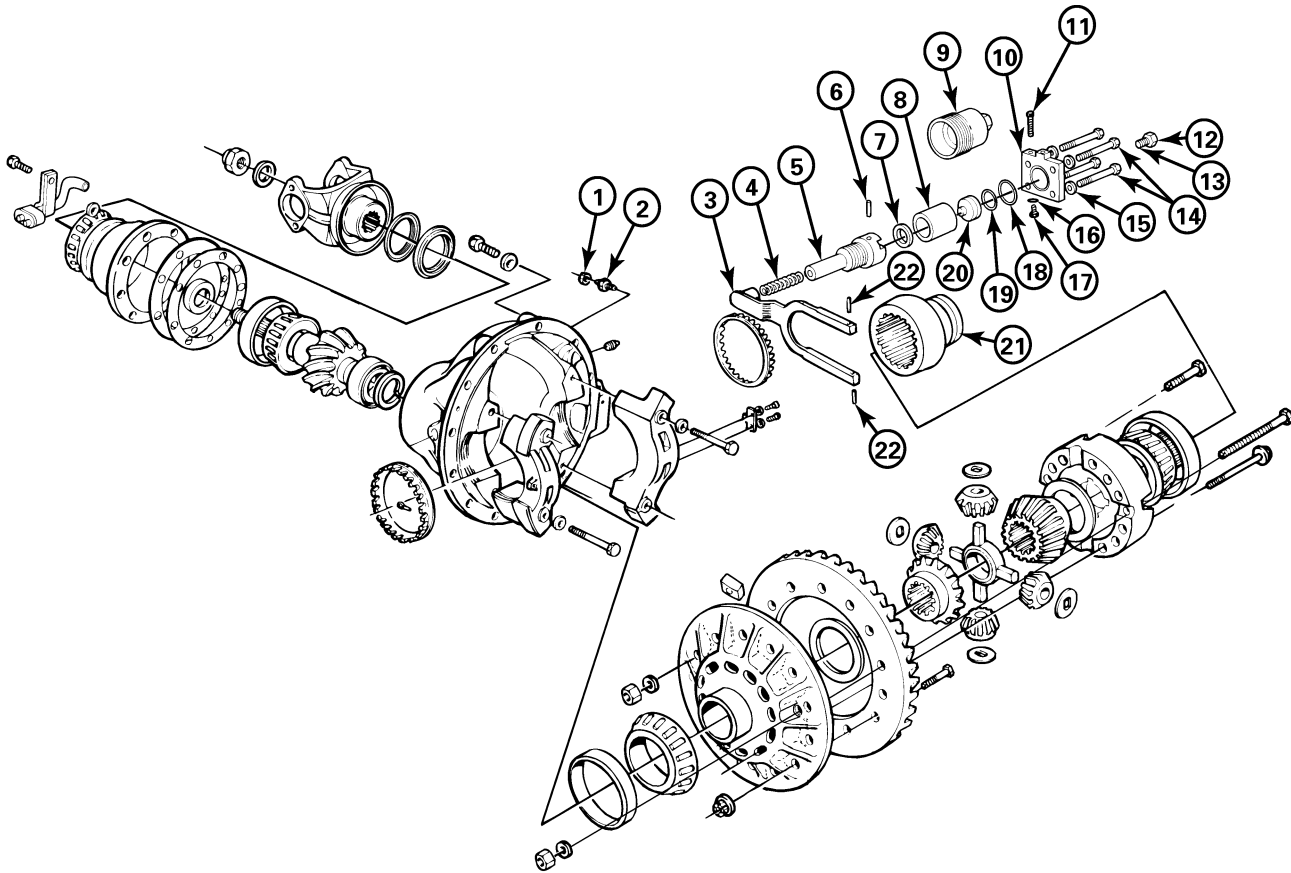

1001107a

- 1 LOCK NUT — SENSOR SWITCH
- 2 SENSOR SWITCH
- 3 SHIFT FORK
- 4 SHIFT SHAFT SPRING
- 5 SHIFT SHAFT
- 6 SPRING RETAINING PIN
- 7 FLAT WASHER (OR SILASTIC AS REQUIRED)
- 8 AIR CYLINDER TUBE
- 9 SCREW-IN DIFFERENTIAL LOCK
- 10 CYLINDER COVER
- 11 CAPSCREW — MANUAL ACTUATION (STORAGE POSITION)
- 12 WASHER (OPERATING POSITION)
- 13 PLUG GASKET (OPERATING POSITION)
- 14 COVER CAPSCREWS
- 15 WASHERS
- 16 PLUG GASKET (STORAGE POSITION)
- 17 COVER PLUG (STORAGE POSITION)
- 18 COVER COPPER GASKET
- 19 PISTON O-RING
- 20 PISTON
- 21 SHIFT COLLAR
- 22 SHIFT FORK ROLL PINS

Section 6

Driver-Controlled Main Differential Lock

Some RICO drive axle models have a DCDL or a driver-controlled main differential lock. This differential lock is operated by a carrier-mounted, air-actuated shift unit. When activated, the shift unit moves a sliding collar which is installed on the splines of the axle shaft. When engaged, the collar locks the axle shafts together with a second set of splines on the differential case. When the DCDL is engaged, there is no differential action. **Figure 6.1.**

NOTE

The RICO carrier models with driver-controlled differential lock equipment are manufactured in metric dimensions and sizes. When these carriers are serviced, it is important to use the correct metric size tools on the fasteners. Refer to the metric Table J, at the back of this manual.



CAUTION

If the vehicle must be towed to a service facility with the drive axle wheels on the ground, it is necessary to remove the axle shafts before the vehicle is towed, or internal axle damage will result.

1. Remove the axle shafts before the vehicle is towed. Refer to "Vehicle Towing Instructions."
2. Install the axle shafts after the vehicle is towed. Refer to "Vehicle Towing Instructions."
3. If the differential carrier must be removed from the axle housing, use the following procedures.

Removing the Differential Carrier from Axle Housing

Before the differential carrier can be removed or installed, the differential lock **must** be shifted into and held in the locked (engaged) position. The locked position gives enough clearance between the shift collar and the axle housing to permit the removal or installation of the carrier.

NOTE

If the axle shafts were removed for towing with the differential in the unlocked (disengaged) position, install the right-hand axle shaft into the housing before removing the differential carrier. Follow the procedures in "Vehicle Towing Instructions," starting with "After Towing or Drive-Away."

To shift into the locked position, use the "Manual Engaging" methods.

Axle Setup for DCDL Disassembly

1. Remove the drain plug from the bottom of the housing and drain the lubricant.
2. Raise the right-hand wheel of the drive axle off the floor with a hoist or jack.



WARNING

During DCDL disassembly, when the DCDL is in the locked (engaged) position and one of the vehicle's wheels is raised from the floor, do not start the engine and engage the transmission. The vehicle can move and cause serious personal injury.

3. Place a jack stand under the right-hand spring seat to hold the vehicle in the raised position.



WARNING

Block the wheels to prevent the vehicle from moving. Support the vehicle with safety stands. Do not work under a vehicle supported only by jacks. Jacks can slip and fall over. Serious personal injury can result.

4. Disconnect the driveline from the pinion input yoke.
5. Disconnect the vehicle air line from the differential lock actuator assembly.

Section 6

Driver-Controlled Main Differential Lock

DCDL Assembly Manual Engaging Methods

Bolt-On Style Differential Lock Cylinder

Use the following manual engaging method to lock out the bolt-on DCDL assembly. **Figure 6.2.**

1. Follow steps 1-5 of "Axle Setup for DCDL Disassembly."
2. Remove the plug and gasket from the hole in the center of the cylinder cover.
3. Remove the manual engaging cap screw from the top storage hole in the cylinder cover.

4. Install the plug and gasket into the bottom storage hole in the cylinder cover.

NOTE

The storage hole for the plug and gasket is located on the opposite side of the cylinder cover where the storage hole for the manual engaging capscrew is located.

5. Install the manual engaging capscrew into the threaded hole in the center of the cylinder cover.
6. Turn the manual adjusting capscrew to the right until the head is approximately 1/4 to 1/2 inch from the cylinder cover. **Do not** turn the capscrew beyond its normal stop. If the 1/4 to 1/2 service position of the capscrew is achieved, the main differential lock is completely engaged.

CAUTION

There will be a small amount of spring resistance felt when you turn in the manual engaging capscrew. If a high resistance is felt before reaching the locked (engaged) position, STOP TURNING THE CAPSCREW, or the cover and capscrew threads will be damaged.

A high resistance on the capscrew indicates that the splines of the shift collar and the differential case half are not aligned or engaged. To align the splines use the following procedure:

- a. Rotate the drive pinion or right-hand wheel to align the splines of the shift collar and case half while you turn in the manual engaging capscrew.
 - b. When a normal amount of spring resistance is felt on the capscrew, the splines are engaged. Continue to turn in the manual engaging capscrew until the head is approximately 1/4 inch from the cylinder cover.
7. Remove the carrier from the axle housing as described in steps 1-7 of "Carrier Removal from Axle."

Figure 6.2

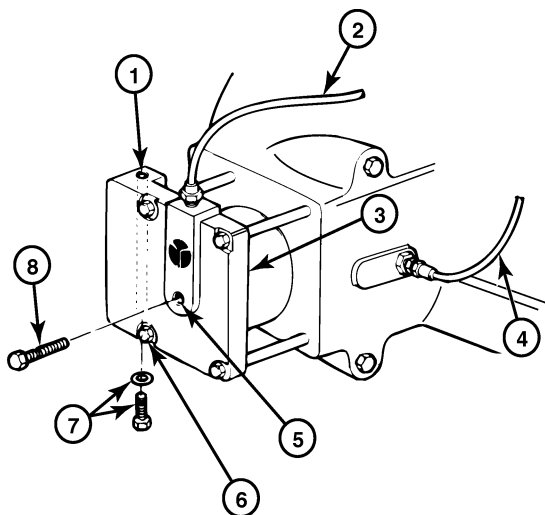

1002839a

- 1 TOP SIDE STORAGE HOLE (FOR MANUAL ENGAGING CAPSCREW)
- 2 AIR LINE
- 3 CYLINDER COVER
- 4 WIRE
- 5 SERVICE POSITION CAPSCREW HOLE
- 6 BOTTOM SIDE STORAGE HOLE FOR PLUG AND GASKET
- 7 PLUG AND GASKET
- 8 MANUAL ENGAGING CAPSCREW

BOLT-ON DCDL ASSEMBLY

Section 6

Driver-Controlled Main Differential Lock

Screw-in Style Differential Lock Cylinder

Use the following manual engaging method to lockout the Screw-In DCDL assembly.

1. Follow steps 1-5 of the "Axle Setup for DCDL Disassembly."
2. Remove the manual engaging capscrew from the storage hole in the carrier casting, adjacent to the cylinder. **Figure 6.3.**
3. Remove air line and fitting and install the manual engaging capscrew into the threaded hole in the center of the cylinder cover.
4. Turn the manual adjusting capscrew to the right until the head is approximately 1/4 inch from the cylinder cover. **Do not** turn the capscrew beyond its normal stop. The capscrew is now in the service position and the main differential lock is completely engaged.
5. Remove the carrier from the axle housing as described in steps 1-7 of "Carrier Removal from Axle."

Figure 6.3

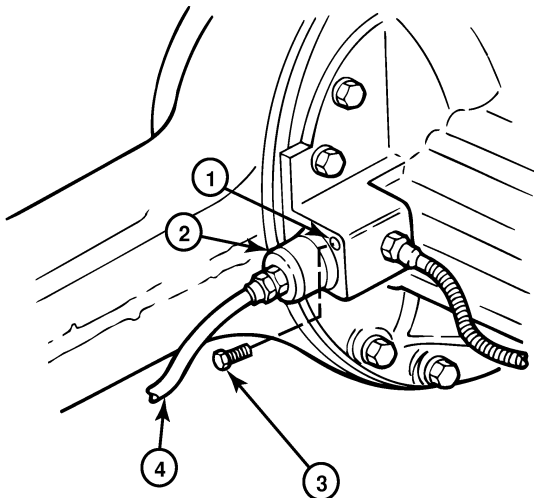

1002838a

- 1 STORAGE HOLE
- 2 CYLINDER
- 3 MANUAL ENGAGING CAPSCREW
- 4 AIR HOSE

THREADED SHIFT ASSEMBLY

Removal of the Differential and Gear Assembly

Removing the Differential Lock Sliding Collar

1. Carriers **with** roll pins: tap out the two retainer roll pins* until they are level with the inner face of the shift fork. Release the differential lock if it is manually engaged. **Figure 6.4.**
2. For carriers **without** roll pins: snap out collar from fork.
3. If required, remove the DCDL assembly at this time.

Figure 6.4

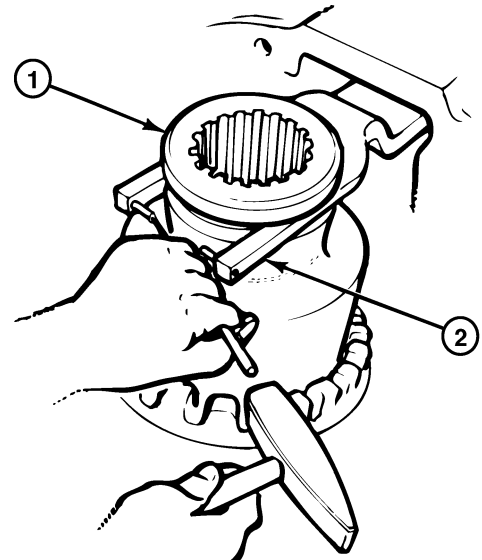

1001110a

- 1 SHIFT COLLAR
- 2 SHIFT FORK

Section 6

Driver-Controlled Main Differential Lock

Bolt-On Style Differential Lock Cylinder

- Remove the sensor switch and lock nut.
- Remove the four capscrews and washers that hold the cylinder cover to carrier. Remove the cylinder cover and copper gasket. **Figure 6.5.**

Figure 6.5

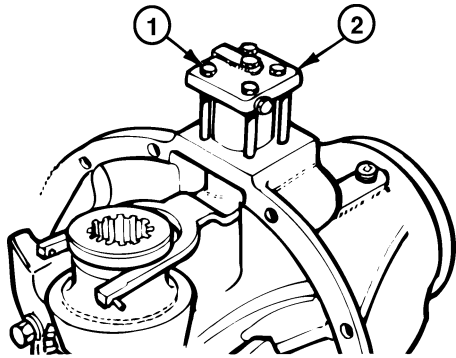

1001111a

- CAPSCREW AND WASHER**
- COVER (COPPER GASKET UNDER COVER)**

BOLT-ON SHIFT ASSEMBLY

- Remove the shift unit-cylinder and piston. Remove the O-ring from the piston.
- Remove the shift shaft from the shift fork. The shaft may be secured with liquid adhesive or pre-applied adhesive material. To break down these secured fasteners, follow the recommended procedure from "Removing Dri-Loc® Fasteners."
- Remove the shift shaft spring and flat washer. Some models use silastic seal instead of the flat washer.
- Remove the shift fork.

NOTE

On some bolt-on assemblies, a roll pin is installed in the shift shaft and is used as a stop for the shift shaft spring. It is not necessary to remove this roll pin during a normal disassembly.

Screw-In Style Differential Lock Cylinder

- Remove sensor switch.
 - Remove cylinder by turning hex nut at top of cylinder with a wrench. The cylinder may be secured to the carrier casting with Loctite® or equivalent pre-applied liquid adhesive. To break down these secured fasteners follow the heating procedure presented in "Removing Dri-Loc® Fasteners."
 - Remove shift shaft, spring, and shift fork.
- Remove the cotter keys*, pins* or lock plates* that hold the two bearing adjusting rings in position. Use a small drift and hammer to remove pins. Each lock plate is held in position by two capscrews.
 - Match mark one bearing cap and one carrier leg so that these parts will be assembled in the correct positions. Remove the bearing cap capscrews and washers, the bearing caps and the adjusting rings.
 - Lift the differential and gear assembly from the carrier. Tilt the assembly as required to permit the ring gear to clear the support for the pinion spigot bearing. **Figure 6.6.**

FURTHER DISASSEMBLY OF THESE CARRIERS IS THE SAME AS AXLES WITHOUT THE DRIVER-CONTROLLED MAIN DIFFERENTIAL LOCK. TO CONTINUE DISASSEMBLY, FOLLOW THE PROCEDURES STARTING WITH "REMOVE THE DIFFERENTIAL AND RING GEAR FROM THE CARRIER."

PREPARE PARTS FOR ASSEMBLY, ADJUSTMENTS, AND CARRIER ASSEMBLY (UP TO THE POINT OF "INSTALL DIFFERENTIAL CARRIER INTO AXLE HOUSING") ARE ALSO THE SAME FOR BOTH AXLES.

Figure 6.6

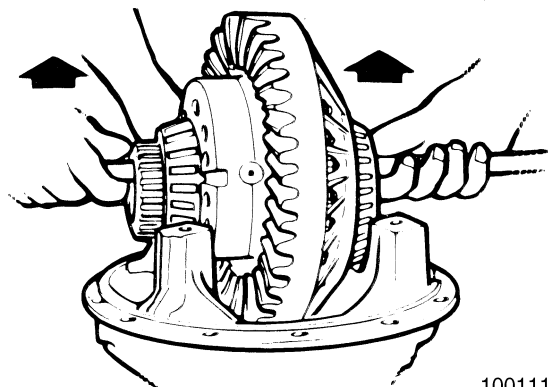

1001112a

Section 6

Driver-Controlled Main Differential Lock

Installation of the DCDL Assembly into Carrier

Bolt-On Style Differential Lock Assembly

Install the differential shift assembly after the differential carrier is assembled and the gear and bearing adjustments are made. Parts of the bolt-on style shift assembly are shown in **Figure 6.7**.

Figure 6.7

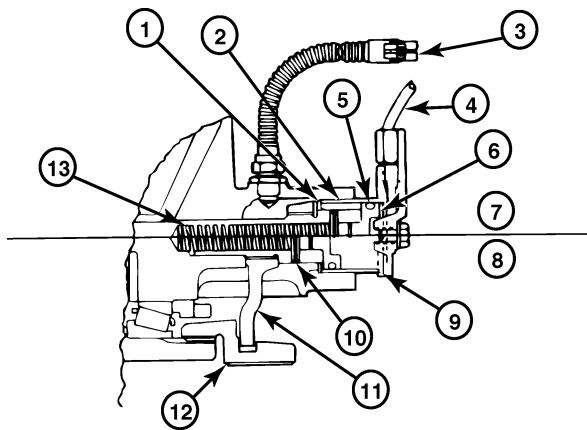

1002860a

- 1 FLAT WASHER OR SILASTIC AS REQUIRED
- 2 CYLINDER
- 3 ELECTRIC CONNECTION FOR SENSOR
- 4 AIR LINE
- 5 O-RING
- 6 PISTON
- 7 (DISENGAGED)
- 8 (ENGAGED)
- 9 COPPER GASKET
- 10 PIN
- 11 SHIFT FORK
- 12 COLLAR
- 13 SHIFT SHAFT AND SPRING

BOLT-ON STYLE

1. On carrier models with shift fork roll pins, install the two roll pins into the ends of the shift fork. Tap the pins into position until they are level with the inner yoke face. **Figure 6.8**. Do not install completely at this time.

Figure 6.8

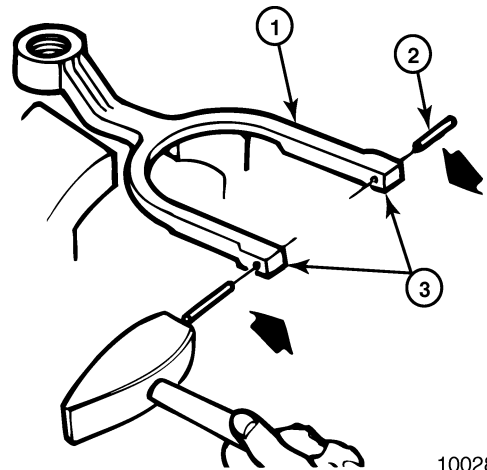

1002861a

- 1 SHIFT FORK
- 2 ROLL PIN
- 3 INNER YOKE FACES

2. On models without roll pins, snap fork into position.
3. Apply Loctite 222 (purple) (RICO Part No. 2297-B-6112) to the threads of the shift shaft.
4. Install the shift fork into its correct position in the carrier case. **Figure 6.9**.

Figure 6.9

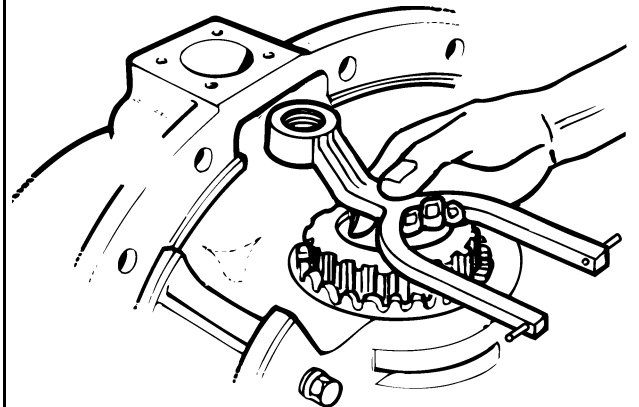

1002862a

Section 6

Driver-Controlled Main Differential Lock

5. Hold the shift fork in position and install the shift shaft spring into the shift shaft opening in the carrier, through the shift fork bore and into the bore for the shift shaft spring. **Figure 6.10.**

Figure 6.10

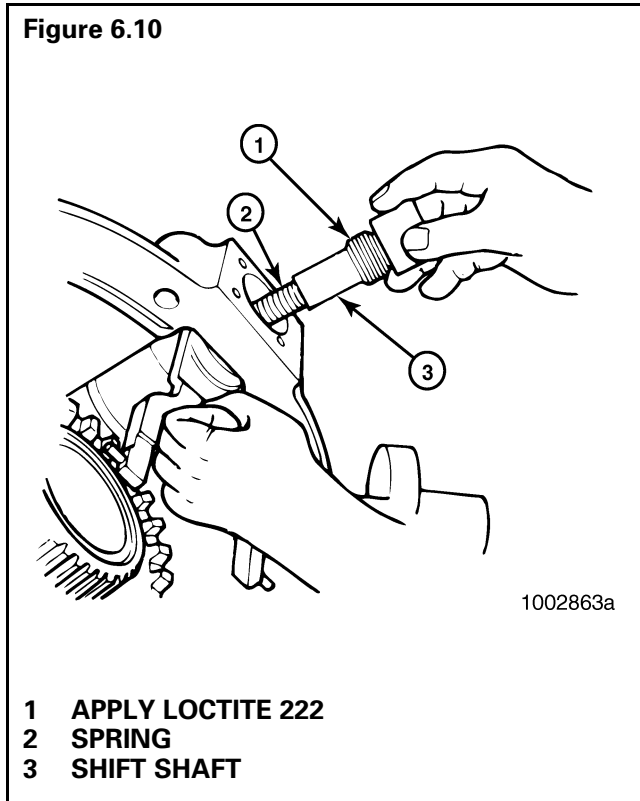
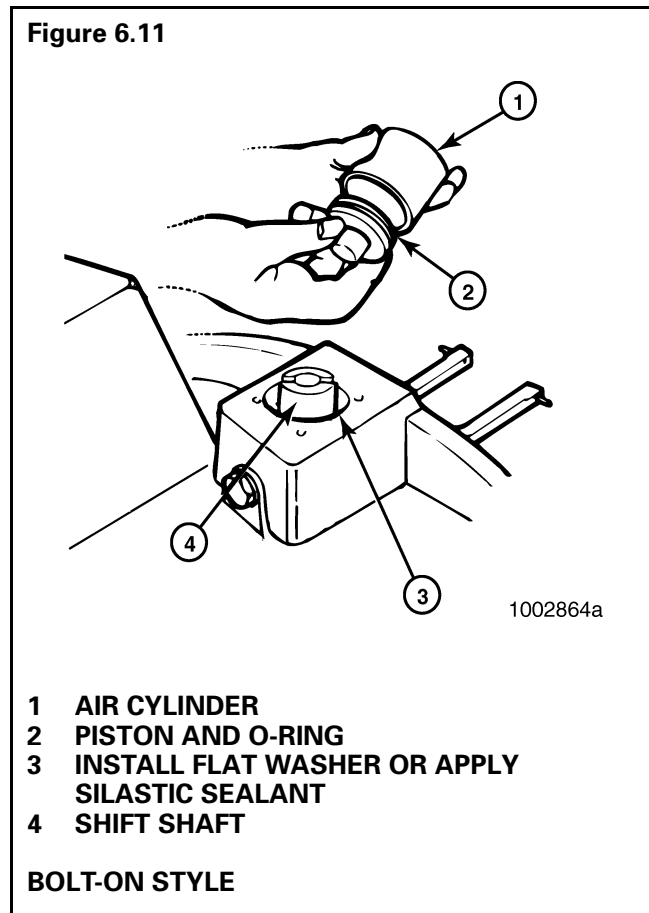

Figure 6.11



6. Slide the shift shaft over the spring and install the shaft into the shift fork. Tighten from 20 to 25 lb-ft (27-34 N•m) torque. **T**
7. Install the flat washer (when used) or apply silastic sealant (RICO Part No. 1199-Q-2981) to the bottom of the cylinder bore. **Figure 6.11.**
8. Install the O-ring into its groove on the piston. Lubricate the O-ring with axle lubricant. Install the piston into the air cylinder. **Figure 6.11.**

Section 6

Driver-Controlled Main Differential Lock

9. Install the cylinder into the housing bore. Make sure that the pilot journal on the piston is against its bore on the shift shaft. **Figure 6.12.**

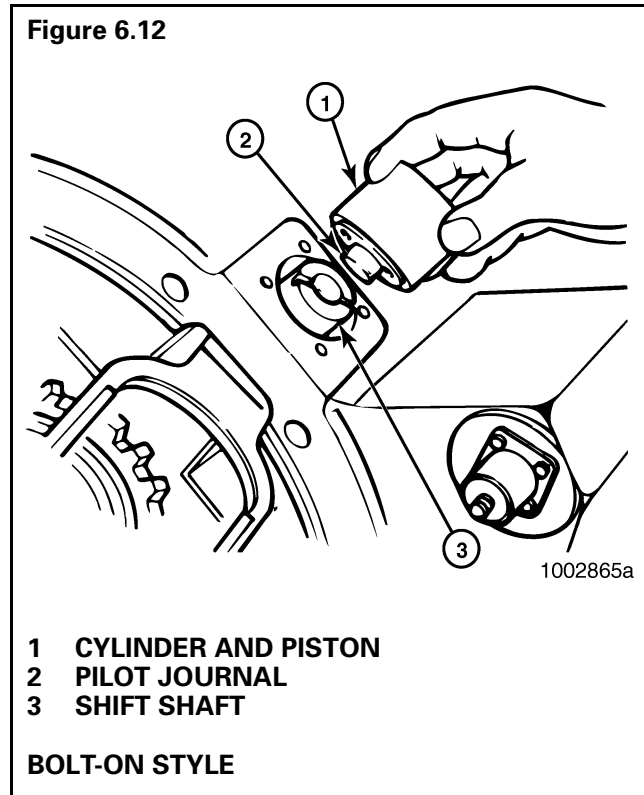

10. Install the copper gasket into its bore on the inside of the cylinder cover. Place the cover in position over the cylinder so that the air intake port will point up when the carrier is installed into the housing. Install the cover with the four attaching capscrews and washers. Tighten from 7.4 to 8.9 lb-ft (10-12 N•m) torque. **Figure 6.7 and Figure 6.13.**

11. Slide the shift collar into the fork and engage the shift collar splines with the splines of the differential case. Use the manual actuation capscrew to move the shift collar splines into the differential case splines. Refer to "Manual Engaging Method."

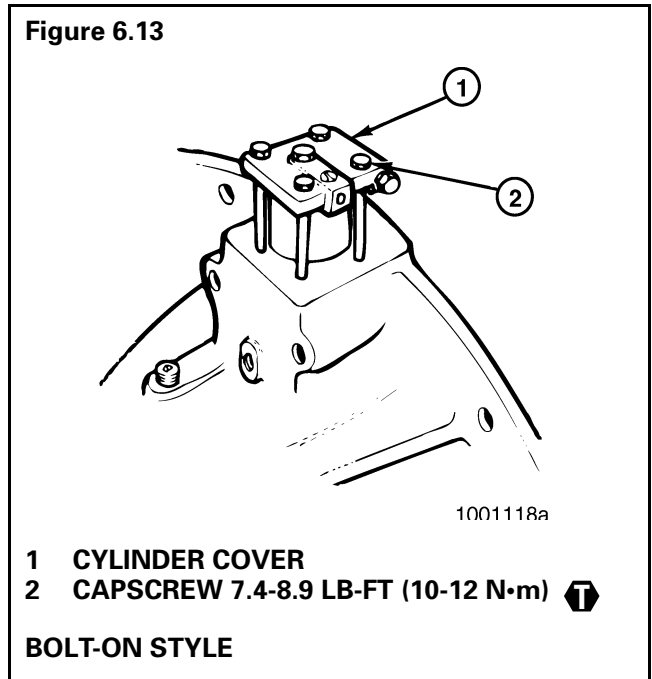

12. Hold the shift collar in the locked (engaged) position. If employed, tap in the two roll pins in the shift fork ends until they are level with the outer yoke faces. **Figure 6.14.**

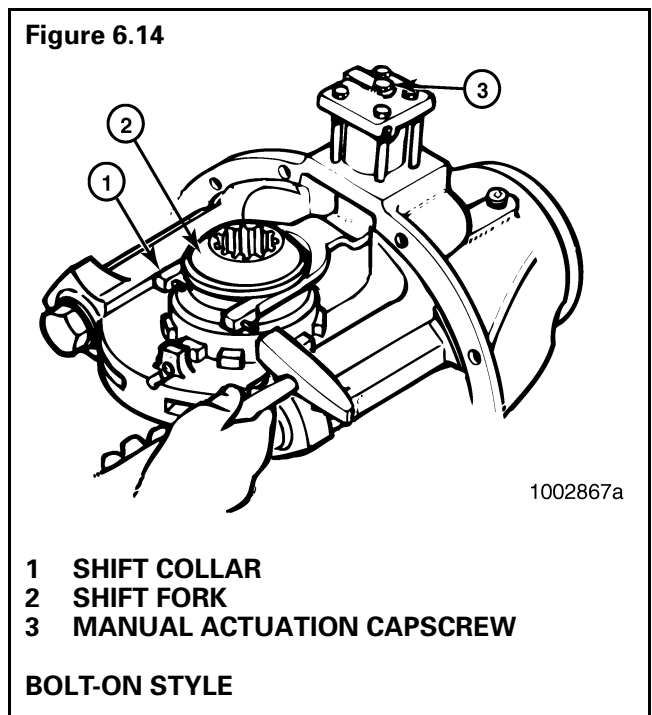

Section 6

Driver-Controlled Main Differential Lock

13. While the shift collar is still in the locked position, place the sensor switch (with the jam nut loosely attached) into its hole.
14. Connect a battery/bulb tester to the sensor switch and rotate the switch into its hole until contact with the shift fork causes the testing light to go on. Turn the switch one additional revolution and tighten the jam nut from 26 to 33 lb-ft (34-45 N•m) torque. 

Screw-In Style Differential Lock Assembly

Install the differential shift assembly after the differential carrier is assembled and the gear and bearing adjustments are made. Parts of the screw-in style shift assembly are shown in **Figure 6.15**.

Figure 6.15

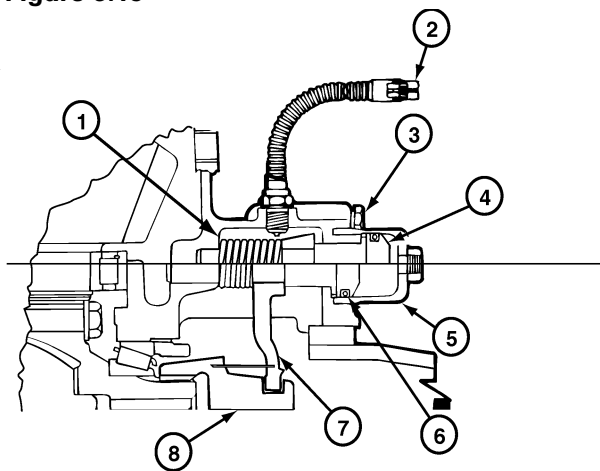

1002851a

- 1 SHIFT SHAFT AND SPRING
- 2 ELECTRIC CONNECTION FOR SENSOR
- 3 PISTON
- 4 (DISENGAGED)
- 5 (ENGAGED)
- 6 CYLINDER
- 7 O-RING
- 8 SHIFT FORK
- 9 COLLAR

SCREW-IN STYLE

1. Install shift spring and fork into the correct position in the carrier case. To facilitate assembly, compress the spring slightly while installing the fork.
2. Install the shift shaft into the shaft bore of the carrier. Slide the shaft through the shift fork bore and shift spring I.D.
3. Inspect piston O-ring. Replace O-ring if there is any evidence of cuts, cracks, abrasion or wear.
4. Lightly lubricate O-ring and DCDL cylinder bore with the same lubricant used in the axle housing.
5. Install piston/O-ring assembly into the DCDL cylinder. Slide piston to the port end of the cylinder.
6. Coat DCDL cylinder threads with Loctite® 518 Gasket Eliminator.
7. Screw DCDL cylinder in place and tighten from 80 to 100 lb-ft (109-136 N•m) torque. **Figure 6.16.** 

Figure 6.16



1001121a

- 1 MANUAL ACTUATION CAPSCREW
- 2 SCREW-IN CYLINDER 80 TO 100 LB-FT (109-136 N•m) 

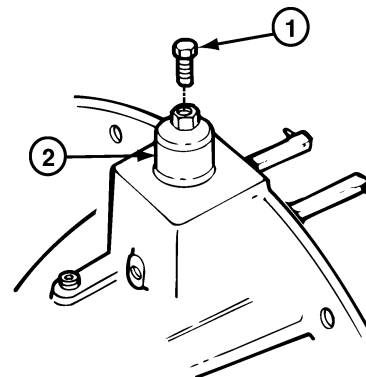
SCREW-IN STYLE

8. Snap the shift collar into the fork and engage the shift collar splines with the splines of the differential case. Use the manual actuation cap screw to move the shift collar splines into the differential case splines. Refer to "Manual Engaging Method."

Section 6

Driver-Controlled Main Differential Lock

9. Install sensor switch into its hole. Tighten from 25 to 35 lb-ft (35-45 N•m). 
10. Connect a battery/bulb tester to the sensor switch. With the DCDL engaged per instructions in step 8, the tester light should go on.
If the light does not go on, perform the following steps:
 - a. Verify fork position — Is it aligned with sensor switch when in engaged position?
 - b. Loose connection — Is the electrical wiring connector tightly seated?
 - c. Sensor switch position — Is it fully seated against spotface of carrier?



If light fails to go on after these checks, the sensor switch should be replaced.

Differential Lock Assembly Cover Plates

NOTE

For carriers without the differential lock (less air shift), assemble the sensor switch plug and cover plate as follows:

Bolt-On Cover Plate Assemblies

1. Install the washer and plug into the hole for the sensor switch. Tighten the plug from 45 to 55 lb-ft (60-74 N•m). **Figure 6.18.** 
2. Apply silicone gasket material to the cover plate mounting surface on the carrier. Refer to "Application of Three Bond 1216 or Equivalent Silicone Gasket Material."
3. Install the four washers and capscrews. Tighten the capscrews from 7.4 to 8.9 lb-ft (10-12 N•m). **Figure 6.17.** 

Screw-In Cover Plate Assemblies

1. Apply Loctite® 518 liquid adhesive to the plate threads.
2. Install the bolts and washers and tighten plate into carrier opening from 7.5 to 9.0 lb-ft (10-12 N•m). 

Figure 6.17



- 1 SENSOR SWITCH PLUG
- 2 WASHER
- 3 SCREW-IN COVER PLATE (APPLY LOCTITE 518 TO COVER PLATE THREADS)
- 4 WASHER
- 5 BOLT-ON COVER PLATE (APPLY SILICONE GASKET MATERIAL)
- 6 CAPSCREW

NOTE

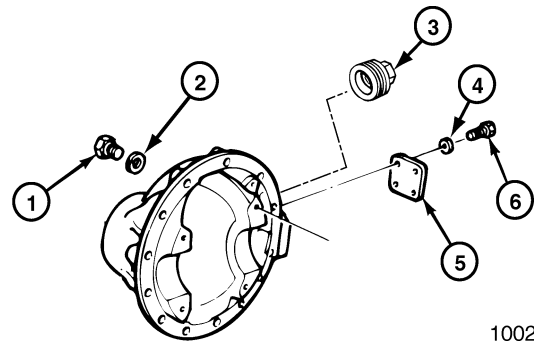
When the carrier is to be installed into the axle housing, the shift collar must be held in the engaged position. This can be done using the manual engaging bolt (refer to "Manual Engaging Method"). Failure to keep the differential in the locked (engaged) position will make it impossible to install the carrier assembly into the axle housing.

After the carrier is installed into the axle housing, shift the differential into the unlocked (disengaged) position to permit the installation of the right-hand axle shaft.

Section 6

Driver-Controlled Main Differential Lock

Installing the Carrier into Axle Housing

 **WARNING**

Solvent cleaners can be flammable, poisonous and cause burns. Examples of solvent cleaners are carbon tetrachloride, emulsion-type cleaners and petroleum-based cleaners. To avoid serious personal injury when you use solvent cleaners, you must carefully follow the manufacturer's product instructions and these procedures:

- *Wear safe eye protection.*
 - *Wear clothing that protects you skin.*
 - *Work in a well-ventilated area.*
 - *Do not use gasoline, or solvents that contain gasoline. Gasoline can explode.*
 - *You must use hot solution tanks or alkaline solutions correctly. Follow the manufacturer's instructions carefully.*
1. Clean the inside of the axle housing and the mounting surface where the carrier fastens. Use a cleaning solvent and rags to remove the dirt. Blow dry the cleaned areas with compressed air. (Refer to "Cleaning Axle Assemblies.")
 2. Inspect the axle housing for damage. If necessary, repair or replace the housing. (Refer to "Repair or Replacement of Parts, General" through "Bending or Straightening Drive Axle Housings.")
 3. Check for loose studs in the mounting surface of the housing where the carrier fastens. Remove and replace any studs where required.
 4. Install the differential carrier into the housing, using the following Manual Engaging Method.

Manual Engaging Method

1. Align the splines of the shift collar and the differential case half. This can be done by hand or by installing the right-hand axle shaft through the shift collar and into the side gear.
2. Install the manual engaging capscrew into the threaded hole in the center of the cylinder cover.
3. Turn the manual adjusting capscrew to the right until the distance from the head of the capscrew is approximately 1/4 to 1/2 inch from the cylinder cover. **Do not** turn the capscrew beyond its normal stop. When the capscrew head is in the service position 1/4 to 1/2 inch from top of DCDL, the main differential lock is manually engaged.

 **CAUTION**

There will be a small amount of spring resistance felt when you turn in the manual engaging capscrew. If a high resistance is felt before reaching the locked (engaged) position, STOP TURNING THE CAPSCREW.

A high resistance on the capscrew indicates that the splines of the shift collar and the differential case half are not aligned or engaged.

Lift the shift collar as required and rotate to align the splines of collar and case half while turning the manual engaging capscrew inward. When the normal amount of spring resistance is again felt on the capscrew, the splines are engaged. Continue to turn in the manual engaging capscrew until the 1/4 to 1/2 inch service position is achieved.

4. Clean both the DCDL actuator and the housing mounting surfaces.
5. Apply silicone gasket material to the cleaned housing surface for the DCDL actuator. Refer to "Application of Three Bond 1216 or Equivalent Silicone Gasket Material."
6. Remove the short plug and gasket from the storage hole of the DCDL.
7. Remove the long manual engaging capscrew from the center of the DCDL.

Section 6

Driver-Controlled Main Differential Lock

NOTE

When the manual engaging capscrew is removed from the service position in the center of the DCDL actuator, the main differential lock is disengaged.

8. Clean the plug, gasket, cylinder cover, and threaded service position hole in the center of the DCDL cylinder cover.
9. Install the manual engaging capscrew into the DCDL storage hole in the bolt-on or the screw-in DCDL assembly. **Figure 6.18** and **Figure 6.19**.

NOTE

Check to ensure sealing gasket is under the head of the capscrew.

- a. On a bolt-on DCDL shift assembly, remove the short plug and gasket from the storage hole of the DCDL.

Install the short plug and gasket into the service position hole in the center of the DCDL. Refer to **Figure 6.18**.

- b. On a screw-in DCDL shift assembly, install the short screw (plug) into the storage hole located in the top of the screw-in DCDL shift assembly. **Figure 6.19**.

Figure 6.18

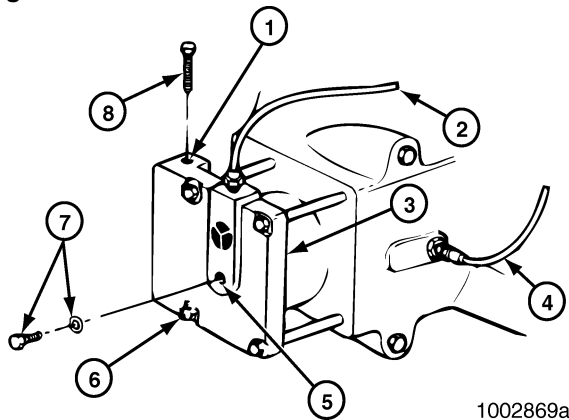

1002869a

- 1 TOP STORAGE HOLE FOR MANUAL ENGAGING CAPSCREW
- 2 AIR LINE
- 3 CYLINDER COVER
- 4 WIRE
- 5 SERVICE POSITION CAPSCREW HOLE
- 6 BOTTOM STORAGE HOLE FOR PLUG AND GASKET
- 7 PLUG AND GASKET
- 8 MANUAL ENGAGING CAPSCREW

BOLT-ON DCDL SHIFT ASSEMBLY

Figure 6.19

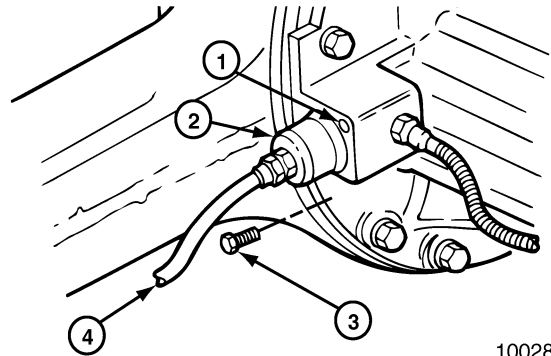

1002870a

- 1 STORAGE HOLE
- 2 CYLINDER
- 3 MANUAL ENGAGING CAPSCREW
- 4 AIR HOSE

SCREW-IN DCDL SHIFT ASSEMBLY

10. Tighten the plug* from 44 to 55 lb-ft (60-75 N•m) torque. Tighten the manual engaging capscrew from 22 to 28 lb-ft (30-38 N•m) for bolt-on style cylinders and from 7 to 11 lb-ft (10-15 N•m) for screw-in type reverse shifters. **T**
11. Connect the vehicle air line to the differential lock actuator assembly.
12. Install the electrical connection on the sensor switch located in the carrier, below the actuator assembly.
13. Install the right and left-hand axle shafts. Follow the procedures from "Before Towing or Drive-Away" in Section 10, "Vehicle Towing Instructions."
14. Remove the jack stand from under the drive axle and lower the vehicle to the floor.
15. Proceed to "Check the Differential Lock."

Section 6

Driver-Controlled Main Differential Lock

Check the Differential Lock

1. Shift the vehicle transmission to neutral and start the engine to get the system air pressure to the normal level.



WARNING

During DCDL disassembly, when the DCDL is in the locked (engaged) position and one of the vehicle's wheels is raised from the floor, do not start the engine and engage the transmission. The vehicle can move and cause serious personal injury.

2. Place the differential lock switch (in the cab of the vehicle) in the unlocked (disengaged) position.
3. Drive the vehicle at 5 to 10 mph (8-16 km/h) and check the differential lock indicator light. The light must be off when the switch is in the unlocked (disengaged) position.
4. Continue to drive the vehicle and place the differential lock switch in the locked (engaged) position. Let up on the accelerator to remove the driveline torque and permit the shift. The light must be on when the switch is in the locked position.

NOTE

If the indicator light remains "on" with the switch in the unlocked position, the differential is still in the locked position. Check to make sure that the manual engaging capscrew was removed from the cylinder cover of the actuator assembly. Refer to steps 6 through 12 of "Manual Engaging Method."

Driver Caution Label

Figure 6.20

Check to see that the "Driver Caution" label is installed in the vehicle cab. The caution label must be placed in a location that is easily visible to the driver. A recommended location is on the instrument panel, next to the differential lock switch and lock indicator light. **Figure 6.20.**

Driver Caution labels (TP-86101) are available from RICO, Troy, Michigan.

Figure 6.20

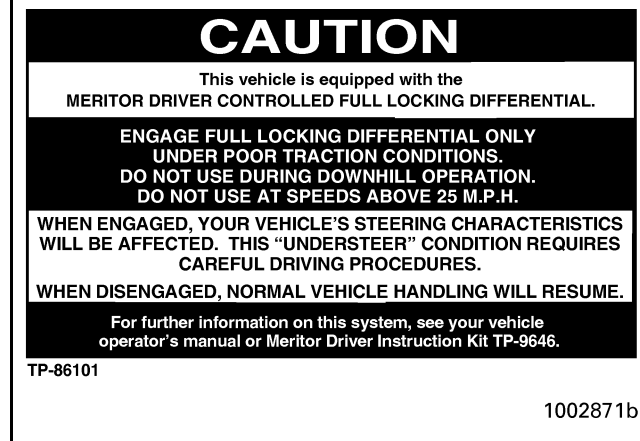

Traction Control Video Package

The package, entitled *Traction Controls*, contains two videos — the all-new *Splitting the Difference* and *Driver-Controlled Full Locking Main Differential*.

Driver-Controlled Full Locking Main Differential is one of the industry's best videos on the operation of the main differential. The video explains in full detail how this system works and further discusses the advantages of Meritor's unique traction control device — DCDL. Testimonials from a large North American fleet support the ease of use of the DCDL.

Also included in the package are several technical pieces to supplement the videos by providing detailed instructions on operating the DCDL and IAD, driver instructions and the difference between the two systems.

A copy of the video package may be obtained for \$50.00 by requesting item number T-95125V from RICO Automotive, Literature Distribution, 35000 Industrial Road, Livonia, Mich. 48150, or call RICO at 800-535-5560. Each video is available individually as well, *Splitting the Difference* (T-87127V) and *Driver-Controlled Full Locking Main Differential* (T-9007V).

Section 7 Lubrication

NOTE

For complete information on lubricating drive axles and carriers, refer to *Maintenance Manual 1, Lubrication*.

Refer to **Table G**, **Table H** and **Table I** for standard information on lubricants, schedules and capacities.

Table G – Lubricant Cross Reference (Viscosity) and Temperature Chart

RICO Lubricant Specification	Description	Cross Reference	Minimum Outside Temperature	Maximum Outside Temperature
0-76-A	Hypoid Gear Oil	GL-5, S.A.E. 85W/140	+10°F (-12.2°C)	---**
0-76-B	Hypoid Gear Oil	GL-5, S.A.E. 80W/140	-15°F (-26.1°C)	---**
0-76-D	Hypoid Gear Oil	GL-5, S.A.E. 80W/90	-15°F (-26.1°C)	---**
0-76-E	Hypoid Gear Oil	GL-5, S.A.E. 75W/90	-40°F (-40°C)	---**
0-76-J	Hypoid Gear Oil	GL-5, S.A.E. 75W	-40°F (-40°C)	+35°F (+ 1.6°C)
0-76-L	Hypoid Gear Oil	GL-5, S.A.E. 75W/140	-40°F (-40°C)	---**

There is no upper limit on these outside temperatures, but the axle sump temperature **must never exceed +121°C (250°F).

Table H – Oil Change Intervals and Specifications for All Front Drive and Rear Drive Axles ①

Vocation or Vehicle Operation	Linehaul Motorhome Intercity Coach	City Delivery School Bus Fire Truck	Construction Transit Bus Refuse Yard Tractor Logging Heavy Haul Mining Oil Field Rescue
Initial Oil Change	No longer required as of January 1, 1993		
Check Oil Level	Every 25,000 miles (40,000 km) or the fleet maintenance interval (whichever comes first)	Every 10,000 miles (16,000 km), once a month or the fleet maintenance interval (whichever comes first)	Every 5,000 miles (8,000 km), once a month or the fleet maintenance interval (whichever comes first) ②
Petroleum based oil change on axle WITH or WITHOUT pump and filter system	Every 100,000 miles (160,000 km) or annually, whichever comes first	Every 50,000 miles (80,000 km) or annually, whichever comes first	Every 25,000 miles (40,000 km) or annually, whichever comes first
Synthetic oil change on axle WITHOUT pump and filter system ③	Every 250,000 miles (400,000 km) or annually, whichever comes first	Every 100,000 miles (160,000 km) or annually, whichever comes first	Every 50,000 miles (80,000 km) or annually, whichever comes first
Synthetic oil change on axle WITH pump and filter system ③	Every 500,000 miles (800,000 km)	Every 250,000 miles (400,000 km)	Every 100,000 miles (160,000 km)
Filter change on axle with pump and filter system	Every 100,000 miles (160,000 km)	Every 100,000 miles (160,000 km)	Every 100,000 miles (160,000 km)

① If a No-Spin differential is installed, change the oil (petroleum or synthetic) at a minimum interval of 40,000 miles (64,000 km) or a maximum interval of 50,000 miles (80,000 km).

② For continuous heavy-duty operation, check the oil level every 1,000 miles (1,600 km). Add the correct type and amount of oil as required.

③ This interval applies to approved semi-synthetic and full synthetic oils only. For a list of approved extended-drain axle oils, refer to TP-9539, *Approved Rear Drive Axle Lubricants*. To order this publication, call Meritor's Customer Service Center at 800-535-5560.

Section 7 Lubrication

Lubricant Capacities

Use the following lubricant capacities as a guide only. The capacities are measured with the drive pinion in the horizontal position. When the angle of the drive pinion changes, the lubricant capacity of the axle will change.

Table I

Axle Model	Capacity	
	U.S. Pints	Liters
Single Drive Axles		
RF-7-120	15.3	7.2
RF-9-120	15.3	7.2
RF-12-120	15.3	7.2
RF-12-125	15.3	7.2
RF-16-145	36.4	17.2
RF-21-155	27.9	13.2
RF-21-156	27.9	13.2
RF-21-160	43.7	20.7
RF-21-185	39.3	18.6
RF-21-355	28.0	13.2
RF-22-166	43.7	20.7
RF-23-180	39.3	18.6
RF-23-185	39.3	18.6
RS-13-120	15	7.2
RS-15-120	15	7.2
RS-16-140	33.6	15.9
RS-16-141	33.6	15.9
RS-16-145	33.6	15.9
RS-17-140	32	15.4
RS-17-141	33.6	15.9
RS-17-144	32.3	15.3
RS-17-145	33.6	15.9
RS-19-144	32.3	15.3
RS-19-145	36	17.3
RS-21-145	35	16.9
RS-21-160	39.5	18.7
RS-23-160	43/41	20.7/19.5
RS-23-160A	39.5	18.7
RS-23-161/161A	37.2	17.6
RS-23-180	39	18.6
RS-23-185	39	18.6
RS-23-186	39	18.6
RS-25-160	39	18.6
RS-25-160A	37.2	17.6
RS-26-160	51	24.2
RS-26-180	38	18.3
RS-26-185	38	18.3
RS-30-180	38	18.3
RS-30-185	38	18.3
* Includes 1 pint (0.97 liter) for each wheel end and with drive pinion angle at 3°.		

Axle Model	Capacity	
	U.S. Pints	Liters
Rear Axle of Tandems		
RT-34-140 (RR-17-140)	35	16.9
RT-34-144	25.8	12.2
RT-34-145 (RR-17-145 rear)	36	17.1
RT-34-145P	25.4	12.0
RT-34-146	25.4	12.0
RT-40-140 (RR-20-140)	35	16.9
RT-40-145/149 (RR-20-145 rear)	36	17.3
RT-40-145P	25.8	12.2
RT-40-146	25.8	12.2
RT-40-160	34.4	16.3
RT-40-169	34.4	16.3
RT-44-145 (RR-22-145 rear)	35	16.9
RT-44-145P	25.1	11.9
RT-46-160/169 (RR-23-160 rear)	43/41	20.7/19.5
RT-46-160A/160P	34.4	16.3
RT-46-164	33.2	15.7
RT-46-164EH/16HEH	33.2	15.7
RT-48-180 (RR-24-180 rear)	39	18.6
RT-50-160/160P	33.2	15.7
RT-52-160 (RR-26-160 rear)	51	24.2
RT-52-180/185 (RR-26-180 rear)	39	18.3
RT-58-180/185 (RR-29-180 rear)	39	18.3

Section 8

Fastener Torque Information

Torque Values for Fasteners

General Information

1. The torque values in **Table J** are for fasteners that have a light application of oil on the threads.
2. If the fasteners are dry, increase the torque values by ten percent (10%).
3. If the fasteners have a heavy application of oil on the threads, decrease the torque values by ten percent (10%).
4. If you do not know the size of the fastener that is being installed, measure the fastener. Use the following procedure.

American Standard Fasteners

- a. Measure the diameter of the threads in inches, dimension X. **Figure 8.1.**
- b. Count the amount of threads there are in one inch (1.0 inch). **Figure 8.1.**

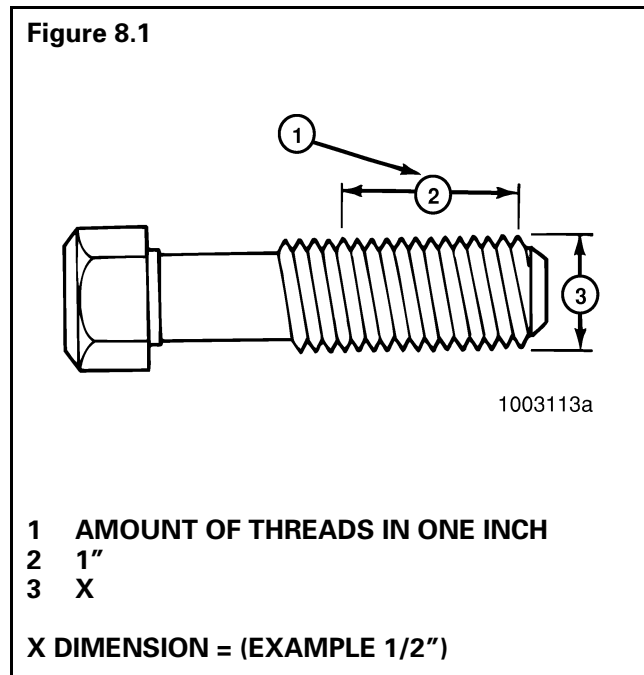

Example

- American Standard size fastener is .50-13.
 - 0.50 is the diameter of the fastener in inches or dimension X.
 - 13 is the amount of threads in one inch (1.0 inch).

Metric Fasteners

- a. Measure the diameter of the threads in millimeters (mm), dimension X. **Figure 8.2.**

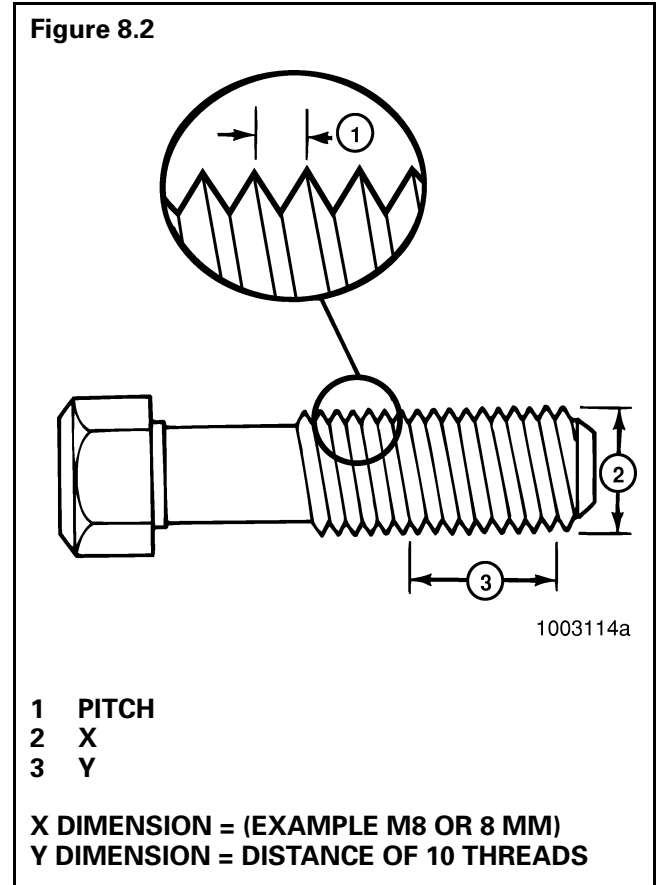

- b. Measure the distance of ten (10) threads, point to point in millimeters (mm), dimension Y. Make a note of dimension Y. **Figure 8.2.**
- c. Divide dimension Y by ten (10). The result will be the distance between two threads or pitch.

Example

- Metric size fastener is M8 x 1.25.
 - M8 is the diameter of the fastener in millimeters (mm) or dimension X.
 - 1.25 is the distance between two threads or pitch.
5. Compare the size of fastener measured in step 4 to the list of fasteners in **Table J** to find the correct torque value.

Section 8

Fastener Torque Information

Figure 8.3

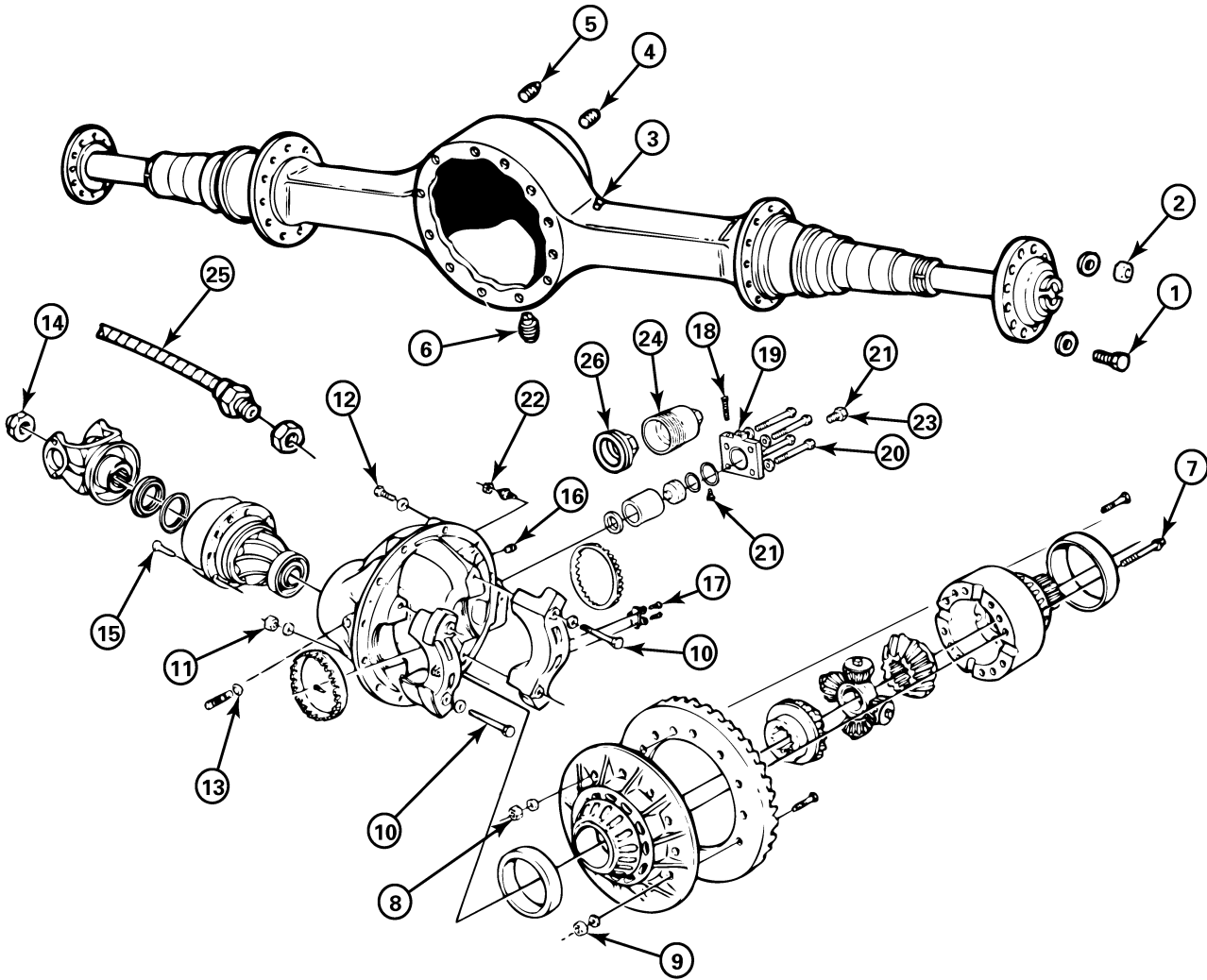

1003351a

Section 8

Fastener Torque Information

Table J — Torque Chart

Fastener		Thread Size	Torque Value lb-ft (N·m)	
1.	*Capscrew, Axle Shaft	.31-24 .50-13	18-24 85-115	(24-33) (115-156)
2.	*Nut, Axle Shaft Stud	Plain Nut .44-20 .50-20 .56-18 .62-18 Lock Nut .44-20 .50-20 .56-18 .62-18	50-75 75-115 110-165 150-230 40-65 65-100 100-145 130-190	(68-102) (102-156) (149-224) (203-312) (54-88) (88-136) (136-197) (176-258)
3.	Breather	.38-18	20 minimum (27 minimum)	
4.	*Plug, Oil Fill (Housing)	.75-14	35 minimum (47.5 minimum)	
5.	*Plug, Heat Indicator	.50-14	25 minimum (34 minimum)	
6.	Plug, Oil Drain	.50-14	25 minimum (34 minimum)	
7.	Capscrew, Differential Case Grade 10.9 Flange Head Grade 10.9 Standard Hex Head Grade 12.9 Standard Hex Head Grade 12.9 Flange Head Grade 12.9 Standard Head	.38-16 .44-14 .50-13 .56-12 .62-11 M12 x 1.75 M12 x 1.75 M12 x 1.75 M16 x 2 M16 x 2	35-50 60-75 85-115 130-165 180-230 85-103 74-96 105-125 203-251 220-310	(48-68) (81-102) (115-156) (176-224) (244-312) (115-140) (100-130) (143-169) (275-340) (300-420)
8.	*Nut, Differential Case Bolt	.50-13 .50-20 .62-11 .62-18 M12 x 1.75 M16 x 2	75-100 85-115 150-190 180-230 74-96 220-310	(102-136) (115-156) (203-258) (244-312) (100-130) (300-420)
9.	*Nut, Ring Gear Bolt Flange Head Standard Hex Head	.50-13 .50-20 .62-11 .62-18 M12 x 1.25 M12 x 1.75 M16 x 1.5 M16 x 1.5	75-100 85-115 150-190 180-230 66-81 77-85 192-214 196-262	(102-136) (115-156) (203-258) (244-312) (90-110) (104-115) (260-190) (265-355)
10.	Capscrew, Bearing Cap	.56-12 .62-11 .75-10 .88-14 .88-9 M16 x 2 M20 x 2.5 M22 x 2.5	110-145 150-190 270-350 360-470 425-550 181-221 347-431 479-597	(149-197) (203-258) (366-475) (488-637) (576-746) (245-300) (470-585) (650-810)
11.	Nut, Housing to Carrier Stud	.44-20 .50-20 .56-18 .62-18	50-75 75-115 110-165 150-230	(68-102) (102-156) (149-224) (203-312)

Section 8

Fastener Torque Information

Table J — Torque Chart (Continued)

Fastener		Thread Size	Torque Value lb-ft (N•m) 	
12.	Capscrew, Carrier to Housing	.44-14 .50-13 .56-12 .62-11 .75-10 M12 x 1.75 M16 x 2	50-75 75-115 110-165 150-230 270-400 74-89 181-221	(68-102) (102-156) (149-224) (203-312) (366-542) (100-120) (245-300)
13.	*Jam Nut, Thrust Screw	.75-16 .88-14 1.12-16 M22 x 1.5 M30 x 1.5	150-190 150-300 150-190 148-210 236-295	(203-258) (203-407) (203-258) (200-285) (320-400)
14.	Input Yoke-to-Input Shaft Nut	Refer to Table K.		
15.	Capscrew, Bearing Cage	.38-16 .44-14 .50-13 .56-12 .62-11 M12 x 1.75	30-50 50-75 75-115 110-165 150-230 70-110	(41-68) (68-102) (102-156) (149-224) (203-312) (90-150)
16.	*Plug, Oil Fill (Carrier)	.75-14 1.5-11.5 M24 x 1.5	25 minimum (34 minimum) 120 minimum (163 minimum) 35 minimum (47 minimum)	
17.	*Capscrew, Lock Plate	.31-18 M8 x 1.25	20-30 21-26	(27-41) (28-35)

Torque Values are for Carriers with Bolt-On Style Differential Lock Cylinders

Fastener		Thread Size	Torque Value lb-ft (N•m) 	
18.	Capscrew, Manual Actuation (Storage Position)	M10 x 1.5	15-25	(20-35)
19.	Adapter, Air Cylinder	M12 x 1.5	22-30	(30-40)
20.	Capscrew, Air Cylinder Cover	M6 x 1	7-12	(10-16)
21.	Capscrew/Plug, Air Cylinder Cover (Operating Position) (Storage Position)	M10 x 1.5	15-25 15-25	(20-35) (20-35)
22.	Lock Nut, Sensor Switch	M16 x 1	25-35	(35-45)

Torque Values are for Carriers with Screw-In Style Differential Lock Cylinders

Fastener		Thread Size	Torque Value lb-ft (N•m) 	
23.	Capscrew, Manual Actuation (Storage Position)	M10 x 1.25	7-11	(10-15)
24.	Air Cylinder	M60 x 2.0	80-100	(109-136)
25.	Sensor Switch	M16 x 1.0	25-35	(35-45)
26.	Screw-In DCDL Cylinder Plug or Cap	M60 x 2.0	80-100	(109-136)

Section 8

Fastener Torque Information



Table K — Input and Output Yoke Pinion Nut Fastener Torque Specifications

Single and Rear of Tandem Axles

Axle Model Pinion Nut Location	RS-120, RS-125, RS-140	RS-144/145	RF-166, RS-160, RS-161, RS-185, RS-186	RS-210, RS-220, RS-230	RS-240	RS-380
Carrier Input Yoke	740-920 lb-ft (1000-1245 N•m) Fastener Size: M32 X 1.5	920-1130 lb-ft (1250-1535 N•m) Fastener Size: M39 X 1.5	1000-1230 lb-ft (1350-1670 N•m) Fastener Size: M45 X 1.5	740-920 lb-ft (1000-1245 N•m) Fastener Size: M32 X 1.5	740-920 lb-ft (1000-1245 N•m) Fastener Size: M39 X 1.5	800-1100 lb-ft (1085-1496 N•m) Fastener Size: 1-1/2 - 12 UNF

Section 9 Adjustments and Specifications

Drive Pinion Bearings — Preload (Refer to Section 5, "Assembly")

Specification	<p>New bearings</p> <ul style="list-style-type: none"> — 15 to 25 lb-in (1.7-2.8 N•m) torque  <p>Used bearings</p> <ul style="list-style-type: none"> — 15 to 25 lb-in (1.7-2.8 N•m) torque 
Adjustment	<p>Preload is controlled by the thickness of the spacer between bearings.</p> <ul style="list-style-type: none"> — To increase preload install a thinner spacer — To decrease preload install a thicker spacer

Drive Pinion — Depth in Carrier (Refer to Section 5, "Assembly")

Specification	<p>Install the correct amount of shims between the bearing cage and carrier. To calculate, use old shim pack thickness and new and old pinion cone numbers.</p>
Adjustment	<p>Change the thickness of the shim pack to get a good gear tooth contact pattern.</p>

Hypoid Gear Set — Tooth Contact Patterns (Hand Rolled) (Refer to Section 5, "Assembly")

Specification	<p>Conventional gear set</p> <ul style="list-style-type: none"> — Toward the toe of the gear tooth and in the center between the top and bottom of the tooth <p>Generoid gear set</p> <ul style="list-style-type: none"> — Between the center and toe of the tooth and in the center between the top and bottom of the tooth
Adjustment	<p>Tooth contact patterns are controlled by the thickness of the shim pack between the pinion bearing cage and carrier and by ring gear backlash</p> <ul style="list-style-type: none"> — To move the contact pattern lower, decrease the thickness of the shim pack under the pinion bearing cage — To move the contact pattern higher, increase the thickness of the shim pack under the pinion bearing cage — To move the contact pattern toward the toe of the tooth, decrease backlash of the ring gear — To move the contact pattern toward the heel of the tooth, increase backlash of the ring gear

Main Differential Bearings — Preload (Refer to Section 5, "Assembly")

Specification	<p>15 to 35 lb-in (1.7-3.9 N•m) torque </p> <p style="text-align: center;"><i>or</i></p> <p>Expansion between bearing caps</p> <ul style="list-style-type: none"> — RS-140, RS-145 and RS-160 carrier models — 0.002 to 0.009 inch (0.05-0.229 mm) — All other carrier models — 0.006 to 0.013 inch (0.15-0.33 mm)
Adjustment	<p>Preload is controlled by tightening both adjusting rings after zero end play is reached</p>

Section 9

Adjustments and Specifications

Main Differential Gears — Rotating Resistance (Refer to Section 5, “Assembly”)

Specification	50 lb-ft (68 N•m) torque applied to one side gear 
----------------------	---

Ring Gear — Backlash (Refer to Section 5, “Assembly”)

Specification	<p>Ring gears that have a pitch diameter of less than 17 inches (431.8 mm)</p> <ul style="list-style-type: none"> — Range: 0.008 to 0.018 inch (0.20-0.46 mm) <li style="padding-left: 40px;">0.012 inch (0.30 mm) for a new gear set <p>Ring gears that have a pitch diameter of 17 inches (431.8 mm) or greater</p> <ul style="list-style-type: none"> — Range: 0.010 to 0.020 inch (0.25-0.51 mm) <li style="padding-left: 40px;">0.015 inch (0.38 mm) for a new gear set
Adjustment	<p>Backlash is controlled by the position of the ring gear. Change backlash within specifications to get a good tooth contact pattern.</p> <ul style="list-style-type: none"> — To increase backlash, move the ring gear away from the drive pinion — To decrease backlash, move the ring gear toward the drive pinion

Ring Gear — Runout (Refer to Section 5, “Assembly”)

Specification	0.008 inch (0.20 mm) maximum
----------------------	------------------------------

DCDL Sensor Switch — Installation (Refer to Section 5, “Assembly”)

Specification	Shift the differential to the locked position. Tighten the sensor switch into the carrier until the test light comes on. Tighten the sensor switch one additional turn and tighten lock nut to correct torque value.
----------------------	--

Spigot Bearing — Peening on the Drive Pinion (Refer to Section 6, “Driver Controlled Main Differential Lock”)

Specification	Apply 6,614 lb (3,000 kg) load on a 0.375 inch or 10 mm ball. Peen the end of the drive pinion at a minimum of five points. Softening of the pinion stem end by heating may be required.
----------------------	--

Section 10

Vehicle Towing Instructions

TYPE OF AXLE:

These instructions are for vehicles equipped with single or tandem rear drive axles.

- **SINGLE AXLE, with Driver Controlled Main Differential Lock (DCDL — Screw-In [threaded] shift assembly)**
- **TANDEM AXLE, with Driver Controlled Main Differential Lock (DCDL — Screw-In [threaded] shift assembly) and with Inter-Axle Differential (IAD)**

The instructions supersede all other instructions for the purpose of transporting vehicles for service or new vehicle drive-away dated before April 1995, including those contained in RICO Maintenance Manuals.

When transporting a vehicle with the wheels of one or both drive axles on the road, it is possible to damage the axles if the wrong procedure is used before transporting begins. RICO recommends that you use the following procedure.



CAUTION

If the vehicle is equipped with a front drive axle, tow the vehicle from the front, with the front wheels off the ground. If this is not possible, you must remove the front drive shaft before towing.

Before Towing or Drive-Away

WARNINGS

⚠ To prevent serious eye injury, always wear safe eye protection when you perform vehicle maintenance or service.

⚠ Engage the parking brake to prevent the vehicle from moving before you begin maintenance or service procedures that require you to be under the vehicle. Serious personal injury can result.

1. Apply the vehicle parking brakes using the switch inside the cab of the vehicle.
2. Shift the transmission into neutral and start the vehicle's engine.
3. Shift the DCDL and the IAD to the unlocked (disengaged) positions using the switches inside the cab of the vehicle. The indicator lights in the cab will go off.
4. Stop the engine.

NOTE

Remove only the axle shaft(s), shown in Table L at this time, from the axle(s) that will remain on the road when the vehicle is transported. Continue with step 5.

5. Remove the stud nuts or capscrews and the washers from the flange of the axle shaft. **Figure 10.1.**

Table L

Single Axles
Remove the left-hand (road side) axle shaft
Tandem Axles
Forward Axle: Remove the right-hand (curb side) axle shaft
Rear Axle: Remove the left-hand (road side) axle shaft



CAUTION

Do not use a chisel or wedge to loosen the axle shaft and tapered dowels. Using a chisel or wedge can result in damage to the axle shaft, the gasket and seal, and/or the axle hub.

6. Loosen the tapered dowels, if used, in the flange of the axle shaft using one of the two following methods. **Figure 10.1.**

Figure 10.1

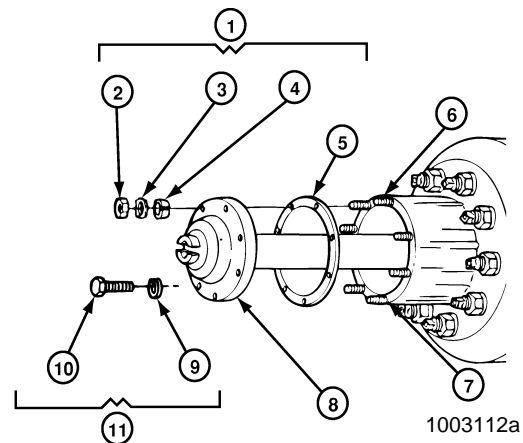

- | | |
|----------------------------------|---------------------------------------|
| 1 TAPERED DOWEL RETENTION | 7 SHAFT HUB AXLE |
| 2 STUD NUT | 8 AXLE SHAFT (FLANGE) |
| 3 WASHER | 9 WASHER |
| 4 TAPERED DOWEL | 10 CAPSCREW |
| 5 GASKET | 11 NON-TAPERED DOWEL RETENTION |
| 6 STUD | |

Section 10

Vehicle Towing Instructions

7. Brass Drift Method:

WARNING

Do not strike the round driving lugs on the flange of an axle shaft. Pieces can break off and cause serious personal injury.

NOTE

A 1.5 inch (38.1 mm) diameter brass hammer can be used as a drift.

- Hold a 1.5 inch (38.1 mm) diameter brass drift against the center of the axle shaft flange, **inside the round driving lugs**. **Figure 10.2**.
- Hit the end of the drift with a large hammer (5 to 6 pounds, 2.3 to 2.7 kg) to loosen the axle shaft and tapered dowels from the hub. **Figure 10.2**.

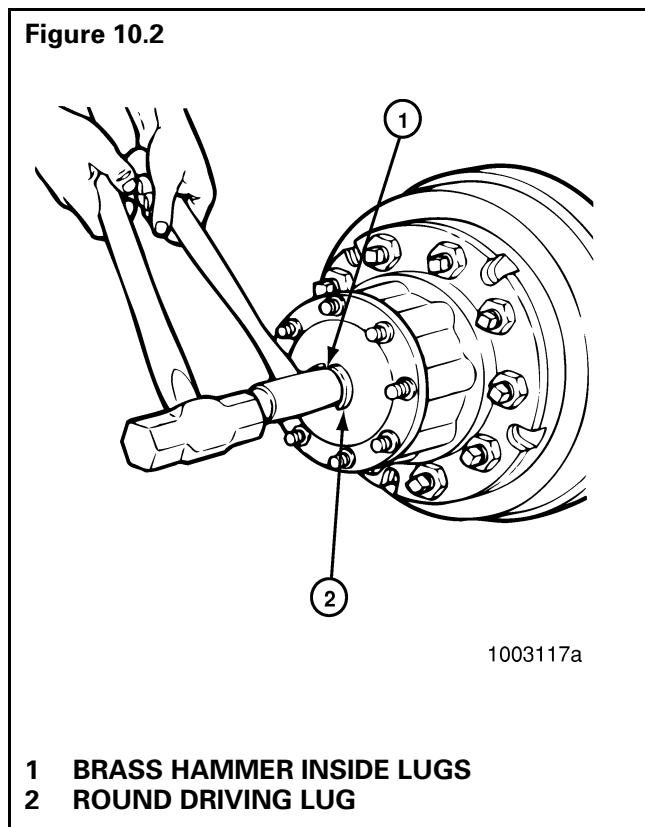

8. Air Hammer Vibration Method:

WARNING

Wear safe eye protection when using an air hammer. Power tools and components can loosen and break and cause serious personal injury.

- Use an air hammer, such as Chicago Pneumatic CP-4181-PULER, or equivalent, with a round hammer bit to loosen the axle shaft and dowels.
- Place the round hammer bit against the axle shaft flange between the studs, at different points around the flange. Operate the air hammer at each location and loosen the axle shaft and tapered dowels from the hub. **Figure 10.3**.

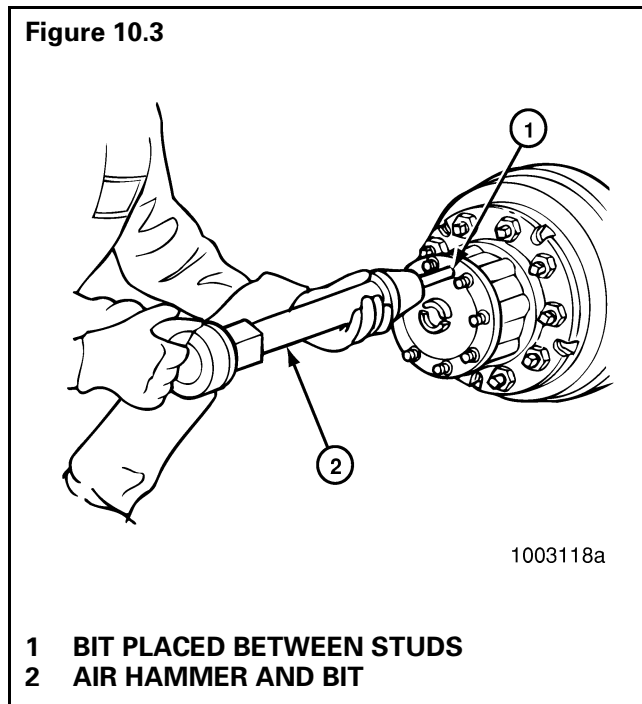

- Identify each axle shaft that is removed from the axle assembly so they can be installed in the same location after transporting or repair is completed. (Example: Match mark a mating axle shaft and hub.)
- Remove the tapered dowels, gasket (if used) and the axle shaft from the axle assembly. **Figure 10.1**.

Section 10

Vehicle Towing Instructions

11. Disconnect the air hose from the shift cylinder.
Figure 10.4.

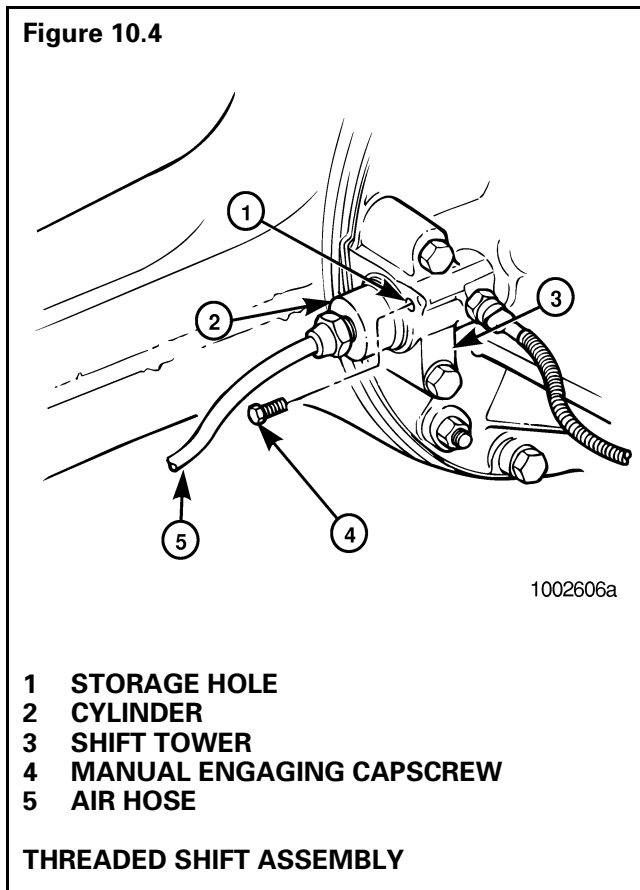

12. Remove the manual engaging capscREW from the storage hole. The storage hole of threaded shift assemblies is located in the shift tower of the carrier, next to the cylinder. Figure 10.4.
13. Lock (engage) the main differential using the Manual Engaging Method.

14. Manual Engaging Method:

- a. Install the manual engaging capscREW into the threaded hole in the center of the cylinder. Figure 10.5.

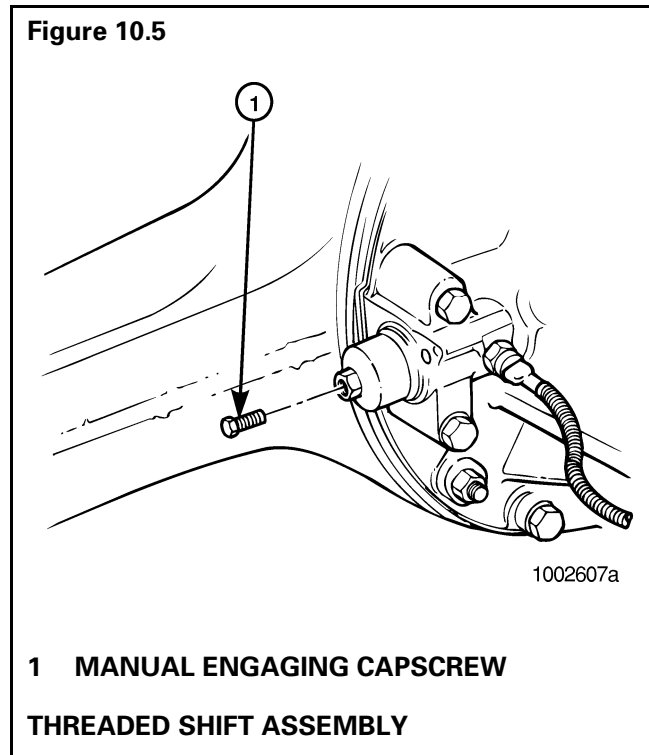

CAUTION

When you turn the capscREW in step b and you feel a high resistance, STOP TURNING THE CAPSCREW. A high resistance against the capscREW indicates that the splines of the shift collar and differential case are not aligned. Damage to the threads of the cylinder and capscREW will result. To align the splines, continue with steps c, d and e.

- b. Turn the capscREW to the right until the head is approximately 0.25 to 0.50 inch (6.4-12.7 mm) from the cylinder. The capscREW is now in the service position and the main differential is locked (engaged). Figure 10.6. When turning the capscREW you will feel a small amount of resistance. This is normal. If you feel a high resistance before achieving the 0.25 to 0.50 inch distance between the capscREW head and cylinder, **stop turning the capscREW** and continue with steps c, d and e.

Section 10

Vehicle Towing Instructions

Figure 10.6

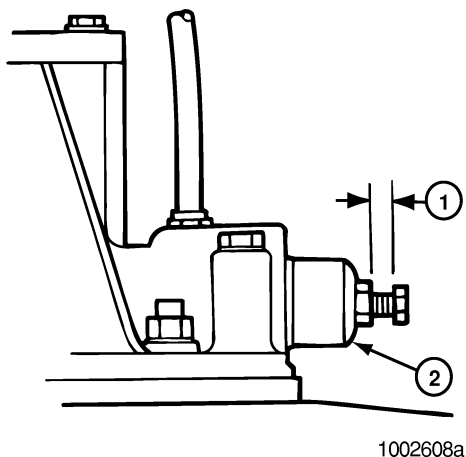

- 1 0.25" TO 0.50" (6.4 TO 12.7 MM)
2 CYLINDER

- c. Rotate the main driveline or the IAD a small amount by hand.
 - d. Turn the manual engaging capscrew again to the right. If you still feel a high resistance, **stop turning the capscrew.**
 - e. Repeat steps c and d until you feel a low resistance on the capscrew. Continue with step b.
15. Remove the remaining axle shaft(s) from the axle(s) that will remain on the road when the vehicle is transported. Follow steps 5 through 8 starting with "Before Towing or Drive-Away."
 16. Install a cover over the open end of each hub where an axle shaft was removed. This will prevent dirt from entering the bearing cavity and loss of lubricant.

NOTE

If an air supply will be used for the brake system of the transported vehicle, continue with steps 17 and 18, otherwise continue with step 19.

17. Connect an auxiliary air supply to the brake system of the vehicle that is being transported. Before moving the vehicle, charge the brake system with the correct amount of air pressure to operate the brakes. Refer to the instructions, supplied by the manufacturer of the vehicle for procedures and specifications. If an auxiliary air supply is not used, continue with step 19.

18. When the correct amount of air pressure is in the brake system, release the parking brakes of the vehicle that is being transported. Step 19 is not required.

WARNING

When you work on a spring chamber, carefully follow the service instructions of the chamber manufacturer. Sudden release of a compressed spring can cause serious personal injury.

19. If there are spring (parking) brakes on the axle(s) that will remain on the road when the vehicle is transported, and they cannot be released by air pressure, manually compress and lock each spring so that the brakes are released. Refer to the manufacturer's instructions.

After Towing or Drive-Away

WARNINGS

 **To prevent serious eye injury, always wear safe eye protection when you perform vehicle maintenance or service.**

 **Engage the parking brake to prevent the vehicle from moving before you begin maintenance or service procedures that require you to be under the vehicle. Serious personal injury can result.**

1. If an auxiliary air supply was used, apply the vehicle parking brakes using the switch inside the cab of the vehicle. If an auxiliary air supply was not used, begin with step 2.

WARNING

When you work on a spring chamber, carefully follow the service instructions of the chamber manufacturer. Sudden release of a compressed spring can cause serious personal injury.

2. Apply the vehicle spring (parking) brakes by manually releasing each spring that was compressed before transporting started. Refer to manufacturer's instructions.
3. Disconnect the auxiliary air supply, if used, from the brake system of the vehicle that was transported. Connect the vehicle's air supply to the brake system.
4. Remove the covers from the hubs.

Section 10

Vehicle Towing Instructions

Table M

<p>Single Axles</p> <p>Install the right-hand (curb side) axle shaft</p>
<p>Tandem Axles</p> <p>Forward Axle:</p> <p>Install the left-hand (road side) axle shaft</p> <p>Rear Axle:</p> <p>Install the right-hand (curb side) axle shaft</p>

NOTE

Install only the axle shaft(s) shown in Table M at this time. These axle shafts have a double row of splines that engage with splines of the side gear and shift collar in the main differential. Figure 10.7. Continue with step 5 of "After Towing or Drive-Away."

Fastener	Thread Size	Torque Value lb-ft (N•m) 
Capscrews:	0.31"-24	18-24 (24-33)
	0.50"-13	85-115 (115-156)
Stud Nuts: (plain nuts)	0.44"-20	50-75 (68-102)
	0.50"-20	75-115 (102-156)
	0.56"-18	110-165 (149-224)
	0.62"-18	150-230 (203-312)
	0.75"-16	310-400 (420-542)
(lock nut)	0.44"-20	40-65 (54-88)
	0.50"-20	65-100 (88-136)
	0.56"-18	100-145 (136-197)
	0.62"-18	130-190 (176-258)
	0.75"-16	270-350 (366-475)

5. Install the gasket, if used, and axle shaft into the axle housing and carrier in the same location it was removed from. The gasket and flange of the axle shaft must be flat against the hub. Rotate the axle shaft and/or the driveline as necessary to align the splines and the holes in the flange with the studs in the hub. **Figure 10.1.**
6. Install the dowels, if used, over each stud and into the tapered holes of the flange.
7. Install the washers and capscrews or stud nuts. Determine the size of the fasteners and tighten the capscrews or nuts to the corresponding torque value shown in the following table.

Section 10

Vehicle Towing Instructions

Figure 10.7

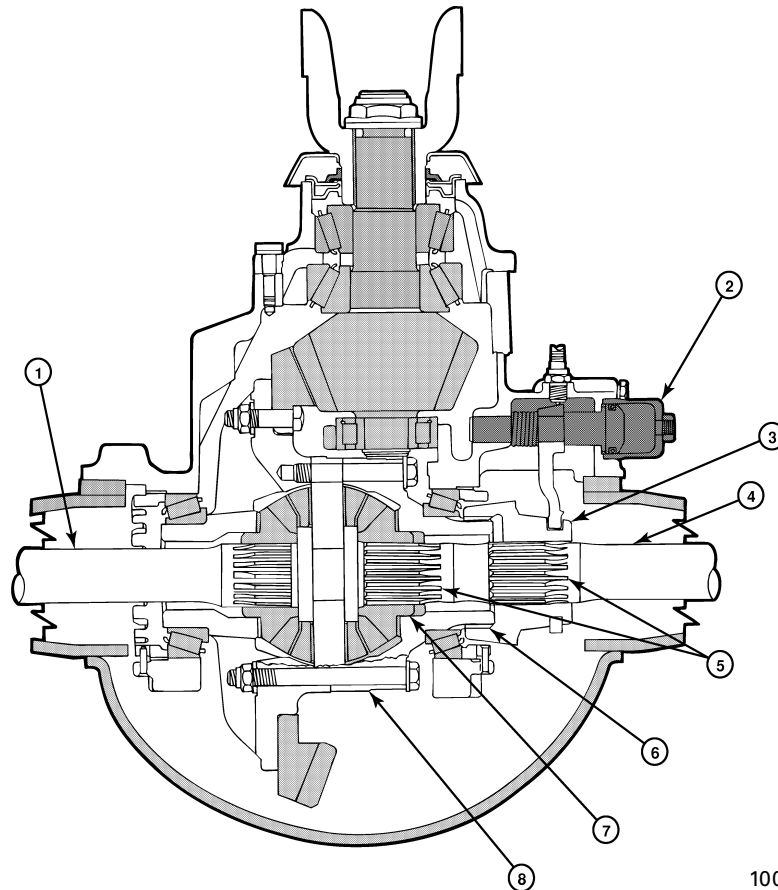

1002609a

- 1 LEFT-HAND (ROAD SIDE) AXLE SHAFT
- 2 SHIFT ASSEMBLY
- 3 SHIFT COLLAR
- 4 RIGHT-HAND (CURB SIDE) AXLE SHAFT
- 5 DOUBLE ROW OF SPLINES
- 6 SHIFT COLLAR AND DIFFERENTIAL CASE SPLINES ENGAGED (LOCKED)
- 7 SIDE GEAR
- 8 DIFFERENTIAL CASE

SINGLE AXLE OR REAR AXLE OF TANDEM SHOWN WITH SCREW-IN SHIFT ASSEMBLY AND IN THE LOCKED (ENGAGED) POSITION

8. Unlock (disengage) the DCDL by removing the manual engaging capscrew from the shift assembly.
9. Install the manual engaging capscrew into the storage hole. The storage hole of threaded shift assemblies is located in the shift tower of the carrier next to the cylinder. Tighten to 15 to 25 lb-ft (20-35 N•m). **T**
10. Connect the air hose to the shift cylinder. Tighten to 22 to 30 lb-ft (30-40 N•m). **T**
11. Install the remaining axle shaft into the axle housing and carrier. Follow steps 5 through 7.
12. Check the lubricant level in the axles and hubs where the axle shafts were removed. Add the correct type and amount of lubricant if necessary. For information about lubrication, refer to Maintenance Manual 1, *Lubrication*, or refer to the Lubrication Section of the Maintenance Manual for the axle model you are working with.

Section 10

Vehicle Towing Instructions

TYPE OF AXLE:

These instructions are for vehicles equipped with RICO single or tandem rear drive axles.

- **SINGLE AXLE, with Driver Controlled Main Differential Lock (DCDL — Bolt-On shift assembly)**
- **TANDEM AXLE, with Driver Controlled Main Differential Lock (DCDL — Bolt-On shift assembly) and with Inter-Axle Differential (IAD)**

The instructions supersede all other instructions for the purpose of transporting vehicles for service or new vehicle drive-away dated before April 1995, including those contained in RICO Maintenance Manuals.

When transporting a vehicle with the wheels of one or both drive axles on the road, it is possible to damage the axles if the wrong procedure is used before transporting begins. RICO recommends that you use the following procedure.

CAUTION

If the vehicle is equipped with a front drive axle, tow the vehicle from the front, with the front wheels off the ground. If this is not possible, you must remove the front drive shaft before towing.

Before Towing or Drive-Away

WARNINGS

 *To prevent serious eye injury, always wear safe eye protection when you perform vehicle maintenance or service.*

 *Engage the parking brake to prevent the vehicle from moving before you begin maintenance or service procedures that require you to be under the vehicle. Serious personal injury can result.*

1. Apply the vehicle parking brakes using the switch inside the cab of the vehicle.
2. Shift the transmission into neutral and start the vehicle's engine.
3. Shift the DCDL and the IAD to the unlocked (disengaged) positions using the switches inside the cab of the vehicle. The indicator lights in the cab will go off.
4. Stop the engine.

Table N

Single Axles
Remove the left-hand (road side) axle shaft
Tandem Axles
Forward Axle:
Remove the right-hand (curb side) axle shaft
Rear Axle:
Remove the left-hand (road side) axle shaft

NOTE

Remove only the axle shaft(s), shown in Table N at this time, from the axle(s) that will remain on the road when the vehicle is transported. Continue with step 5.

5. Remove the stud nuts or capscrews and the washers from the flange of the axle shaft. **Figure 10.8.**

CAUTION

Do not use a chisel or wedge to loosen the axle shaft and tapered dowels. Using a chisel or wedge can result in damage to the axle shaft, the gasket and seal, and/or the axle hub.

6. Loosen the tapered dowels, if used, in the flange of the axle shaft using one of the two following methods. **Figure 10.8.**

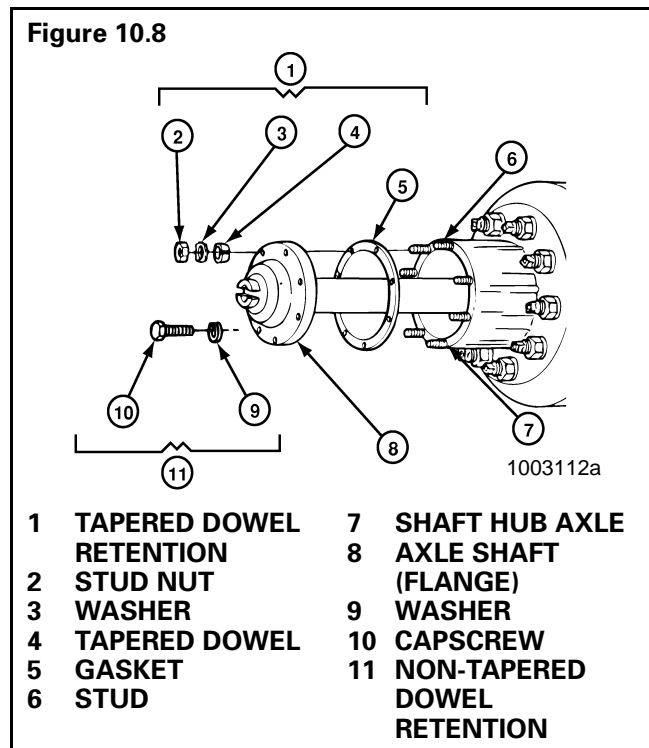

Section 10

Vehicle Towing Instructions

7. Brass Drift Method:

WARNING

Do not strike the round driving lugs on the flange of an axle shaft. Pieces can break off and cause serious personal injury.

NOTE

A 1.5 inch (38.1 mm) diameter brass hammer can be used as a drift.

- a. Hold a 1.5 inch (38.1 mm) diameter brass drift against the center of the axle shaft flange, *inside the round driving lugs*. **Figure 10.9.**

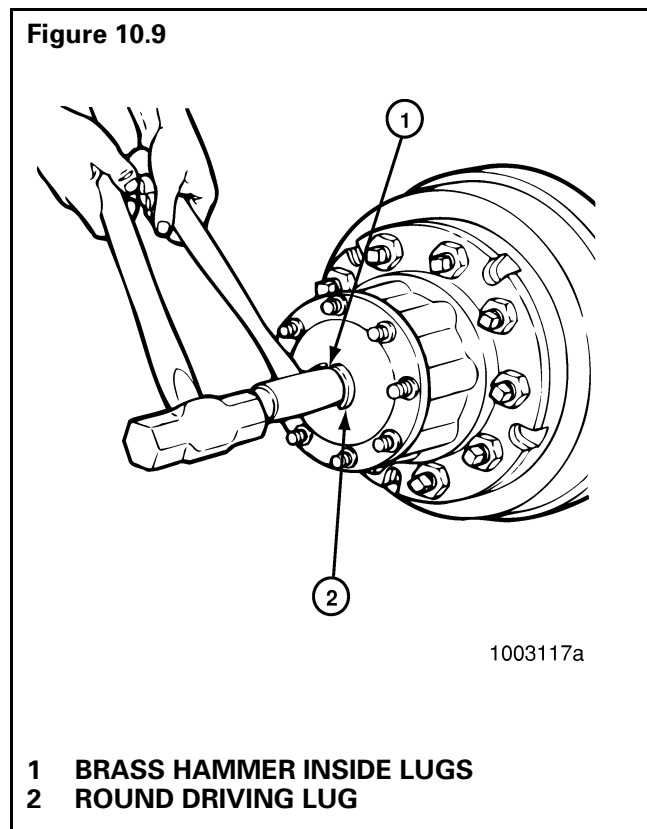

- b. Hit the end of the drift with a large hammer (5 to 6 pounds, 2.3 to 2.7 kg) to loosen the axle shaft and tapered dowels from the hub. **Figure 10.9.**

8. Air Hammer Method:

WARNING

Wear safe eye protection when using an air hammer. Power tools and components can loosen and break and cause serious personal injury.

- a. Use an air hammer, such as Chicago Pneumatic CP-4181-PULER, or equivalent, with a round hammer bit to loosen the axle shaft and dowels.
- b. Place the round hammer bit against the axle shaft flange between the studs, at different points around the flange. Operate the air hammer at each location and loosen the axle shaft and tapered dowels from the hub. **Figure 10.10.**

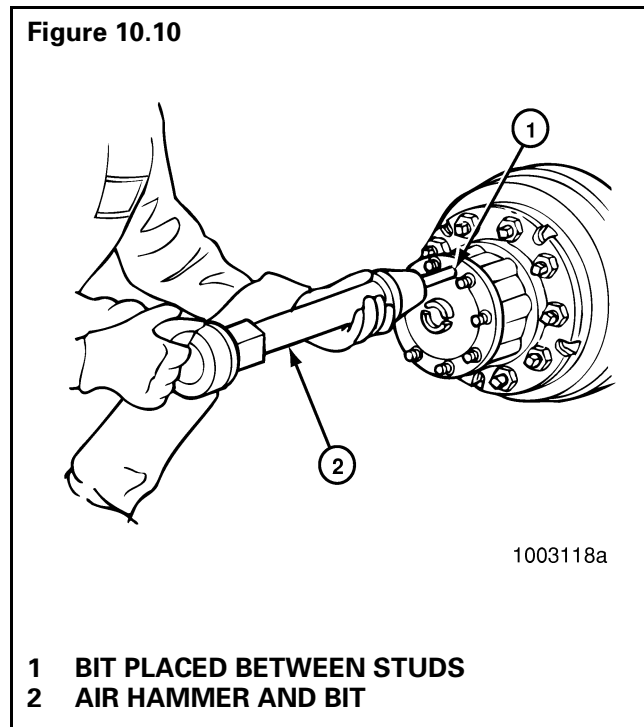

9. Identify each axle shaft that is removed from the axle assembly so they can be installed in the same location after transporting or repair is completed. (Example: Match mark a mating axle shaft and hub.)
10. Remove the tapered dowels, gasket (if used) and the axle shaft from the axle assembly. **Figure 10.11.**

Section 10

Vehicle Towing Instructions

11. Remove the manual engaging capscrew from the storage hole. The storage hole of bolted-on shift assemblies is located in the top side of the shift cylinder cover. **Figure 10.11.**

Figure 10.11

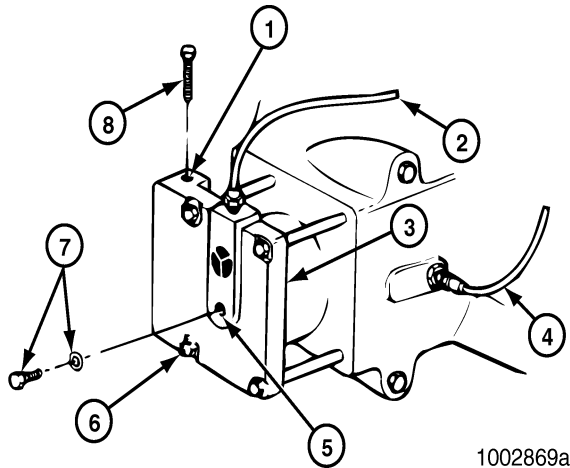

- 1 TOP STORAGE HOLE FOR MANUAL ENGAGING CAPSCREW
- 2 AIR LINE
- 3 CYLINDER COVER
- 4 WIRE
- 5 SERVICE POSITION CAPSCREW HOLE
- 6 BOTTOM STORAGE HOLE FOR PLUG AND GASKET
- 7 PLUG AND GASKET
- 8 MANUAL ENGAGING CAPSCREW

BOLT-ON SHIFT ASSEMBLY

12. Remove the plug and gasket from the center of the shift cylinder cover. Install the plug and gasket into the bottom side storage hole of the shift cylinder cover (opposite end of the storage hole for the manual engaging capscrew). Tighten to 15 to 25 lb-ft (20-35 N•m) torque. **Figure 10.11.** 
13. Lock (engage) the main differential using one of the two following methods: Air Pressure Method or Manual Engaging Method.

14. Air Pressure Method:

- a. Install the manual engaging capscrew into the threaded hole in the center of the cylinder cover. Turn the capscrew to the right 3 to 5 turns. **Figure 10.12.**
- b. Shift the transmission into neutral and start the vehicle's engine. Let the engine idle to increase the pressure in the air system. **Do not release the parking brakes.**
- c. Shift the main differential to the locked (engaged) position using the switch inside the cab of the vehicle. When the differential is locked, the indicator light in the cab will go on. If the light does not go on it will be necessary to rotate the main driveline or the IAD by hand until the main differential is locked and the indicator light goes on.
- d. While the differential is held in the locked position by air pressure, turn the manual engaging capscrew to the right until you feel resistance against the piston. **Stop turning the capscrew.**
- e. Place the main differential lock switch in the unlocked (disengaged) position.

NOTE

When the shift collar is completely engaged with the splines of the main differential case, the differential is locked and the driveline cannot be rotated. Figure 10.14.

- f. Stop the engine. Continue with step 16.

Section 10

Vehicle Towing Instructions

15. Manual Engaging Method:



CAUTION

When you turn the capscrew in step b and you feel a high resistance, **STOP TURNING THE CAPSCREW**. A high resistance against the capscrew indicates that the splines of the shift collar and differential case are not aligned. Damage to the threads of the cylinder cover and capscrew will result. To align the splines, continue with steps c, d and e.

- Install the manual engaging capscrew into the threaded hole in the center of the cylinder cover. **Figure 10.12**.

Figure 10.12

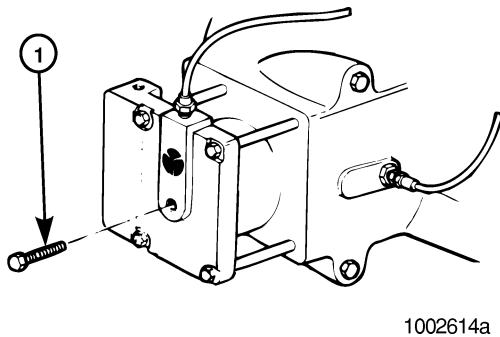

1 MANUAL ENGAGING CAPSCREW

BOLT-ON SHIFT ASSEMBLY

- Turn the capscrew to the right until the head is approximately 0.25 to 0.50 inch (6.4-12.7 mm) from the cylinder cover. The capscrew is now in the service position and the main differential is locked (engaged). **Figure 10.13**. When turning the capscrew you will feel a small amount of resistance. This is normal. If you feel a high resistance before achieving the 0.25 to 0.50 inch distance between the capscrew head and cylinder, **stop turning the capscrew** and continue with steps c, d and e.

Figure 10.13

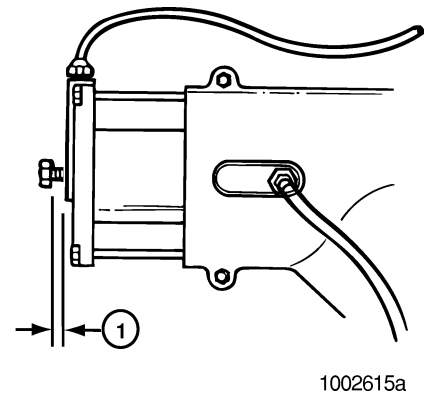

1 0.25" TO 0.50" (6.4-12.7 MM)

- Rotate the main driveline or the IAD a small amount by hand.
 - Turn the manual engaging capscrew again to the right. If you still feel a high resistance, **stop turning the capscrew**.
 - Repeat steps c and d until you feel a low resistance on the capscrew. Continue with step b.
- Remove the remaining axle shaft(s) from the axle(s) that will remain on the road when the vehicle is transported. Follow steps 5 through 8 starting with "Before Towing or Drive-Away."
 - Install a cover over the open end of each hub where an axle shaft was removed. This will prevent dirt from entering the bearing cavity and loss of lubricant.

Section 10

Vehicle Towing Instructions

NOTE

If an air supply will be used for the brake system of the transported vehicle, continue with steps 18 and 19. Otherwise continue with step 20.

18. Connect an auxiliary air supply to the brake system of the vehicle that is being transported. Before moving the vehicle, charge the brake system with the correct amount of air pressure to operate the brakes. Refer to the instructions supplied by the manufacturer of the vehicle for procedures and specifications. If an auxiliary air supply is not used, continue with step 20.
19. When the correct amount of air pressure is in the brake system, release the parking brakes of the vehicle that is being transported. Step 20 is not required.

WARNING

When you work on a spring chamber, carefully follow the service instructions of the chamber manufacturer. Sudden release of a compressed spring can cause serious personal injury.

20. If there are spring (parking) brakes on the axle(s) that will remain on the road when the vehicle is transported, and they cannot be released by air pressure, manually compress and lock each spring so that the brakes are released. Refer to the manufacturer's instructions.

After Towing or Drive-Away

WARNINGS

 *To prevent serious eye injury, always wear safe eye protection when you perform vehicle maintenance or service.*

 *Engage the parking brake to prevent the vehicle from moving before you begin maintenance or service procedures that require you to be under the vehicle. Serious personal injury can result.*

1. If an auxiliary air supply was used, apply the vehicle parking brakes using the switch inside the cab of the vehicle. If an auxiliary air supply was not used, begin with step 2.

WARNING

When you work on a spring chamber, carefully follow the service instructions of the chamber manufacturer. Sudden release of a compressed spring can cause serious personal injury.

2. Apply the vehicle spring (parking) brakes by manually releasing each spring that was compressed before transporting started. Refer to manufacturer's instructions.

Section 10

Vehicle Towing Instructions

Figure 10.14

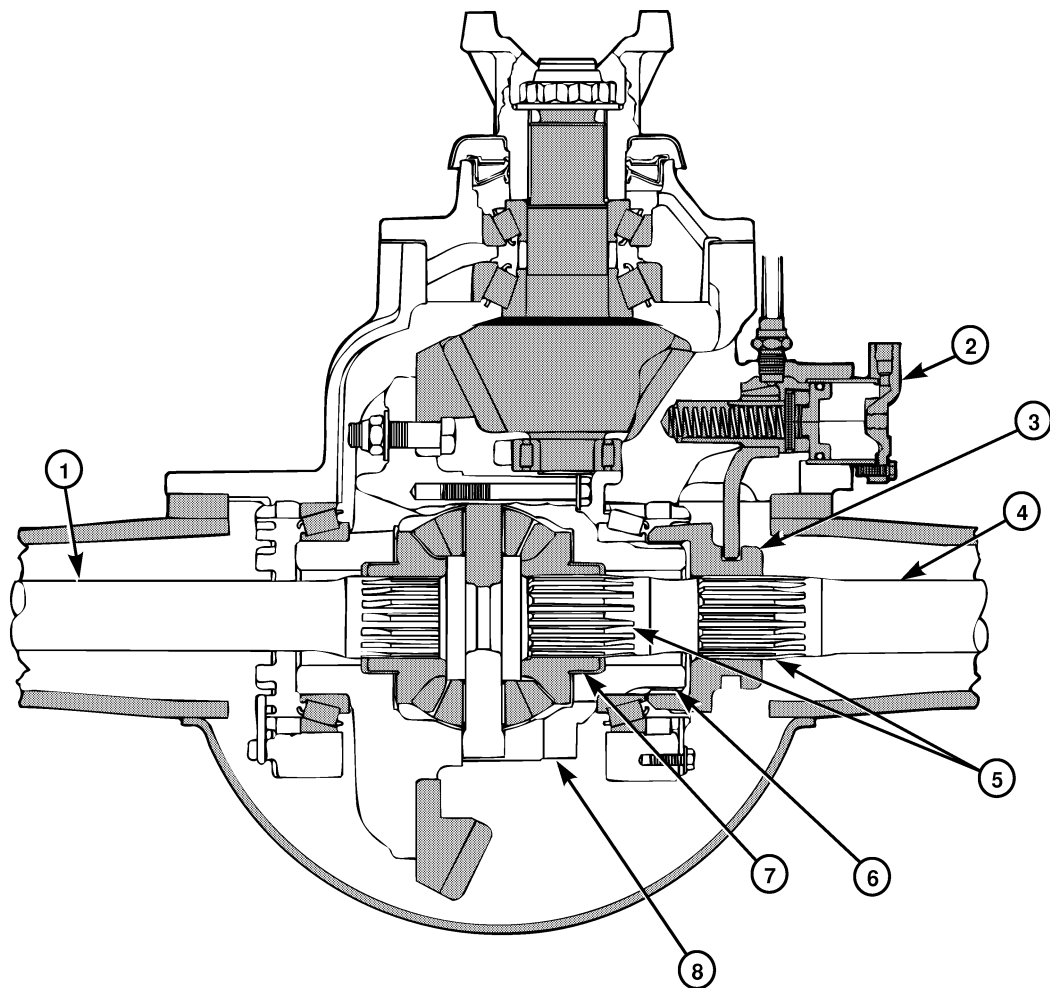

1002616a

- 1 LEFT-HAND (ROAD SIDE) AXLE SHAFT
- 2 SHIFT ASSEMBLY
- 3 SHIFT COLLAR
- 4 RIGHT-HAND (CURB SIDE) AXLE SHAFT
- 5 DOUBLE ROW OF SPLINES
- 6 SHIFT COLLAR AND DIFFERENTIAL CASE SPLINES ENGAGED (LOCKED)
- 7 SIDE GEAR
- 8 DIFFERENTIAL CASE

SINGLE AXLE OR REAR AXLE OF TANDEM SHOWN WITH BOLTED-ON SHIFT ASSEMBLY AND SHOWN IN THE LOCKED (ENGAGED) POSITION

3. Disconnect the auxiliary air supply, if used, from the brake system of the vehicle that was transported. Connect the vehicle's air supply to the brake system.
4. Remove the covers from the hubs.

Section 10

Vehicle Towing Instructions

Table O



Single Axles Install the right-hand (curb side) axle shaft
Tandem Axles Forward Axle: Install the left-hand (road side) axle shaft Rear Axle: Install the right-hand (curb side) axle shaft

NOTE

Install only the axle shaft(s) shown in Table O at this time. These axle shafts have a double row of splines that engage with splines of the side gear and shift collar in the main differential. Continue with step 5. Figure 10.14.

5. Install the gasket, if used, and axle shaft into the axle housing and carrier in the same location it was removed from. The gasket and flange of the axle shaft must be flat against the hub. Rotate the axle shaft and/or the driveline as necessary to align the splines and the holes in the flange with the studs in the hub. **Figure 10.8.**
6. Install the dowels, if used, over each stud and into the tapered holes of the flange.
7. Install the washers and capscrews or stud nuts. Determine the size of the fasteners and tighten the capscrews or nuts to the corresponding torque value shown in the table below.

Fastener	Thread Size	Torque Value lb-ft (N•m) 
Capscrews:	0.31"-24	18-24 (24-33)
	0.50"-13	85-115 (115-156)
Stud Nuts: (plain nuts)	0.44"-20	50-75 (68-102)
	0.50"-20	75-115 (102-156)
	0.56"-18	110-165 (149-224)
	0.62"-18	150-230 (203-312)
	0.75"-16	310-400 (420-542)
(lock nut)	0.44"-20	40-65 (54-88)
	0.50"-20	65-100 (88-136)
	0.56"-18	100-145 (136-197)
	0.62"-18	130-190 (176-258)
	0.75"-16	270-350 (366-475)

8. Unlock (disengage) the DCDL by removing the manual engaging capscrew from the shift assembly.
9. Install the manual engaging capscrew into the storage hole. The storage hole of bolted-on shift assemblies is located in the top side of the shift cylinder cover. Tighten to 15 to 25 lb-ft (20-35 N•m). **Figure 10.11.** 
10. Remove the plug and gasket from the storage hole. Install the plug and gasket into the threaded hole in the center of the shift cylinder cover. Tighten from 15 to 25 lb-ft (25-30 N•m). 
11. Install the remaining axle shaft into the axle housing and carrier. Follow steps 5 through 7 of "After Towing or Drive-Away."
12. Check the lubricant level in the axles and hubs where the axle shafts were removed. Add the correct type and amount of lubricant if necessary. For information about lubrication, refer to Maintenance Manual 1, *Lubrication*, or refer to the Lubrication Section of the Maintenance Manual for the axle model you are working with.

Section 10

Vehicle Towing Instructions

TYPE OF AXLE:

These instructions are for vehicles equipped with RICO single or tandem rear drive axles.

- **SINGLE AXLE, without Driver Controlled Main Differential Lock (DCDL)**
- **TANDEM AXLE, without Driver Controlled Main Differential Lock (DCDL), with Inter-Axle Differential (IAD)**

The instructions supersede all other instructions for the purpose of transporting vehicles for service or new vehicle drive-away dated before April 1995, including those contained in RICO Maintenance Manuals.

When transporting a vehicle with the wheels of one or both drive axles on the road, it is possible to damage the axles if the wrong procedure is used before transporting begins. RICO recommends that you use the following procedure.

CAUTION

If the vehicle is equipped with a front drive axle, tow the vehicle from the front, with the front wheels off the ground. If this is not possible, you must remove the front drive shaft before towing.

Before Towing or Drive-Away

WARNINGS

 *To prevent serious eye injury, always wear safe eye protection when you perform vehicle maintenance or service.*

 *Engage the parking brake to prevent the vehicle from moving before you begin maintenance or service procedures that require you to be under the vehicle. Serious personal injury can result.*

1. Apply the vehicle parking brakes using the switch inside the cab of the vehicle.

NOTE

Single Axle continue with step 5. Tandem Axle continue with step 2.

2. Shift the transmission into neutral and start the vehicle's engine.
3. Shift the IAD to the unlocked (disengaged) position using the switch inside the cab of the vehicle. The indicator light in the cab will go off.
4. Stop the engine.

NOTE

Remove both axle shafts from the axle(s) that will remain on the road when the vehicle is transported. Continue with step 5 for both axle shafts.

5. Remove the stud nuts or capscrews and the washers from the flange of the axle shaft. Figure 10.15.

CAUTION

Do not use a chisel or wedge to loosen the axle shaft and tapered dowels. Using a chisel or wedge can result in damage to the axle shaft, the gasket and seal, and/or the axle hub.

6. Loosen the tapered dowels, if used, in the flange of the axle shaft using one of the two following methods. Figure 10.15.

Figure 10.15

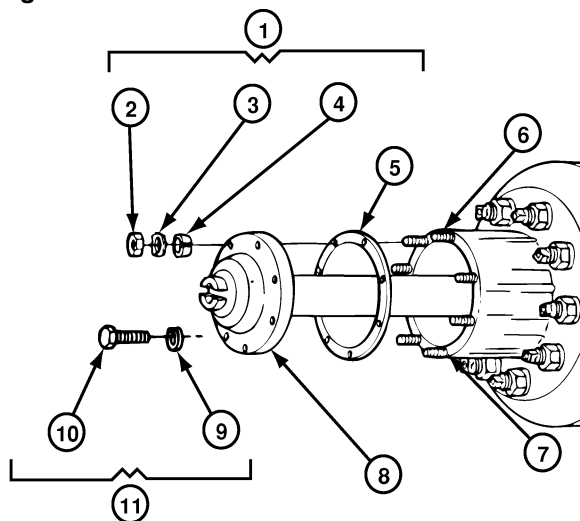

1003112a

- 1 TAPERED DOWEL RETENTION
- 2 STUD NUT
- 3 WASHER
- 4 TAPERED DOWEL
- 5 GASKET
- 6 STUD
- 7 SHAFT HUB AXLE
- 8 AXLE SHAFT (FLANGE)
- 9 WASHER
- 10 CAPSCREW
- 11 NON-TAPERED DOWEL RETENTION

Section 10

Vehicle Towing Instructions

NOTE

A 1.5 inch (38.1 mm) diameter brass hammer can be used as a drift.

7. Brass Drift Method:



WARNING

Do not strike the round driving lugs on the flange of an axle shaft. Pieces can break off and cause serious personal injury.

- a. Hold a 1.5 inch (38.1 mm) diameter brass drift against the center of the axle shaft flange, **inside the round driving lugs**. Figure 10.16.

Figure 10.16

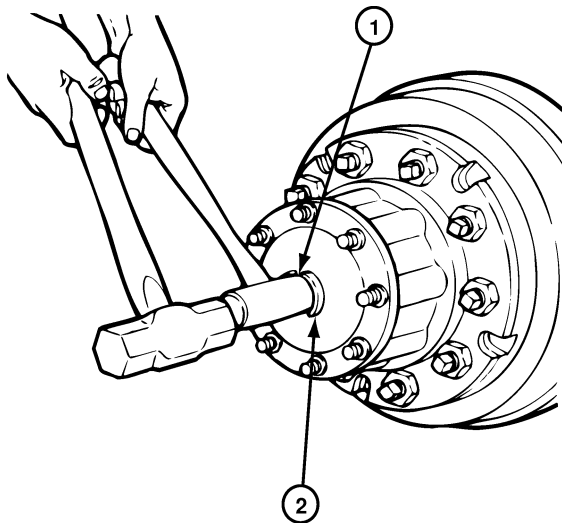

1003117a

- 1 BRASS HAMMER INSIDE LUGS
- 2 ROUND DRIVING LUG

- b. Hit the end of the drift with a large hammer (5 to 6 lbs, 2 to 3 kg) to loosen the axle shaft and tapered dowels from the hub. Figure 10.16.

8. Air Hammer Vibration Method:



WARNING

Wear safe eye protection when using an air hammer. Power tools and components can loosen and break and cause serious personal injury.

- a. Use an air hammer, such as Chicago Pneumatic CP-4181-PULER, or equivalent, with a round hammer bit to loosen the axle shaft and dowels.
- b. Place the round hammer bit against the axle shaft flange between the studs, at different points around the flange. Operate the air hammer at each location and loosen the axle shaft and tapered dowels from the hub. Figure 10.17.

Figure 10.17

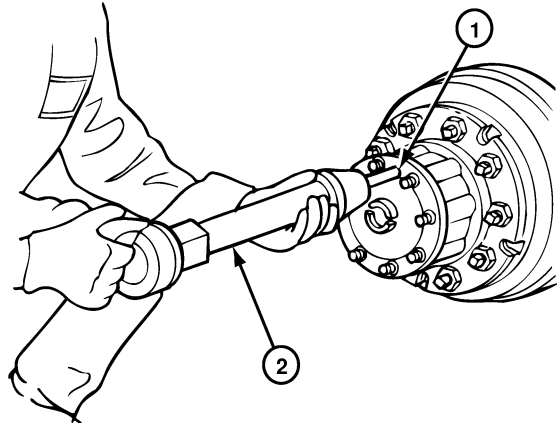

1003118a

- 1 BIT PLACED BETWEEN STUDS
- 2 AIR HAMMER AND BIT

9. Identify each axle shaft that is removed from the axle assembly so they can be installed in the same location after transporting or repair is completed. (Example: Match mark a mating axle shaft and hub.)
10. Remove the tapered dowels, gasket (if used) and the axle shaft from the axle assembly. Figure 10.15.
11. Install a cover over the open end of each hub where an axle shaft was removed. This will prevent dirt from entering the bearing cavity and loss of lubricant.

Section 10

Vehicle Towing Instructions

NOTE

If an air supply will be used for the brake system of the transported vehicle, continue with steps 12 and 13, otherwise continue with step 14.

12. Connect an auxiliary air supply to the brake system of the vehicle that is being transported. Before moving the vehicle, charge the brake system with the correct amount of air pressure to operate the brakes. Refer to the instructions supplied by the manufacturer of the vehicle for procedures and specifications. If an auxiliary air supply is not used, continue with step 14.
13. When the correct amount of air pressure is in the brake system, release the parking brakes of the vehicle that is being transported. Step 14 is not required.



WARNING

When you work on a spring chamber, carefully follow the service instructions of the chamber manufacturer. Sudden release of a compressed spring can cause serious personal injury.

14. If there are spring (parking) brakes on the axle(s) that will remain on the road when the vehicle is transported, and they cannot be released by air pressure, manually compress and lock each spring so that the brakes are released. Refer to the manufacturer's instructions.

After Towing or Drive-Away

WARNINGS

⚠ To prevent serious eye injury, always wear safe eye protection when you perform vehicle maintenance or service.

⚠ Engage the parking brake to prevent the vehicle from moving before you begin maintenance or service procedures that require you to be under the vehicle. Serious personal injury can result.

1. If an auxiliary air supply was used, apply the vehicle parking brakes using the switch inside the cab of the vehicle. If an auxiliary air supply was not used, begin with step 2.



WARNING

When you work on a spring chamber, carefully follow the service instructions of the chamber manufacturer. Sudden release of a compressed spring can cause serious personal injury.

2. Apply the vehicle spring (parking) brakes by manually releasing each spring that was compressed before transporting started. Refer to manufacturer's instructions.

3. Disconnect the auxiliary air supply, if used, from the brake system of the vehicle that was transported. Connect the vehicle's air supply to the brake system.
4. Remove the covers from the hubs.

NOTE

Continue with steps 5 through 7 to install all axle shafts.

5. Install the gasket, if used, and axle shaft into the axle housing and carrier in the same location it was removed from. The gasket and flange of the axle shaft must be flat against the hub. Rotate the axle shaft and/or the driveline as necessary to align the splines and the holes in the flange with the studs in the hub. **Figure 10.15.**
6. Install the dowels, if used, over each stud and into the tapered holes of the flange.
7. Install the washers and capscrews or stud nuts. Determine the size of the fasteners and tighten the capscrews or nuts to the corresponding torque value shown in the table below.
8. Check the lubricant level in the axles and hubs where the axle shafts were removed. Add the correct type and amount of lubricant if necessary. For information about lubrication, refer to Maintenance Manual 1, *Lubrication*, or refer to the Lubrication Section of the Maintenance Manual for the axle model you are working with.

Fastener	Thread Size	Torque Value lb-ft (N·m)
Capscrews:	0.31"-24	18-24 (24-33)
	0.50"-13	85-115 (115-156)
Stud Nuts: (plain nuts)	0.44"-20	50-75 (68-102)
	0.50"-20	75-115 (102-156)
	0.56"-18	110-165 (149-224)
	0.62"-18	150-230 (203-312)
	0.75"-16	310-400 (420-542)
(lock nut)	0.44"-20	40-65 (54-88)
	0.50"-20	65-100 (88-136)
	0.56"-18	100-145 (136-197)
	0.62"-18	130-190 (176-258)
	0.75"-16	270-350 (366-475)

Planetary Axle Wheel Ends

Coverless Planetary Spider Design

Maintenance Manual 9G

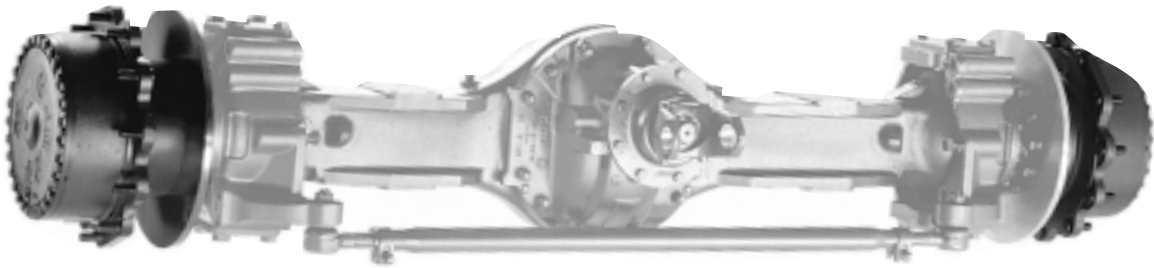

Service Notes

Before You Begin

This manual provides maintenance and service procedures for RICO coverless planetary spider design wheel end assemblies. Before you begin procedures:

1. Read and understand all instructions and procedures before you begin to service components.
2. Read and observe all Caution and Warning safety alerts that precede instructions or procedures you will perform. These alerts help to avoid damage to components, serious personal injury, or both.
3. Follow your company's maintenance and service, installation, and diagnostics guidelines.
4. Use special tools when required to help avoid serious personal injury and damage to components.

Safety Alerts, Torque Symbol and Notes



 WARNING	A Warning alerts you to an instruction or procedure that you must follow exactly to avoid serious personal injury and damage to components.
 CAUTION	A Caution alerts you to an instruction or procedure that you must follow exactly to avoid damage to components and possible serious personal injury can also occur.
	The torque symbol alerts you to tighten fasteners to a specified torque value.
NOTE:	A Note provides information or suggestions that help you correctly service a component.

Table of Contents

 Asbestos and Non-Asbestos Fibers Warnings	iii
Section 1: Exploded View	
Coverless Planetary Wheel-End	1
Drum Brake and Disc Brake Assemblies	2
Section 2: Introduction	
Description	3
Identification	
Section 3: Disassembly	
Remove and Disassemble the Planetary Wheel Ends	5
Remove the Tires and Rims	
Remove the Planetary Spider Assembly	6
Disassemble the Planetary Spider Assembly	7
Remove the Ring Gear and Axle Shaft	
Prepare to Remove the Wheel Hub	8
Prepare to Remove the Ring Gear Hub and Wheel Hub	
Remove the Ring Gear Hub and Wheel Hub	9
Remove the Hub Oil Seal and Bearings	10
Remove the Brake Drum or Disc Brake Rotor	
Remove the Brake Shoes	
Remove the Spindle	
Section 4: Prepare Parts for Assembly	
Clean Ground or Polished Parts	13
Clean Parts With Rough Finishes	
Clean Axle Assemblies	
Dry Cleaned Parts	
Prevent Corrosion	
Inspect Parts	
Inspect Tapered Roller Bearings	14
Inspect Planetary Wheel End Components	15
Repair or Replace Parts	
Repair Welding	
Remove Capscrews Fastened with Liquid Adhesive	
Cleaning	16
Using Dri-Loc Fasteners and RICO Liquid Adhesive	
Reusing Dri-Loc Fasteners and Loctite® No. 277	
Applying Silicone Gasket Material	17
Flush Lube From the Axle	

Table of Contents

Section 5: Assembly

Install the Spindle	19
Install the Axle Shaft in Rigid Axle Models	22
Assemble the Ring Gear Hub Assembly	
Assemble the Hub, Bearings, Oil Seal and Drum or Rotor	
Install the Wheel Hub	23
Adjust the Wheel Bearing Preload	
Install the Planetary Ring Gear and Sun Gear	25
Assemble the Planetary Spider	
Install the Planetary Spider Assembly	27
Adjust the Brakes	28
Install the Tires and Rims	
Fill the Wheel Ends With Lubricant	
Measure and Adjust the Toe Setting	
Tire Matching for Tandem and Tridem Axles	29

Section 6: Lubrication

Lubrication Schedule	31
Lubricant Specifications	

Section 7: Specifications

Rigid Axle Wet Disc Brake	33
Rigid Axle Drum Brake	
Rigid Axle Dry Disc Brake	34
Steering Axle Dry Disc Brake	
Planetary Axle Wheel End Torque Specifications	35

Asbestos and Non-Asbestos Fibers



ASBESTOS FIBERS WARNING

The following procedures for servicing brakes are recommended to reduce exposure to asbestos fiber dust, a cancer and lung disease hazard. Material Safety Data Sheets are available from RICO.

Hazard Summary

Because some brake linings contain asbestos, workers who service brakes must understand the potential hazards of asbestos and precautions for reducing risks. Exposure to airborne asbestos dust can cause serious and possibly fatal diseases, including asbestosis (a chronic lung disease) and cancer, principally lung cancer and mesothelioma (a cancer of the lining of the chest or abdominal cavities). Some studies show that the risk of lung cancer among persons who smoke and who are exposed to asbestos is much greater than the risk for non-smokers. Symptoms of these diseases may not become apparent for 15, 20 or more years after the first exposure to asbestos.

Accordingly, workers must use caution to avoid creating and breathing dust when servicing brakes. Specific recommended work practices for reducing exposure to asbestos dust follow. Consult your employer for more details.

Recommended Work Practices

1. **Separate Work Areas.** Whenever feasible, service brakes in a separate area away from other operations to reduce risks to unprotected persons. OSHA has set a maximum allowable level of exposure for asbestos of 0.1 f/cc as an 8-hour time-weighted average and 1.0 f/cc averaged over a 30-minute period. Scientists disagree, however, to what extent adherence to the maximum allowable exposure levels will eliminate the risk of disease that can result from inhaling asbestos dust. OSHA requires that the following sign be posted at the entrance to areas where exposures exceed either of the maximum allowable levels:

**DANGER: ASBESTOS
CANCER AND LUNG DISEASE HAZARD
AUTHORIZED PERSONNEL ONLY
RESPIRATORS AND PROTECTIVE CLOTHING
ARE REQUIRED IN THIS AREA**

2. **Respiratory Protection.** Wear a respirator equipped with a high-efficiency (HEPA) filter approved by NIOSH or MSHA for use with asbestos at all times when servicing brakes, beginning with the removal of the wheels.

3. **Procedures for Servicing Brakes.**

- a. Enclose the brake assembly within a negative pressure enclosure. The enclosure should be equipped with a HEPA vacuum and worker arm sleeves. With the enclosure in place, use the HEPA vacuum to loosen and vacuum residue from the brake parts.
- b. As an alternative procedure, use a catch basin with water and a biodegradable, non-phosphate, water-based detergent to wash the brake drum or rotor and other brake parts. The solution should be applied with low pressure to prevent dust from becoming airborne. Allow the solution to flow between the brake drum and the brake support or the brake rotor and caliper. The wheel hub and brake assembly components should be thoroughly wetted to suppress dust before the brake shoes or brake pads are removed. Wipe the brake parts clean with a cloth.
- c. If an enclosed vacuum system or brake washing equipment is not available, employers may adopt their own written procedures for servicing brakes, provided that the exposure levels associated with the employer's procedures do not exceed the levels associated with the enclosed vacuum system or brake washing equipment. Consult OSHA regulations for more details.
- d. Wear a respirator equipped with a HEPA filter approved by NIOSH or MSHA for use with asbestos when grinding or machining brake linings. In addition, do such work in an area with a local exhaust ventilation system equipped with a HEPA filter.
- e. **NEVER** use compressed air by itself, dry brushing, or a vacuum not equipped with a HEPA filter when cleaning brake parts or assemblies. **NEVER** use carcinogenic solvents, flammable solvents, or solvents that can damage brake components as wetting agents.

4. **Cleaning Work Areas.** Clean work areas with a vacuum equipped with a HEPA filter or by wet wiping. **NEVER** use compressed air or dry sweeping to clean work areas. When you empty vacuum cleaners and handle used rags, wear a respirator equipped with a HEPA filter approved by NIOSH or MSHA for use with asbestos. When you replace a HEPA filter, wet the filter with a fine mist of water and dispose of the used filter with care.

5. **Worker Clean-Up.** After servicing brakes, wash your hands before you eat, drink or smoke. Shower after work. Do not wear work clothes home. Use a vacuum equipped with a HEPA filter to vacuum work clothes after they are worn. Launder them separately. Do not shake or use compressed air to remove dust from work clothes.

6. **Waste Disposal.** Dispose of discarded linings, used rags, cloths and HEPA filters with care, such as in sealed plastic bags. Consult applicable EPA, state and local regulations on waste disposal.

Regulatory Guidance

References to OSHA, NIOSH, MSHA, and EPA, which are regulatory agencies in the United States, are made to provide further guidance to employers and workers employed within the United States. Employers and workers employed outside of the United States should consult the regulations that apply to them for further guidance.



NON-ASBESTOS FIBERS WARNING

The following procedures for servicing brakes are recommended to reduce exposure to non-asbestos fiber dust, a potential cancer and lung disease hazard. Material Safety Data Sheets are available from RICO.

Hazard Summary

Most recently manufactured brake linings do not contain asbestos fibers. These brake linings may contain one or more of a variety of ingredients, including glass fibers, mineral wool, aramid fibers, ceramic fibers and silica that can present health risks if inhaled. Scientists disagree on the extent of the risks from exposure to these substances. Nonetheless, exposure to silica dust can cause silicosis, a non-cancerous lung disease. Silicosis gradually reduces lung capacity and efficiency and can result in serious breathing difficulty. Some scientists believe other types of non-asbestos fibers, when inhaled, can cause similar diseases of the lung. In addition, silica dust and ceramic fiber dust are known to the State of California to cause lung cancer. U.S. and international agencies have also determined that dust from mineral wool, ceramic fibers and silica are potential causes of cancer.

Accordingly, workers must use caution to avoid creating and breathing dust when servicing brakes. Specific recommended work practices for reducing exposure to non-asbestos dust follow. Consult your employer for more details.

Recommended Work Practices

1. **Separate Work Areas.** Whenever feasible, service brakes in a separate area away from other operations to reduce risks to unprotected persons.

2. **Respiratory Protection.** OSHA has set a maximum allowable level of exposure for silica of 0.1 mg/m³ as an 8-hour time-weighted average. Some manufacturers of non-asbestos brake linings recommend that exposures to other ingredients found in non-asbestos brake linings be kept below 1.0 f/cc as an 8-hour time-weighted average. Scientists disagree, however, to what extent adherence to these maximum allowable exposure levels will eliminate the risk of disease that can result from inhaling non-asbestos dust.

Therefore, wear respiratory protection at all times during brake servicing, beginning with the removal of the wheels. Wear a respirator equipped with a high-efficiency (HEPA) filter approved by NIOSH or MSHA, if the exposures levels may exceed OSHA or manufacturer's recommended maximum levels. Even when exposures are expected to be within the maximum allowable levels, wearing such a respirator at all times during brake servicing will help minimize exposure.

3. **Procedures for Servicing Brakes.**

- a. Enclose the brake assembly within a negative pressure enclosure. The enclosure should be equipped with a HEPA vacuum and worker arm sleeves. With the enclosure in place, use the HEPA vacuum to loosen and vacuum residue from the brake parts.
- b. As an alternative procedure, use a catch basin with water and a biodegradable, non-phosphate, water-based detergent to wash the brake drum or rotor and other brake parts. The solution should be applied with low pressure to prevent dust from becoming airborne. Allow the solution to flow between the brake drum and the brake support or the brake rotor and caliper. The wheel hub and brake assembly components should be thoroughly wetted to suppress dust before the brake shoes or brake pads are removed. Wipe the brake parts clean with a cloth.
- c. If an enclosed vacuum system or brake washing equipment is not available, carefully clean the brake parts in the open air. Wet the parts with a solution applied with a pump-spray bottle that creates a fine mist. Use a solution containing water, and, if available, a biodegradable, non-phosphate, water-based detergent. The wheel hub and brake assembly components should be thoroughly wetted to suppress dust before the brake shoes or brake pads are removed. Wipe the brake parts clean with a cloth.
- d. Wear a respirator equipped with a HEPA filter approved by NIOSH or MSHA when grinding or machining brake linings. In addition, do such work in an area with a local exhaust ventilation system equipped with a HEPA filter.
- e. **NEVER** use compressed air by itself, dry brushing, or a vacuum not equipped with a HEPA filter when cleaning brake parts or assemblies. **NEVER** use carcinogenic solvents, flammable solvents, or solvents that can damage brake components as wetting agents.

4. **Cleaning Work Areas.** Clean work areas with a vacuum equipped with a HEPA filter or by wet wiping. **NEVER** use compressed air or dry sweeping to clean work areas. When you empty vacuum cleaners and handle used rags, wear a respirator equipped with a HEPA filter approved by NIOSH or MSHA, to minimize exposure. When you replace a HEPA filter, wet the filter with a fine mist of water and dispose of the used filter with care.

5. **Worker Clean-Up.** After servicing brakes, wash your hands before you eat, drink or smoke. Shower after work. Do not wear work clothes home. Use a vacuum equipped with a HEPA filter to vacuum work clothes after they are worn. Launder them separately. Do not shake or use compressed air to remove dust from work clothes.

6. **Waste Disposal.** Dispose of discarded linings, used rags, cloths and HEPA filters with care, such as in sealed plastic bags. Consult applicable EPA, state and local regulations on waste disposal.

Regulatory Guidance

References to OSHA, NIOSH, MSHA, and EPA, which are regulatory agencies in the United States, are made to provide further guidance to employers and workers employed within the United States. Employers and workers employed outside of the United States should consult the regulations that apply to them for further guidance.

Notes

Section 1 Exploded View

Coverless Planetary Wheel-End

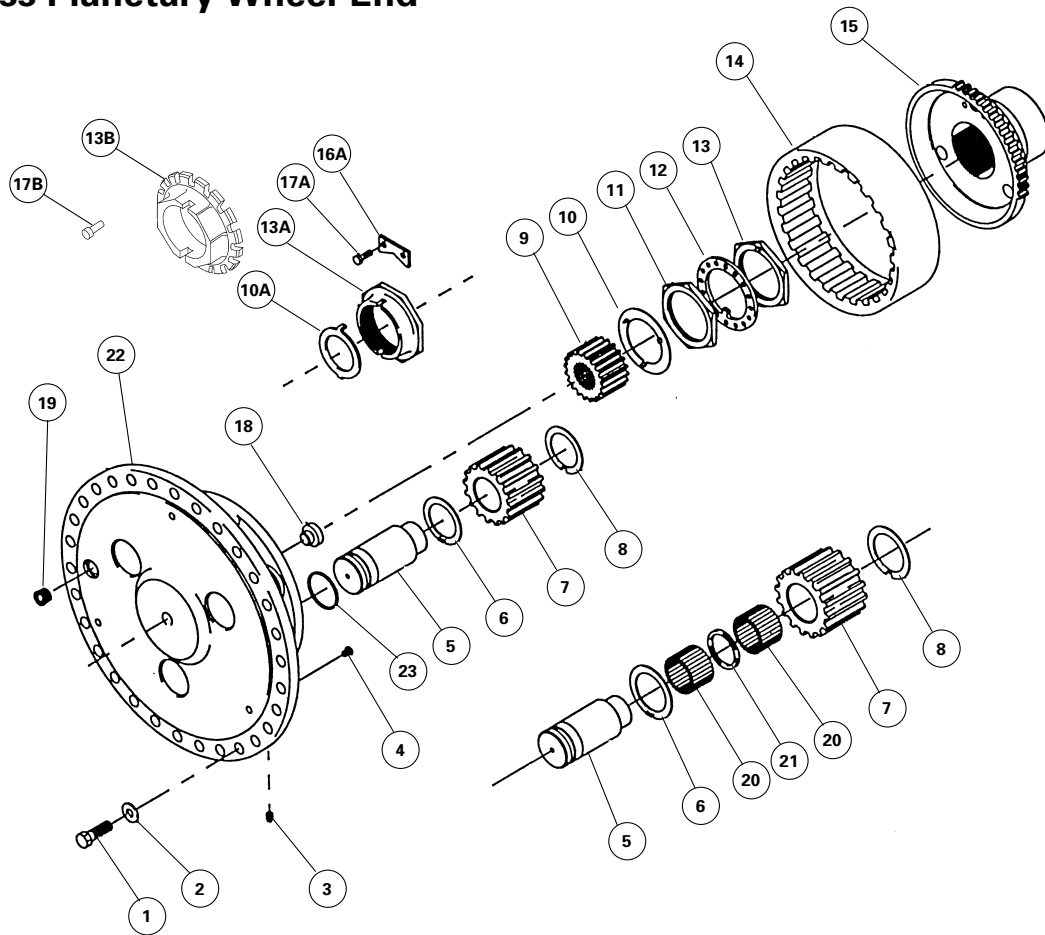

Item	Description	Item	Description
1	Planetary Spider to Hub Capscrew	13/13A	Wheel Bearing Adjusting Nut
2	Planetary Spider to Hub Washer	13B	Wheel Bearing Adjusting Nut
3	Shaft Planet Pinion Setscrew	14	Planetary Ring Gear
4	Ring Gear Thrust Button	15	Planetary Ring Gear Hub
5	Planet Pinion Shaft	16A	Hub Nut Lock
6	Planet Pinion Outer Thrust Washer	17A	Capscrew
7	Planetary Drive Pinion	17B	Capscrew
8	Planet Pinion Inner Thrust Washer	18	Axle Shaft Thrust Button
9	Planetary Sun Gear	19	Oil Drain Plug
10	Sun Gear Thrust Washer	20	Needle Roller Bearing
10A	Sun Gear Thrust Washer	21	Needle Roller Bearing Spacer
11	Wheel Bearing Adjusting Jam Nut	22	Spider
12	Wheel Bearing Adjusting Washer	23	O-Ring

Section 1 Exploded View

Drum Brake and Disc Brake Assemblies

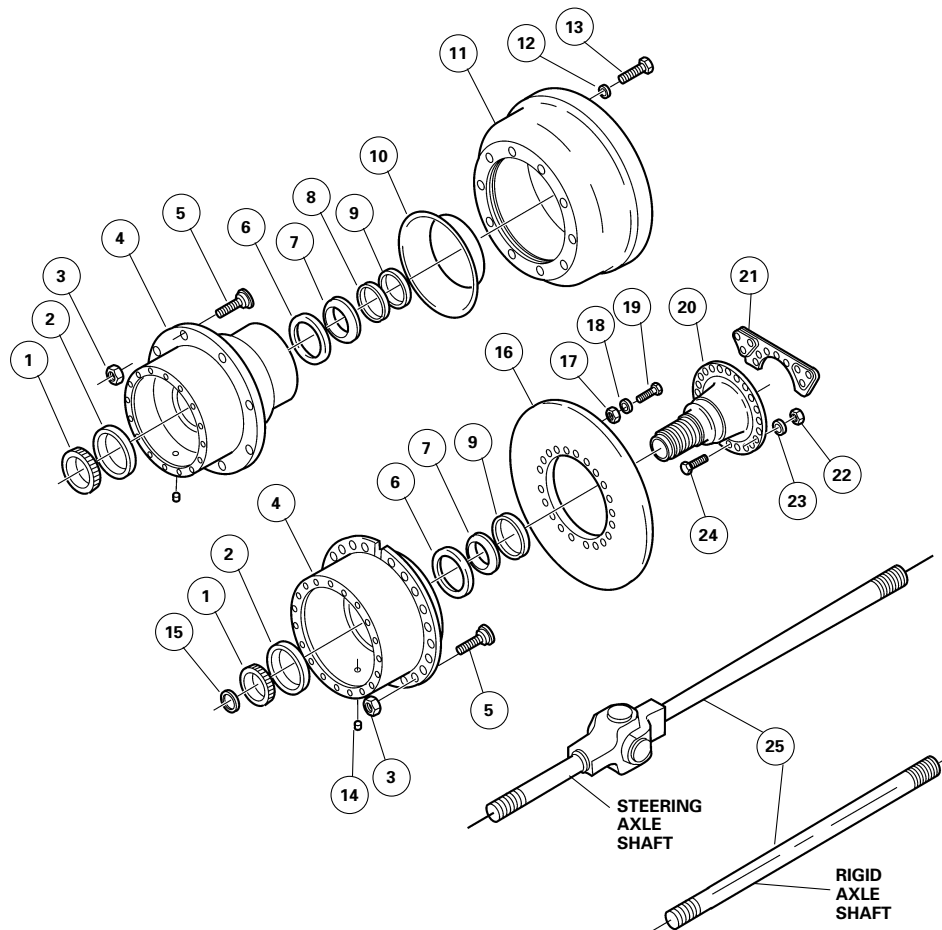

Item	Description	Item	Description
1	Outer Wheel Bearing Cone	14	Oil Drain Plug
2	Outer Wheel Bearing Cup	15	Axle Shaft Snap Ring
3	Wheel Stud Nut	16	Brake Disc
4	Wheel Hub	17	Disc Mounting Nut (If Applicable)
5	Wheel Stud	18	Disc Mounting Washer
6	Inner Wheel Bearing Cup	19	Disc Mounting Capscrew
7	Inner Wheel Bearing Cone	20	Spindle
8	Spacer	21	Caliper Mounting Adapter
9	Hub Inner Bearing Oil Seal	22	Spindle to Housing Nut (If Applicable)
10	Oil Slinger	23	Spindle to Housing Washer
11	Brake Drum	24	Spindle to Housing Capscrew
12	Drum Mounting Washer	25	Axle Shaft
13	Drum Mounting Capscrew		

Description

RICO coverless spider design planetary axles incorporate a single or double reduction carrier with hypoid gearing mounted in the axle center. Final gearing reduction occurs in the wheel hubs by planetary design spur gears.

RICO planetary axles permit the carrier hypoid gearing and axle shafts to carry only nominal torsional loads. At the same time, the planetary axles also provide the highest practical numerical gear reduction at the wheels.

- Power is transmitted by the hypoid gear set in the carrier to the axle shafts and the sun gear of the final reduction, through the revolving planetary gears and into the planetary spider which drives the wheel hub.
- The floating sun gear teeth mesh with teeth of the planetary spur gears.
- The planetary gears rotate on planetary shafts mounted on the spider. The planetary gear teeth, in turn, mesh with the fixed or floating ring gear teeth.

Axle Models Covered in This Manual

Rigid Axles

PRC 594	PRC 866	PRLC 755	PRLC 1736
PRC 671	PRC 867	PRLC 756	PRLC 1756
PRC 673	PRC 1314	PRLC 824	PRLC 1752
PRC 674	PRC 1756	PRLC 874	PRLC 1757
PRC 727	PRLC 616	PRLC 1735	PRLC 1794
			PRLS 614

Steering Axles

PSC 594	PSC 1044	PSC 1794
PSC 822	PSC 1485	PSTC 824
PSC 824	PSC 1614	
PSC 825	PSC 1615	
PSC 826	PSC 1617	

Tandem Axles

SPRC 673
SPRC 1356
SPRC 1735
SPRC 1756

Tridem Axles

EPRC 1356
EPRC 1735

Identification

To determine the exact axle model specification, refer to the identification tag located on the axle. **Figures 2.1, 2.2 and 2.3.**

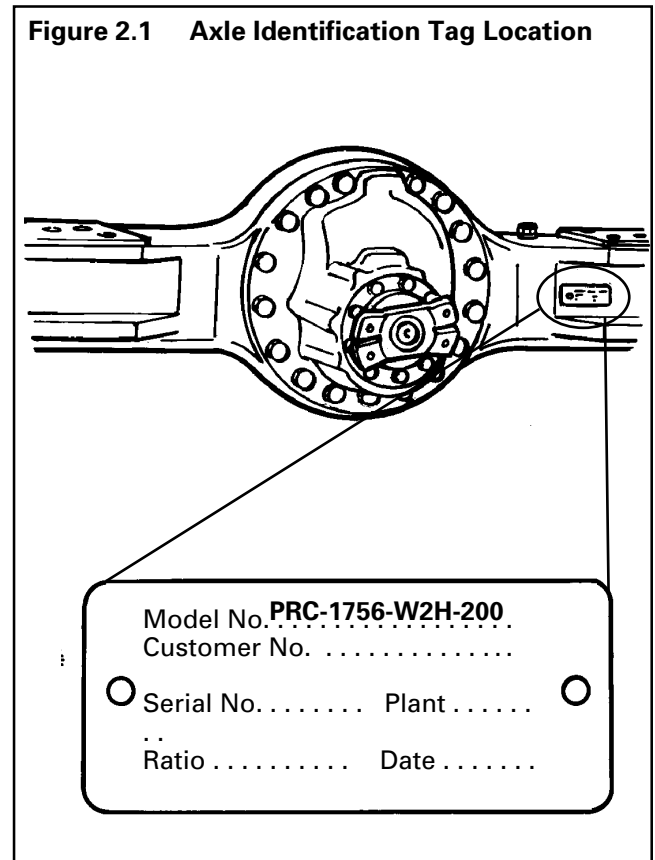

Section 2 Introduction

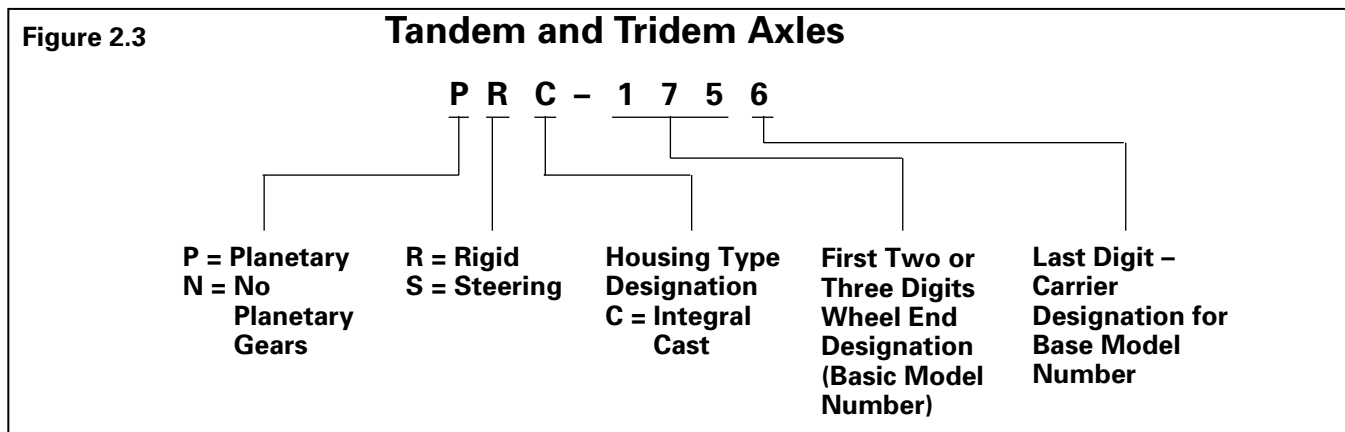
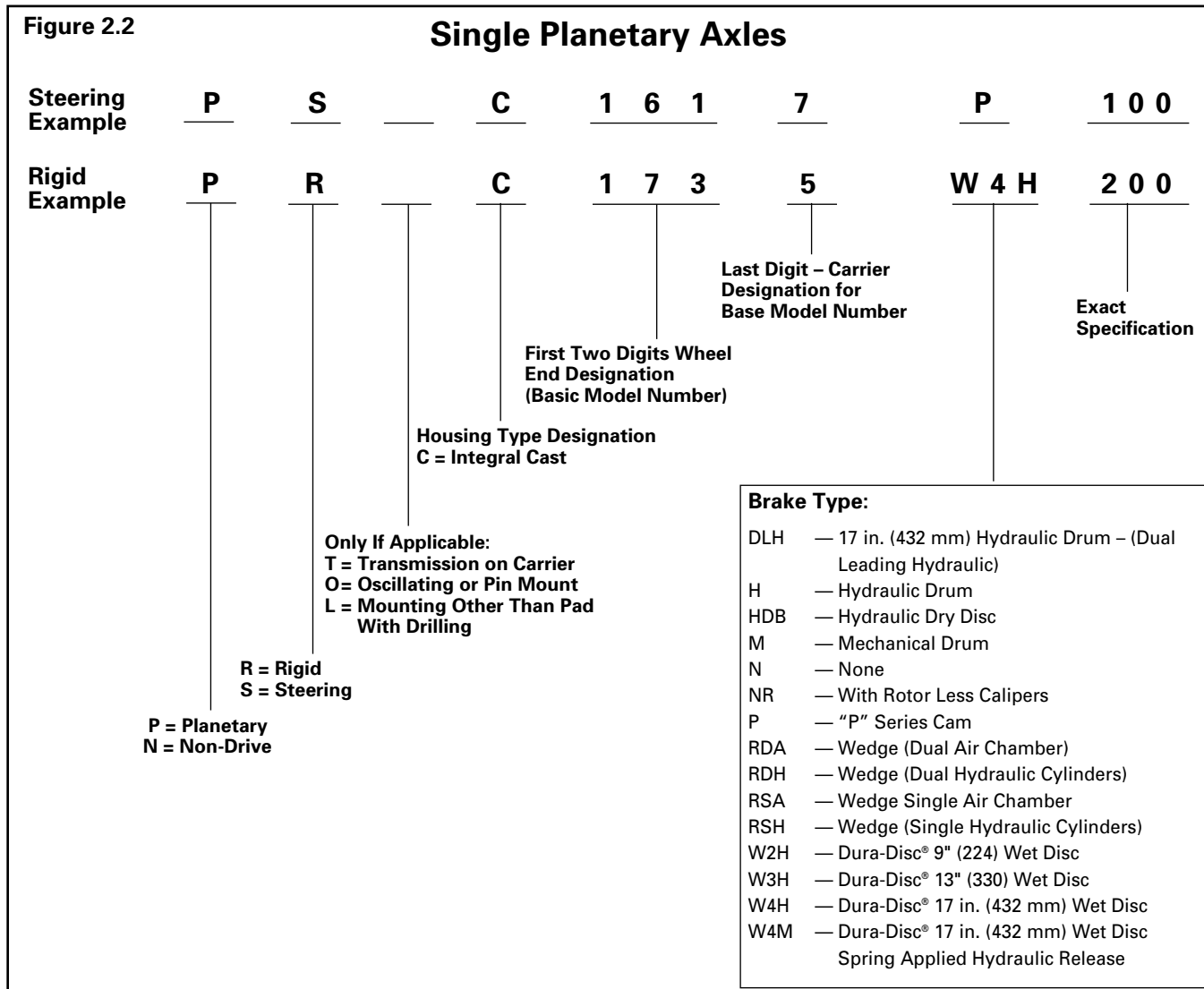

Remove and Disassemble the Planetary Wheel Ends

WARNING

To prevent serious eye injury, always wear safe eye protection when you perform vehicle maintenance or service.

1. Park the vehicle on a level surface.

WARNING

Block the wheels to prevent the vehicle from moving. Support the vehicle with safety stands. Do not work under a vehicle that is supported only by jacks. Jacks can slip or fall over and cause serious personal injury.

2. Block the wheels that will not be raised to prevent the vehicle from moving.
3. Raise the vehicle, so that the area you will service is off of the ground. Support the vehicle with safety stands. Refer to the vehicle manufacturer's maintenance manual for instructions on raising the vehicle.

Remove the Tires and Rims

Planetary axles can come equipped with dual demountable hubs or flange style hubs.

Figure 3.1. You can service the planetary gearing on flange style hubs without removing the tire from the wheel end.

1. **For axles with dual demountable hubs:** Refer to the vehicle manufacturer's removal instructions.
2. If the axle is equipped with an oil drain plug in the planetary spider, rotate the hub until the plug is at the bottom.
3. Remove the drain plug.
4. Drain and discard the lubricant.

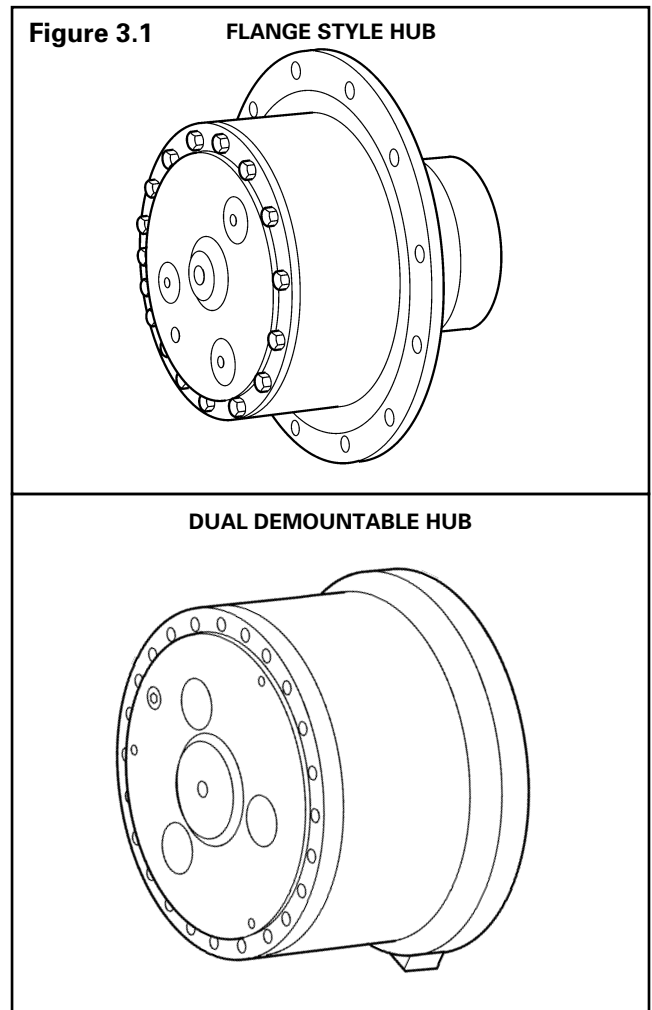

Section 3 Disassembly

Remove the Planetary Spider Assembly

1. Match mark the spider and wheel hub for correct alignment when you reassemble the unit. **Figure 3.2.**

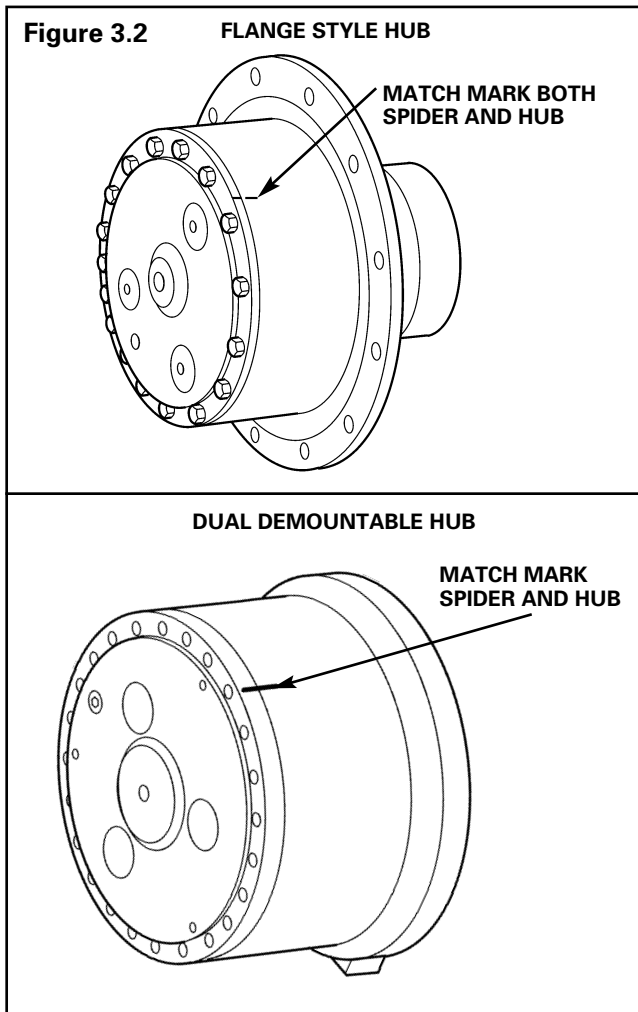

2. Insert a pry bar into the assembly notches and separate the planetary spider assembly from the wheel hub assembly. **Figure 3.3.** Do not remove the spider assembly at this time.
 - **For axles without assembly notches:** Hit the spider with a plastic or rubber mallet to separate the planetary assembly from the wheel hub assembly. Do not remove the spider assembly at this time.

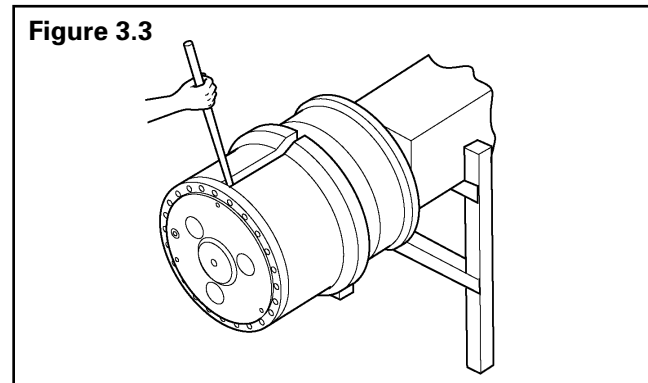

! WARNING

Take care when you use lifting devices. When you use a lifting strap, inspect the strap for damage before you use it. Do not use a lifting strap to shock load or drop load a component. Serious personal injury and damage to components can result.

4. Use a lifting device to remove the planetary spider assembly from the wheel hub assembly. **Figure 3.4.**

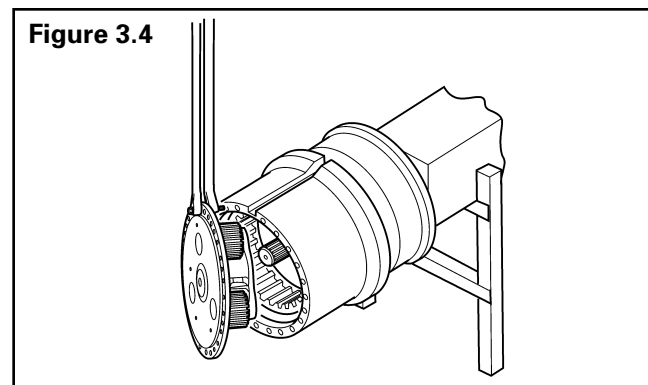

Disassemble the Planetary Spider Assembly

WARNING

Observe all **WARNINGS** and **CAUTIONS** provided by the press manufacturer concerning press operation to avoid serious personal injury and possible damage to components during assembly and installation procedures.

NOTE: During disassembly, mark or tag the planetary spider parts you do not plan to replace. Marking and tagging these parts, will aid correct installation during assembly.

1. Remove the setscrew from each pinion shaft.
2. Place the spider assembly in a press with the flange side DOWN.
 - **If a press is not available:** Use a brass drift and mallet to remove the pinion shafts.
3. Support the spider assembly as required.
4. Place a container of cushioning material under the press to catch the planetary pinion shafts as you press them out of the spider and planetary gears.
5. Press each pinion shaft out of the spider and planetary gear. **Figure 3.5 and Figure 3.6.**

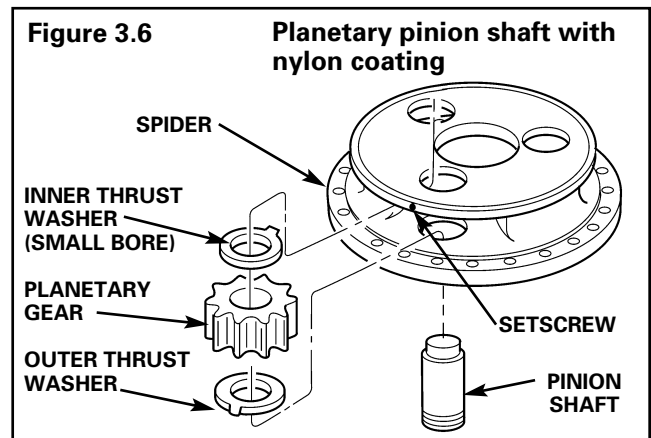
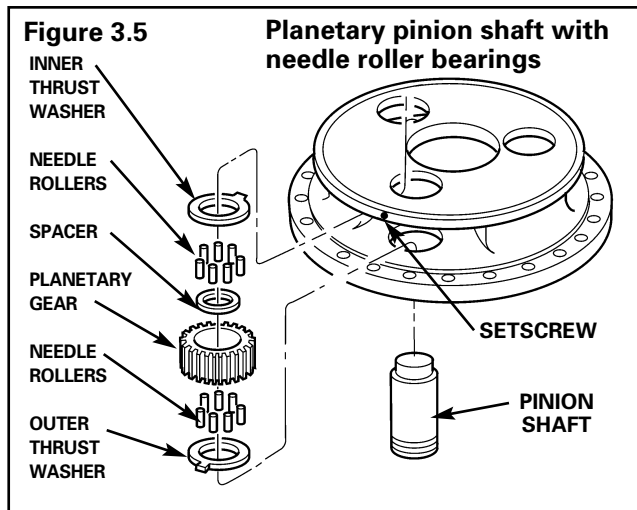

6. Remove the planetary gears and thrust washers from the planetary spider.
7. **For planetary pinion shafts with needle roller bearings:** Remove the needle roller bearings and spacer from the bore of the planetary gear.

Remove the Ring Gear and Axle Shaft

1. Remove the floating ring gear. If necessary, use a lifting device to remove the ring gear. **Figure 3.7.**
2. Remove the snap ring from the end of the axle shaft.
3. Remove the sun gear. **Figure 3.7.**

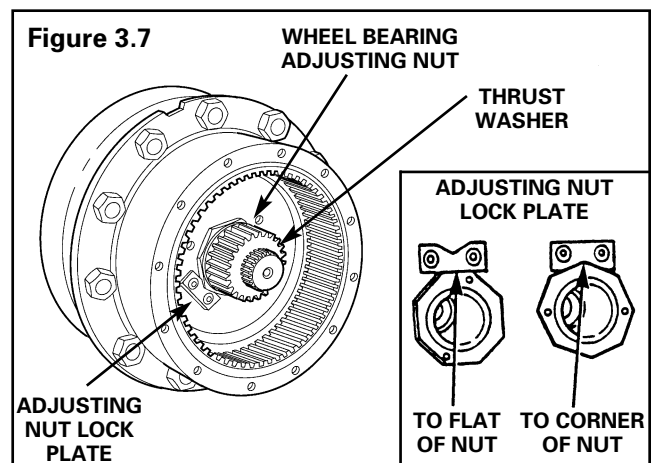

Section 3 Disassembly

4. Remove the sun gear thrust washer assembly. **Figure 3.8.**

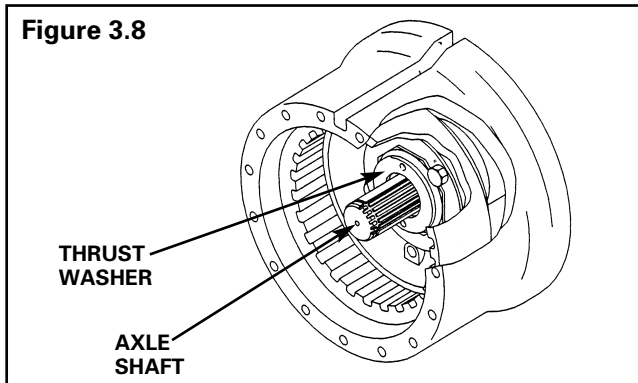

5. Remove the axle shaft.
 - **To remove the axle shaft from a steering axle:** Remove the wheel hub and spindle before you remove the axle shaft.

Prepare to Remove the Wheel Hub

Axles With Dry Disc Brakes

Remove the brake caliper and adapter assembly. Refer to Maintenance Manuals 4S, SCL 2 Series Dry Disc Brake Calipers and Maintenance Manual 4Y, SCL 35, 46, 53 Dry Disc Brake Calipers. To order these publications, call Meritor's Customer Service Center at 800-535-5560.

Axles With Wet Disc Brakes

Refer to Maintenance Manual 4L, Wet Disc Brakes, for instructions on removing and servicing the wheel hub, brake driver, hub oil seal, wheel bearings and spindle. To order this manual, call Meritor's Customer Service Center at 800-535-5560.

Axles With Hydraulic or Mechanical Brakes

For hydraulic or mechanical brake removal and service instructions refer to Maintenance Manual 4S, SCL 2 Series Dry Disc Brake Calipers and Maintenance Manual 4Y, SCL 35, 46 and 53 Dry Disc Brake Calipers. To order these manuals, call Meritor's Customer Service Center at 800-535-5560.

Axles With P Series or RSA Drum Brakes

! WARNING

When you work on a spring chamber, carefully follow the service instructions of the chamber manufacturer. Sudden release of a compressed spring can cause serious personal injury.

1. If the brake has spring chambers, manually compress and lock the springs to release the brakes.
2. Turn the slack adjuster manual adjusting nut until the brake shoes fully retract and the drum clears the lining. If RICO automatic slack adjusters are used, refer to RICO Maintenance Manual 4B, Automatic Slack Adjuster for the correct adjustment procedure. To order this publication, call Meritor's Customer Service Center at 800-535-5560.

Prepare to Remove the Ring Gear Hub and Wheel Hub

Wheel Bearings With Single Adjusting Nut and Lockplates

1. Remove the capscrews from the adjusting nut lock. The adjusting nut features one of the following designs.
 - A ring that secures all corners of the nut
 - One or two "bow ties" that secure one or two corners of the adjusting nut or the flat of the nut
2. Remove the wheel bearing adjusting nut lock and wheel bearing nut.

Wheel Bearings With Scalloped Flange Adjusting Nut

NOTE: To aid in capscrew removal, it may be necessary to use a torch to apply heat to the capscrew to loosen it. Follow the torch manufacturer's instructions.

1. Remove the locking capscrew located in the scallop of the nut. Check the capscrew for wear. Replace a worn or damaged capscrew.
2. Remove the wheel bearing nut.

Wheel Bearings With Double Adjusting Nuts

Remove the wheel bearing jam nut, washer and wheel bearing adjusting nut.

Remove the Ring Gear Hub and Wheel Hub

CAUTION

Support the wheel hub, as shown in Figure 3.10, before you remove the ring gear and the ring gear hub assembly. Do not remove the ring gear and the ring gear hub assembly without supporting the wheel hub. Serious personal injury and damage to components can result.

1. Remove the ring gear hub by pulling it straight out of the wheel hub and off of the spindle. To avoid dropping and possibly damaging the outer wheel bearing cone, ensure that the outer wheel bearing cone remains in place as you remove the ring gear hub. **Figure 3.9.**
 - **If you cannot remove the ring gear hub by hand:** Install capscrews into the puller screw holes in the ring gear hub flange. Tighten each capscrew the same amount to separate the ring gear hub assembly from the spindle and the wheel hub.

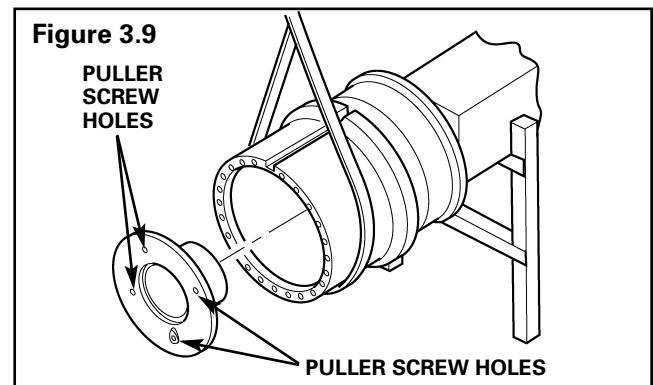

2. Remove the outer wheel bearing from the ring gear hub.

NOTE: Some ring gear hub assemblies include a hub and ring sleeve insert. You can not service these components separately.

3. Use a chain fall or similar device to lift the hub and drum slightly to relieve the hub weight and drum-to-brake shoe drag. **Figure 3.10 and Figure 3.11.**
4. Remove the assembly from the hub spindle.

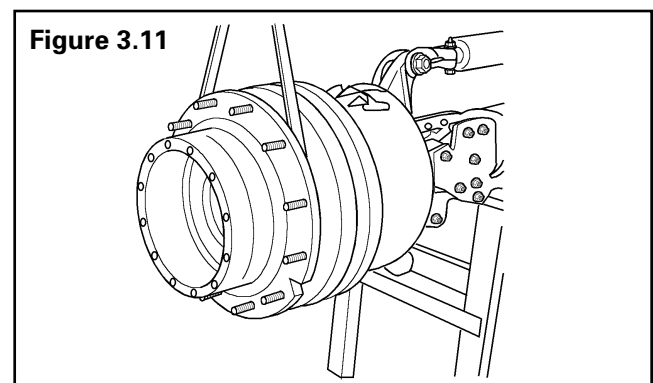
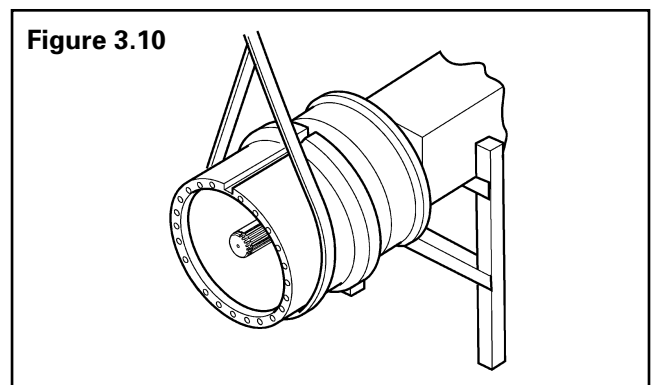

Section 3

Disassembly

Remove the Hub Oil Seal and Bearings

1. Position the wheel hub with the brake end UPWARD.
2. Some axle model designs with dry disc brakes provide enough clearance to remove the hub oil seal, bearing cone and bearing cups without removing the rotor.
 - **If you can remove the hub oil seal, bearing cone and bearing cups from the axle without removing the rotor:** Proceed to Step 4.
 - **If you must remove the rotor from the wheel hub to remove the hub oil seal, bearing cone and bearing cups:** Proceed to Step 3.
3. Remove the rotor mounting capscrews and washers. Remove the rotor.
4. Remove the hub oil seal with a suitable puller. Do not scratch the hub seal bore surface.
5. Remove the inner bearing cone.
6. Remove the bearing cups with a suitable puller.

Remove the Brake Drum or Disc Brake Rotor

1. Match mark the drum and hub.
2. Remove the capscrews and washers from the brake drum or rotor joint.

WARNING

Take care when you use lifting devices. When you use a lifting strap, inspect the strap for damage before you use it. Do not use a lifting strap to shock load or drop load a component. Serious personal injury and damage to components can result.

3. Remove the brake drum or rotor from the wheel hub. If necessary, use a lifting device to remove the brake drum or rotor.

Remove the Brake Shoes

To remove the brake shoes, refer to the correct maintenance manual.

- **For P series brakes:** Refer to Maintenance Manual 4, Cam Brakes.
- **For RSA drum brakes:** Refer to Maintenance Manual 4P, Off-Highway Heavy-Duty Brakes.
- **For SCL 2 series dry disc brakes:** Refer to Maintenance Manual 4S, SCL 2 Series Dry Disc Brake Calipers.
- **For SCL 35, 46 or 53 series dry disc brakes:** Refer to Maintenance Manual 4Y, SCL 35, 46, 53 Dry Disc Brake Calipers.

To order these publications, call Meritor's Customer Service Center at 800-535-5560.

Remove the Spindle

Axles With Dry Disc Brakes

1. Match mark the spindle and housing flange.
2. Use straps and a lifting device to support the spindle.
3. Remove the spindle mounting capscrews and washers.
4. Remove the spindle from the axle housing or steer knuckle.

Steering Axles With RSA Drum Brakes

1. Remove all air from the air system.
2. Remove the air lines from the air chamber. Tag the lines and ports to aid reassembly.

WARNING

When you work on a spring chamber, carefully follow the service instructions of the chamber manufacturer. Sudden release of a compressed spring can cause serious personal injury.

3. If the brake has spring chambers, manually compress and lock the springs to release the brakes.

Section 3 Disassembly

4. Match mark the air chamber housing tube and the brake spider plunger housing to aid reassembly.
5. Remove the set-screw that retains the air chamber assembly in the spider plunger housing.
6. **If there is a collet nut on the threads of the chamber housing tube:** Use a hammer and a brass drift to loosen the collet nut.
7. Remove the air chamber assembly from the plunger housing. If necessary, use a strap wrench to remove the air chamber assembly.
8. Remove the brake shoe return springs.
9. Rotate the brake shoes to allow access to the spindle/brake spider mounting capscrews.
10. Match mark the brake spider and steering knuckle to aid correct installation at assembly.
11. Remove the two capscrews and washers that mount the brake spider and spindle to the steering knuckle at the 11 and 1 o'clock positions.
12. To aid spindle removal, install two 4- 6-inch (10.16-15.24 cm) long studs with 0.875-14 UNF threads on the end that engage the steering knuckle.
13. Support the spindle and brake spider assembly.
14. Remove the remaining capscrews and washers.
15. Remove the brake spider and brake shoe assembly.



CAUTION

Avoid damaging the oil seal in the spindle when you remove the spindle. Lubricant loss and damage to components can result.

16. Carefully remove the spindle from the steering knuckle by sliding the spindle over the outer end of the axle shaft and universal joint.
17. Remove the axle shaft and universal joint assembly.

Steering Axles With RSH Drum Brakes

1. Remove the hydraulic lines from the hydraulic chamber. Tag the lines to aid reassembly.
2. Match mark the hydraulic chamber housing tube and the brake spider plunger housing to aid reassembly.
3. Remove the set screw that retains the fluid within the spider plunger housing.
4. **If there is a collet nut on the threads of the chamber housing tube:** Use a hammer and a brass drift to loosen the collet nut.
5. Remove the hydraulic chamber assembly from the plunger housing. If necessary, use a strap wrench to remove the hydraulic chamber assembly.
6. Remove the brake shoe return springs.
7. Rotate the brake shoes to allow access to the spindle/brake spider mounting screws.
8. Match mark the brake spider and steering knuckle to aid reassembly.
9. Remove the two capscrews and washers that mount the brake spider and spindle to the steering knuckle at the 11- and 1-o'clock positions.
10. To aid spindle removal, install two 4- 6-inch (10.16-15.24 cm) long studs with 0.875-14 UNF threads on the end that engage the steering knuckle.
11. Support the spindle and brake spider assembly.
12. Remove the remaining capscrews and washers.
13. Remove the brake spider and brake shoe assembly.



CAUTION

Avoid damaging the oil seal in the spindle when you remove the spindle. Lubricant loss and damage to components can result.

14. Carefully remove the spindle from the steering knuckle by sliding the spindle over the outer end of the axle shaft and universal joint.
15. Remove the axle shaft and universal joint assembly.

Section 3

Disassembly

Steering Axles With P Series Cam Brakes

1. Remove the brake shoe return springs.
2. Rotate the brake shoes until enough clearance exists to remove the spindle mounting nuts and washers with a wrench.
3. Remove the spindle mounting nuts and washers.

CAUTION

Avoid damaging the oil seal in the spindle when you remove the spindle. Lubricant loss and damage to components can result.

4. Carefully remove the spindle from the steering knuckle by sliding the spindle over the outer end of the axle shaft assembly.
5. Remove the axle shaft and universal joint assembly.

Rigid Axles With P Series Cam Brakes

Some rigid axles feature a two-piece camshaft and coupling which allows you to remove the camshaft without removing the slack adjuster. When servicing an axle with a two-piece camshaft and coupling, proceed to Step 6.

1. Remove the brake shoe return springs.
2. Rotate the brake shoes to allow access to the brake camshaft and the spindle mounting capscrews.
3. Remove the slack adjuster clevis pin that connects the air chamber push rod.
4. Remove the snap ring and washers that connect the slack adjuster to the brake camshaft. Stack the washers and separate them from other parts.
5. Remove the slack adjuster and washers. Separate the washers from other parts and prevent them from mixing with the washers you previously removed.
6. Remove the snap rings that retain the camshaft in the spindle support boss.

7. Remove the brake camshaft from the spindle. Separate the washers you removed from the face of the spindle boss. Prevent the washers from mixing with the washers you previously removed.

WARNING

Take care when you use lifting devices. When you use a lifting strap, inspect the strap for damage before you use it. Do not use a lifting strap to shock load or drop load a component. Serious personal injury and damage to components can result.

8. Use straps and a lifting device to support the spindle and brake shoe assembly.
9. Match mark the housing and spindle flange.
10. Remove the mounting capscrews and washers.
11. Remove the spindle from the axle housing.

Clean Ground or Polished Parts

WARNING

To prevent serious eye injury, always wear safe eye protection when you perform vehicle maintenance or service.

Solvent cleaners can be flammable, poisonous and cause burns. Examples of solvent cleaners are carbon tetrachloride, emulsion-type cleaners and petroleum-based cleaners. To avoid serious personal injury when you use solvent cleaners, you must carefully follow the manufacturer's product instructions and these procedures:

- Wear safe eye protection.
- Wear clothing that protects your skin.
- Work in a well-ventilated area.
- Do not use gasoline or solvents that contain gasoline. Gasoline can explode.
- You must use hot solution tanks or alkaline solutions correctly. Follow the manufacturer's instructions carefully.
- Use a cleaning solvent to clean ground or polished parts or surfaces. Kerosene or diesel fuel oil can be used for this purpose. NEVER USE GASOLINE.
- Remove gasket material from parts. Be careful not to damage ground surfaces.
- DO NOT clean ground or polished parts in a hot solution tank, water, steam or alkaline solution.

Clean Parts With Rough Finishes

- Parts with a rough finish can be cleaned with cleaning solvent or in a hot solution tank with a weak alkaline solution.
- Parts must remain in hot solution tanks until completely cleaned and heated.
- Parts must be washed with water until the alkaline solution is removed.

Clean Axle Assemblies

- A complete axle assembly can be steam cleaned on the outside to remove dirt.
- Before the axle is steam cleaned, close or put a cover over all openings in the axle assembly. Examples of openings are breathers or vents in air chambers.

Dry Cleaned Parts

- Dry the parts immediately after cleaning and washing.
- Dry the parts with soft clean paper or rags.

CAUTION

Damage to bearings can be caused if dried by rotating with compressed air.

- Except for bearings, parts can be dried with compressed air.

Prevent Corrosion

- Apply a light lubricant to cleaned and dried parts that are not damaged and are to be assembled.
- Apply a special material that prevents corrosion to all surfaces. If parts are to be stored, wrap the parts in special paper that prevents corrosion.

Inspect Parts

It is very important to inspect all parts carefully and completely before the axle or carrier is assembled. Check all parts for wear and replace damaged parts. Replacement of damaged or worn parts will prevent breakdown of assembly later.

Section 4

Prepare Parts for Assembly

Inspect Tapered Roller Bearings

Inspect the cup, cone, rollers and cage of all tapered roller bearings in the assembly. If any of the following conditions exist, the bearing must be replaced:

- The center of the large diameter end of the rollers are worn level with, or below the surface.
- The center of the large diameter end of the rollers are worn to a sharp edge. **Figure 4.1.**

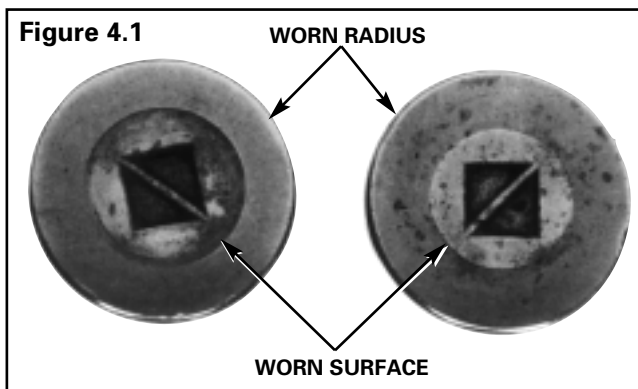

- A visible roller groove in the cup or cone inner race surfaces. The groove can be seen at the small or large diameter end of both parts. **Figure 4.2.**

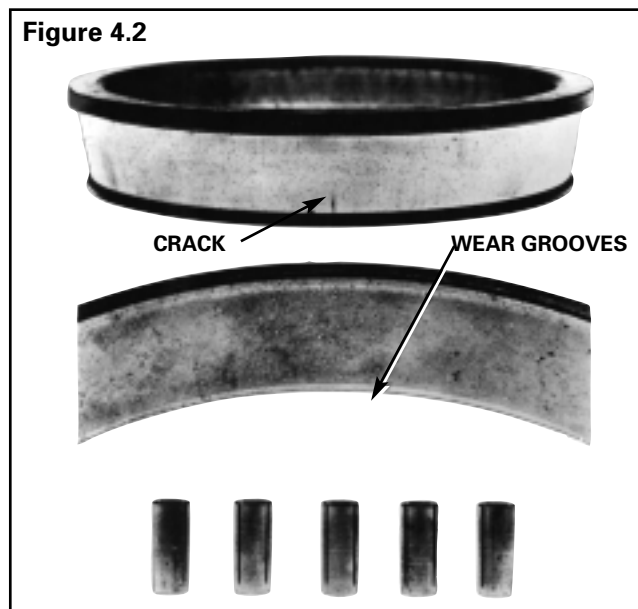

- Deep cracks or breaks in the cup, cone inner race or roller surfaces.
- Bright wear marks on the outer surface of the roller cage. **Figure 4.3.**

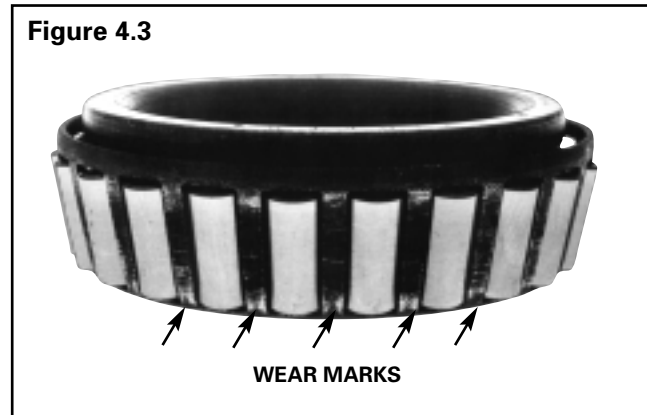

- Damage on rollers and on surfaces of the cup and cone inner race that touch the rollers. **Figure 4.4.**

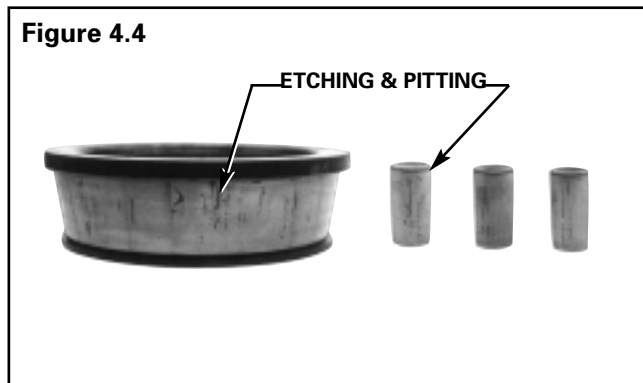

Section 4

Prepare Parts for Assembly

- Damage on the cup and cone inner race surfaces that touch the rollers. **Figure 4.5.**

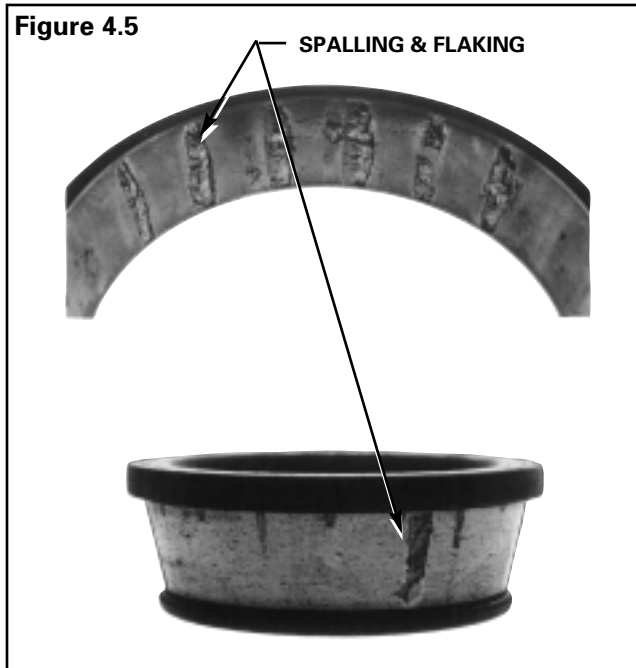

Inspect Planetary Wheel End Components

Inspect the planetary reduction, planetary gears, sun gear and ring gear assembly for wear or damage. Replace gears, shafts or thrust washers that are scored, pitted, ridged, chipped or worn.

Repair or Replace Parts

Replace worn or damaged parts of an axle assembly. The following are some examples to check for repair and possible replacement:

- Replace any fastener if corners of the head are worn.
- Replace washers if damaged.
- Replace gaskets, oil seals or grease seals at the time of axle repair.
- Clean parts and apply new liquid gasket material where required when axle is assembled.

- Remove nicks, marks and burrs from parts having machined or ground surfaces. Use a fine file, India stone, emery cloth or crocus cloth for this purpose.
- Clean and repair threads of fasteners and holes. Use a die or tap of the correct size or a fine file for this purpose.

! CAUTION

Threads must be without damage and clean so that accurate adjustment and correct torque values can be applied to fasteners and parts.

- Tighten all fasteners to correct torque values.

! WARNING

Do not repair axle housings by bending or straightening. Repair of axle housings by bending or straightening can cause poor performance and possible unsafe operation of the axle. This can cause serious personal injury.

Repair Welding

Do not repair weld drive axle assemblies. Repair welding can detract from the structural integrity of a component, particularly to heat treated parts where the benefit of heat treatment can be nullified by welding.

Remove Capscrews Fastened With Liquid Adhesive

! CAUTION

Do not use impact wrenches or strike components with a hammer.

To remove capscrews fastened with liquid adhesive, use the regular mechanical disassembly procedure.

If the removal of a capscrew, for example, becomes difficult due to a worn head or unusually high breakaway torque, the locking strength can be reduced by heating the threaded area to approximately 300°F (150°C). Heat slowly to avoid thermal stresses in components.

Section 4

Prepare Parts for Assembly

®

Cleaning

WARNING

To avoid serious personal injury, trichloroethylene must not come in contact with your skin. Do not smoke and avoid breathing vapors in closed rooms without ventilation. Do not use trichloroethylene near flames, welding operations or hot surfaces exceeding 900°F (482°C).

Clean the capscrew, nut or bolt tapped hole and fastener thread carefully. Use a cleaning solvent such as trichloroethylene or equivalent to remove dirt, oil, grease or moisture.

Using Dri-Loc Fasteners and RICO Liquid Adhesive

NOTE: Do not apply RICO liquid adhesive or any other type of fastener retainer material, sealant or adhesive on Dri-Loc fasteners or in the threaded holes.

NOTE: No cure time is required for Dri-Loc fasteners before rebuilding the axle and returning it to service.

1. Wipe excess oil residue from the threaded holes of all components that use Dri-Loc fasteners.
2. Assemble the components that use Dri-Loc fasteners.
3. Tighten the Dri-Loc fasteners to the specified torque value.

Reusing Dri-Loc Fasteners and Loctite® No. 277

WARNING

Take care when you use Loctite® to avoid serious personal injury. Follow the manufacturer's instructions to prevent irritation to the eyes and skin.

1. Wipe excess oil residue from the Dri-Loc fasteners and threaded holes.

NOTE: Do not apply liquid adhesive to the fastener. Trapped air in the threaded hole will create back pressure and “blow out” the adhesive as the fastener advances.

2. Apply Loctite® No. 277 adhesive to the threaded holes only. Before threading in the fasteners, visually check to make sure that the adhesive contacts the threads. **Figure 4.6.**

Figure 4.6

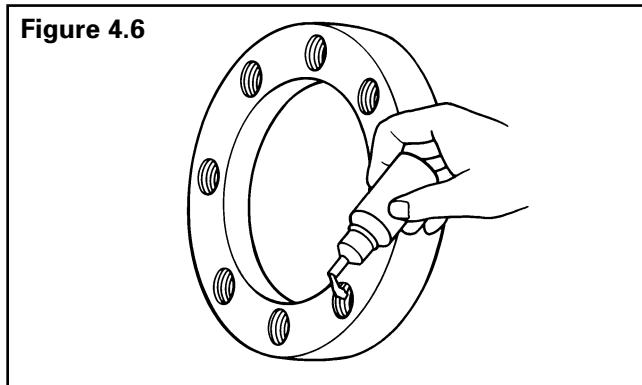

3. Tighten the fasteners to the specific torque value recommended for the fastener. Loctite® No. 277 will not alter the torque requirement.

NOTE: No cure time is required for Loctite® No. 277 before rebuilding the axle and returning it to service.

4. **When servicing drive units assembled with Dri-Loc fasteners or with Loctite® No. 277 in threaded holes where the fasteners do not require removal:** Check each fastener for tightness by tightening the fastener to the minimum specified torque.
 - If the fastener does not rotate, the fastener is tightened to the correct torque.
 - If the fastener rotates to any degree, remove it from the component and apply liquid adhesive to the threaded hole.

Section 4

Prepare Parts for Assembly

Applying Silicone Gasket Material

RICO recommends the following liquid gasket materials:

- ThreeBond 1216
- Loctite® 5699

! WARNING

Take care when you use silicone gasket materials to avoid serious personal injury. Follow the manufacturer's instructions to prevent irritation to the eyes and skin.

! CAUTION

The amount of liquid gasket material applied must not exceed a 0.125 in. (3.18 mm) diameter bead. Too much gasket material can block lubrication passages and result in damage to components.

1. Remove all old gasket material from both surfaces.
2. Clean the surfaces where liquid gasket material will be applied. Remove all oil, grease, dirt and moisture.
3. Thoroughly dry both surfaces.
4. Apply approximately a 0.125 inch (3.18 mm) diameter continuous bead of liquid gasket material around one surface.

Also apply gasket material around the edge of all fastener holes on that surface. **Figure 4.7.**

5. Assemble the components quickly to permit the gasket material to compress evenly between parts.
6. Tighten the fasteners with the required torque.

Flush Lube From the Axle

The rigid axle wheel end and housing bowl share the same oil. Lubricant contamination of the wheel end or housing bowl can spread to all areas of the axle.

1. If the housing bowl has magnets, remove all metallic debris from the magnets.
2. Flush lubricant from the entire axle, including the wheel ends and housing bowl, before you assemble the axle.

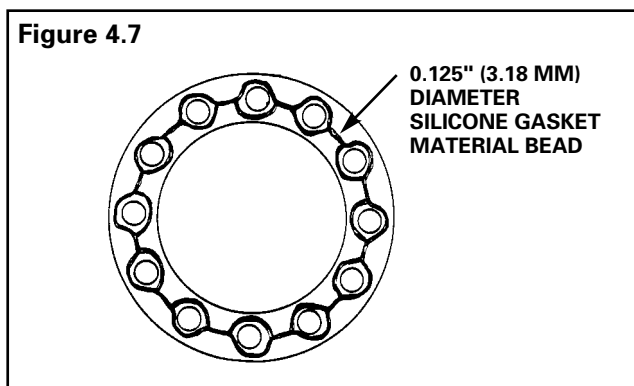

Notes

Install the Spindle

Install the Spindle on Rigid Axles With P Series Cam Brakes

WARNING

To prevent serious eye injury, always wear safe eye protection when you perform vehicle maintenance or service.

1. Install two 4-inch (10.14 cm) long temporary studs into the axle housing flange at the 1- and 11- o'clock positions. **Figure 5.1.**

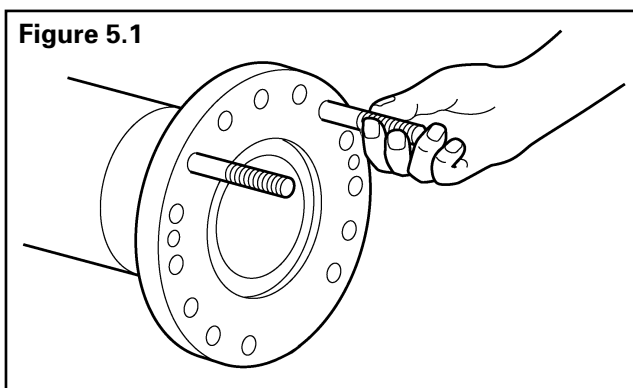

2. Apply a 0.125-inch (3.18 mm) diameter continuous bead of liquid gasket material around the flange mounting face of the axle housing.

WARNING

Take care when you use lifting devices. When you use a lifting strap, inspect the strap for damage before you use it. Do not use a lifting strap to shock load or drop load a component. Serious personal injury and damage to components can result.

3. Align the spindle and axle housing match marks. Install the spindle on the axle housing. If necessary, use an overhead crane to lift and support large spindles. **Figure 5.2.**

Figure 5.2

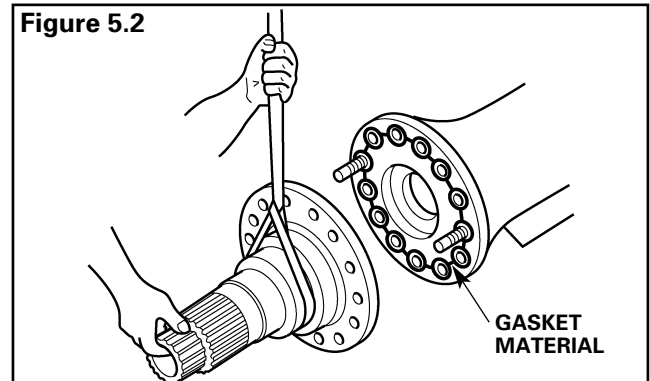

4. Install and hand tighten the spindle mounting capscrews and washers. Remove the temporary studs and replace them with capscrews and washers.
5. Tighten the capscrews according to the torque specifications shown in **Table A.** 

Table A: Spindle Mounting Capscrew Torque Specifications

Size	Torque	
	lb-ft	N•m
1/2"-12	85-115	115-156
9/16"-18	130-165	176-224
5/8"-11, - 18	210-230	284-311
3/4"-10	310-400	420-542
7/8"-9, - 14	575-650	779-880
1"-12, - 14	850-1100	1152-1491

6. Replace the brake camshaft bushings and grease seals in the spindle boss and camshaft brackets. Refer to Maintenance Manual 4, Cam Brakes. To order this publication, call Meritor's Customer Service Center at 800-535-5560.
7. Install the cam head thrust washer onto the camshaft. Apply O-617-A or -B chassis grease to the camshaft bushings and journals.
8. Install the camshaft through the spindle bushings. Install the washers and slide the camshaft through the air chamber support bracket.
 - **For two-piece camshaft designs:** Engage the coupling when you install the camshafts.

Section 5 Assembly

- Install the slack adjuster, washers, and snap ring. Connect the slack adjuster to the air chamber push rod yoke. Check that the snap ring is installed to the camshaft at the inner face of the spindle boss.

Install the Spindle on Rigid Axles With Dry Disc Brakes

- For axle models that use capscrews to mount the spindle:** Install two 4-inch (10.14 cm) long temporary studs into the axle housing flange at the 1-and 11-o'clock positions. **Figure 5.1.**
- For axle models that use a "bow-tie" caliper configuration:** Use one bolt to guide the spindle onto the axle.
- Apply a 0.125-inch (3.18 mm) diameter continuous bead of liquid gasket material around the flange mounting face of the axle housing.
- Align the spindle with the axle housing match marks to correctly position the brake caliper mounting bosses. Install the spindle on the axle housing.
- Install and hand tighten the spindle mounting capscrews and washers. Remove the temporary studs and replace them with capscrews and washers.
 - For models with studs in the axle housing:** Install washers and locknuts.
- Tighten the capscrews or locknuts according to the torque specifications shown in **Table B.** 

Table B: Spindle Mounting Capscrew and Locknut Torque Specifications

Size	Torque	
	lb-ft	N·m
1/2"-12	85-115	115-156
9/16"-18	130-165	176-224
5/8"-11, - 18	210-230	284-311
3/4"-10	310-400	420-542
7/8"-9, - 14	575-650	779-880
1"-12, - 14	850-1100	1152-1491

Install the Spindle on Steering Axles With P Series Cam Brakes

- Install the differential carrier assembly and the steering knuckles on the steering axles.
- Apply a thin coat of NLGI grade 1 or 2 grease to the following areas:
 - Oil seal lips and bushing bore in the end of the axle housing
 - Axle shaft assembly seal and bushing journals

CAUTION

Avoid damaging the housing oil seal when you install the shaft assembly. Lubricant loss and damage to components can result.

- Carefully install the axle shaft assembly through the steering knuckle and axle housing until the shaft engages the differential assembly side gear. **Figure 5.3.**
- If the original shaft support bushing in the bore of the spindle is worn or damaged:** Remove the oil seal and bushing and install a new bushing.

Figure 5.3

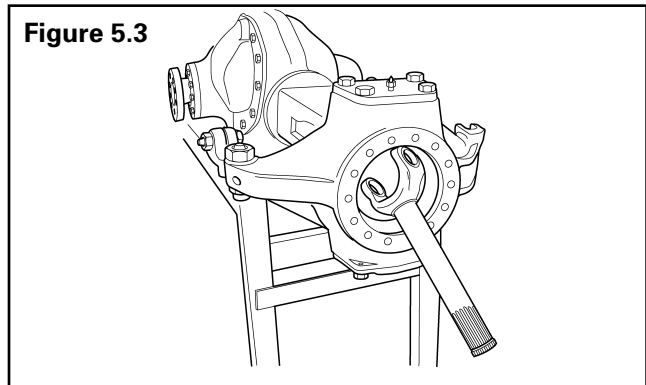

- Install a new oil seal in the spindle bore. Apply a thin coat of NLGI grade 1 or 2 grease to the seal lips and bushing bore.

CAUTION

Avoid damaging the oil seal in the spindle when you install the spindle. Lubricant loss and damage to components can result.

6. Carefully install the spindle on the steering knuckle by carefully sliding it over the outer end of the axle shaft assembly.
7. Install the spindle mounting washers and nuts. Hand tighten the nuts.
8. Tighten the 3/4-inch-19 nuts or capscrews to 310-400 lb-ft (420-542 N•m). 
9. **If you removed the brake shoes or camshaft:** Install the brake shoes or camshaft. Refer to Maintenance Manual 4, Cam Brakes. To order this publication, call Meritor's Customer Service Center at 800-535-5560.

Install the Spindle on Steering Axles With RSA Drum Brakes

1. Install the differential carrier assembly and the steering knuckles on the steering axle.
2. Apply a thin coat of NLGI grade 1 or 2 grease to the following areas:
 - Oil seal lips and bushing bore in the end of the axle housing
 - Axle shaft assembly seal and bushing journals

CAUTION

Avoid damaging the housing oil seal when you install the axle shaft assembly. Lubricant loss and damage to components can result.

3. Carefully install the axle shaft assembly through the steering knuckle and axle housing until the shaft engages the differential assembly side gear.
4. **If the original shaft support bushing in the bore of the spindle is worn or damaged:** Remove the oil seal and bushing and install a new bushing.
5. Install a new oil seal in the spindle bore. Apply a thin coat of NLGI grade 1 or 2 grease to the seal lips and bushing bore.

CAUTION

Avoid damaging the oil seal in the spindle when you install the spindle. Lubricant loss and damage to components can result.

6. Use a lifting device to install the spindle onto the steering knuckle. Carefully slide the spindle over the outer end of the axle shaft assembly and engage the two temporary guide studs.
7. Align the brake spider and brake shoe assembly with the spindle match marks. Install the brake spider and brake shoe assembly on the spindle. Refer to Maintenance Manual 4P, Off-Highway Heavy-Duty Brakes.
8. Install the spindle and brake spider mounting capscrews and washers. Remove the two temporary studs you installed during disassembly. Replace the temporary studs with capscrews and washers.
9. Tighten the capscrews according to the torque specifications shown in **Table C**. 

Table C: Spindle Mounting Capscrew and Locknut Torque Specifications

Size	Torque	
	lb-ft	N•m
1/2"-12	85-115	115-156
9/16"-18	130-165	176-224
5/8"-11, - 18	210-230	284-311
3/4"-10	310-400	420-542
7/8"-9, - 14	575-650	779-880
1"-12, - 14	850-1100	1152-1491

10. Install the air chamber assembly into the brake spider. Refer to Maintenance Manual 4P, Off-Highway Heavy-Duty Brakes.
11. Install the brake shoe return spring.
12. Connect the air lines to the correct ports in the air chamber assembly. Release the spring chamber after you adjust the wheel hub.

Section 5 Assembly

Install the Axle Shaft in Rigid Axle Models

Install the axle shaft through the spindle bore and housing until it engages the differential side gear. The shaft end with the snap ring groove must extend beyond the outer end of the spindle.

Assemble the Ring Gear Hub Assembly

NOTE: Install the ring gear immediately before you assemble the planetary spider.

1. Install the outer wheel bearing cone on the ring gear hub journal squarely against the hub shoulder.
2. Apply the same lubricant used in the wheel ends to the rollers.
3. Slip fit the bearing cone over the ring gear hub journal. Do not install the ring gear hub assembly on the spindle at this time.

Assemble the Hub, Bearings, Oil Seal and Drum or Rotor

1. If the hub bearing cups need to be replaced, install the new cups with a suitable driver.

NOTE: Most models require installation of the inner bearing cone prior to installation of the wheel hub oil seal into the bore of the wheel hub.

2. Apply lubricant to the inner bearing cone rollers. Install the bearing cone into the wheel hub.
3. If used, install the oil seal guard washer.
4. Position the new wheel hub oil seal so that the spring lip of the seal faces the wheel bearing. Use a suitable seal driver to drive the seal into the same location as the original wheel hub oil seal. Refer to the following list for three possible seal installation locations:
 - Bottom of the hub bore
 - Pushed-in until it contacts the guard washer
 - Flush with the end face of the hub

CAUTION

Use extreme care to avoid nicking the oil seal wear sleeve end when you install the oil seal wear sleeve. A nicked oil seal wear sleeve end can damage the seal lip when you install the wheel hub. Lubricant loss and damage to components can result.

5. If a sleeve is used, carefully install a new oil seal wear sleeve on the spindle.
6. Lubricate the seals in the following areas only.
 - **Conventional seals:** Lubricate the oil seal lips.
 - **Unitized seals:** Lubricate the inside diameter of the seal.
 - **Face seals:** Lubricate the contact surfaces of the metal rings. Do not apply lubricant to any other part of the face seal.
7. Apply a thin coat of lubricant to the oil seal journal surface of the spindle.
8. Install the brake rotor or drum and oil slinger.
 - **If the slinger fits loosely between the hub and drum:** Apply a bead of liquid gasket material to prevent rattling.
9. Install the drum or rotor mounting capscrews and washers.
 - **For dual tire models:** Align the air valve stem clearance notch in the drum outside diameter with the wheel hub notch.
10. Tighten the capscrews according to the torque specifications shown in **Table D.** 

Table D: Brake Rotor Mounting Capscrew Torque Specifications

Size	Torque	
	lb-ft	N·m
1/2"-12	85-115	115-156
9/16"-18	130-165	176-224
5/8"-11, - 18	210-230	284-311
3/4"-10	310-400	420-542
7/8"-9, - 14	575-650	779-880
1"-12, - 14	850-1100	1152-1491

Install the Wheel Hub

WARNING

Take care when you use lifting devices. When you use a lifting strap, inspect the strap for damage before you use it. Do not use a lifting strap to shock load or drop load a component. Serious personal injury and damage to components can result.

1. Use a lifting device to carefully lift and slide the wheel hub assembly over the spindle. Keep the wheel hub assembly aligned with the spindle to avoid oil seal damage. **Figure 5.5 and Figure 5.6.**
 - **For axle models with three threaded holes (5/8 inch-11 UNC) in the boss area near the outer wheel bearing:** You can temporarily attach the planetary ring gear hub assembly to the wheel hub prior to installation on the spindle.

Figure 5.5

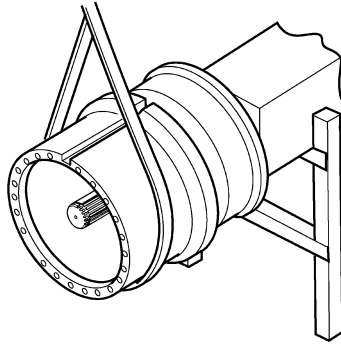
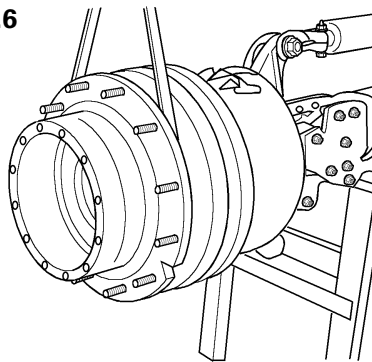

Figure 5.6







2. Install the ring gear hub assembly, which includes the outer bearing cone, on the spindle.
3. Install the wheel bearing adjusting nut on the spindle.
 - **If you temporarily attached the planetary ring gear hub assembly to the wheel hub in Step 1:** Remove the temporary capscrews from the ring gear hub.

Adjust the Wheel Bearing Preload

For wheel bearing adjustment procedures for axles equipped with wet disc brakes, refer to RICO Maintenance Manual 4L, Wet Disc Brakes. To order this publication, call Meritor's Customer Service Center at 800-535-5560.

Single Nut Design with Lockplates

1. Tighten the wheel bearing adjusting nut to the initial seating torque listed in **Table E**, while rotating the wheel hub. 
2. Continue to rotate the hub a minimum of one full revolution in both directions.
3. Tighten the wheel bearing adjusting nut again to the initial seating torque listed in **Table E**, while rotating the wheel hub in both directions. 
4. Repeat Steps 1 and 2 until the adjusting nut will not advance with the application of the initial seating nut torque. 
5. Loosen the adjusting nut 1/8 – 1/4 turn
6. Tighten the adjusting nut to the final adjustment nut torque listed in **Table E** while rotating the wheel hub. 

Section 5 Assembly

Table E: Single Wheel Bearing Adjustment

Rigid Axle Models	Steering Axle Models	Adjusting Nut Torque			
		Initial Seating		Final Adjustment	
		lb-ft	N•m	lb-ft	N•m
PRC594-PRC727	PSC594-PSC825	400	542	200	271
PRC1757	PSC826-PSC1617	400	542	350	474
PRLC824-PRLC1794	PSC1794	500	678	400	542

⚠ CAUTION

Do not loosen the adjusting nut when you install the adjusting nut lockplate. Loosening the adjusting nut from the setting in Step 6 can result in an incorrect bearing preload and damage to components.

- Use one of the following procedures to install the adjusting nut lockplate:
 - Place the flat side of the lockplate against a flat surface of the nut.
 - Place the lockplate notch over a corner of the adjusting nut. **Figure 5.7.**

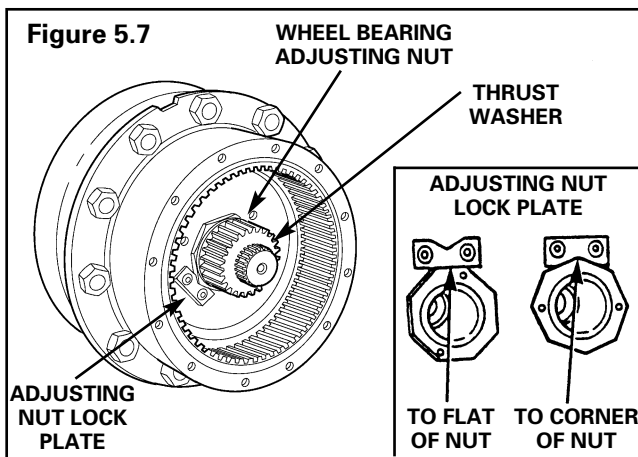

- If necessary, tighten the adjusting nut to align the lockplate holes with the threaded holes in the ring gear hub. Do not loosen the adjusting nut.

⚠ WARNING

Take care when you use Loctite® to avoid serious personal injury. Follow the manufacturer's instructions to prevent irritation to the eyes and skin.

- Install new lockplate capscrews with pre-applied locking agent on the threads. If you use the original capscrews, apply 2 or 3 drops of Loctite 277 or equivalent to the internal threads of the ring gear hub. Tighten the capscrews 60-75 lb-ft (81-102 N•m). **T**

Scalloped Flange Single Nut Design

- Tighten the wheel bearing adjusting nut to the initial seating torque listed in **Table E**, while rotating the wheel hub. **T**
- Continue to rotate the hub a minimum of one full revolution in both directions.
- Tighten the wheel bearing adjusting nut again to the initial seating torque listed in **Table E**, while rotating the wheel hub in both directions. **T**
- Repeat Steps 1 and 2 until the adjusting nut will not advance with the application of the initial seating nut torque. **T**
- Loosen the adjusting nut 1/8 – 1/4 turn
- Tighten the adjusting nut to the final adjustment nut torque listed in **Table E** while rotating the wheel hub. **T**

⚠ CAUTION

Do not loosen the adjusting nut when you install the capscrew. Loosening the adjusting nut from the setting in Step 6 can result in an incorrect bearing preload and damage to components.

- If necessary, tighten the adjusting nut to align a scallop with a threaded hole in the ring gear hub. Do not loosen the adjusting nut.



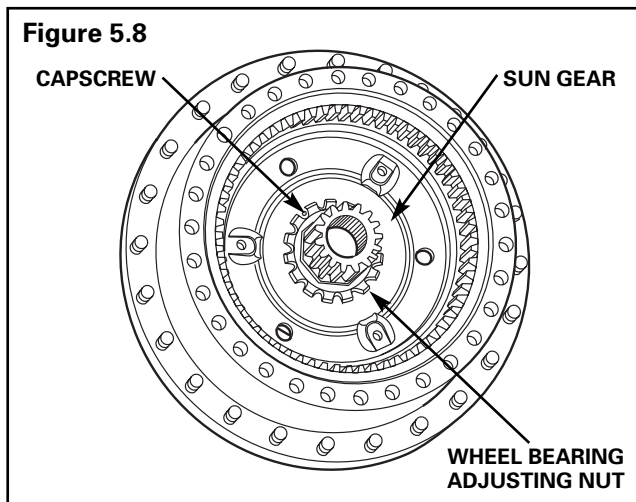

WARNING

Take care when you use Loctite® to avoid serious personal injury. Follow the manufacturer's instructions to prevent irritation to the eyes and skin.

8. Install the capscrew. Apply 2 or 3 drops of Loctite 242 or equivalent to the internal threads of the ring gear hub. Tighten the capscrew 20-30 lb-ft (27-40 N•m). **Figure 5.8.** 



Double Nut Design

1. Install the wheel bearing adjusting nut so that the nut lock faces **OUTWARD**. Installing the wheel bearing adjusting nut will seat the bearings and related components.
2. Tighten the nut to 400 lb-ft (542 N•m) while you rotate the hub in both directions. 
3. Tap the hub several times with a brass or plastic hammer.
4. Tighten the nut to 400 lb-ft (542 N•m). 
5. Loosen the adjusting nut to 0 lb-ft (0 N•m) to relieve the preload on the bearings.
6. Tighten the adjusting nut to 25 lb-ft (34 N•m). 
7. Install the nut lock ring washer. Ensure that the washer tang fits into the slot on the spindle and that the adjusting nut engages a washer hole.
8. Install the jam nut. Tighten the jam nut to 600-800 lb-ft (813-1085 N•m). 

Install the Planetary Ring Gear and Sun Gear

1. Apply grease to the inner face of the sun gear thrust washer (the side with tangs or dowel pins). Install the thrust washer so that the tangs or dowels engage the slots or holes in the wheel bearing adjusting nut.
2. Install the sun gear on the axle shaft and against the thrust washer. **Figure 5.7.**
3. Install the snap ring into the axle shaft groove.
4. Install the planetary ring gear onto the ring gear hub.

Assemble the Planetary Spider

RICO coverless spider planetary wheel ends come equipped with two different planetary designs.

- Planetary pinion shaft with needle roller bearings
- Nylon coated planetary pinion shafts

Refer to the correct assembly procedure for the type of planetary design you are servicing.

Planetary Pinion Shaft With Needle Roller Bearings

NOTE: For maximum planetary gear life, replace the pinion shafts and needle roller bearings on both wheel ends at the same time.

1. Separate the inner thrust washers from the outer thrust washers.
 - **To differentiate between the thrust washers:** Compare the washers' inner diameters. Outer thrust washers feature a larger inner diameter than inner thrust washers.
2. Apply approved O-617-A or -B, NLGI grade 1 or 2 grease to the side of the inner thrust washer opposite the tang.
3. Place the greased side of the inner thrust washer toward the planetary gear. The thrust washer tangs fit into the spider grooves.
4. Place the inner thrust washer on the end of the new planetary gear.
5. Apply approved O-617-A or -B, NLGI grade 1 or 2 grease to the planetary gear bore.

Section 5 Assembly

6. Install the needle roller bearings. Install new needle roller bearings if you replace the pinion shafts.
 - **To install the needle roller bearings:** Install a row of needle roller bearings around the pinion bore and against the inner thrust washer. Install as many needle roller bearings as will fit. The number of needle roller bearings installed in the pinion bore differs among axle models.
7. Place the spacer into the bore of the gear on top of the needle rollers. Install another row of needle rollers on top of the spacer.
8. Apply approved O-617-A or -B, NLGI grade 1 or 2 grease to the side of the outer thrust washer opposite the tang.
9. Place the outer thrust washer on the end of the planetary gear. The tang must align with the tang of the opposite washer.
10. Set the planetary spider on a level surface with the flange side facing UP. Carefully slide the loaded planetary gear assembly into the planetary spider. Ensure that the following conditions exist before you proceed to Step 11:
 - The outer thrust washer (large bore) must be on top of the gear assembly.
 - The washer tangs must fit in the planetary spider grooves.
 - The needle roller bearings must be in place.
11. Install the pinion shaft through the spider, the planetary gear and the thrust washers. Allow the pinion shaft to extend out from spider. Do not press the pinion shaft into the spider at this time. **Figure 5.9.**

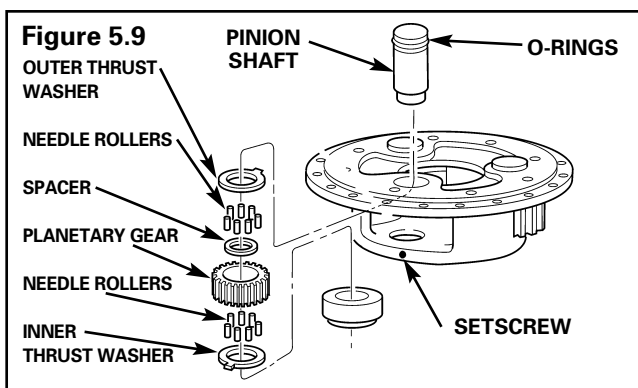

12. Repeat Steps 1-11 to install the second and third sets of pinion shafts, gears, needle roller bearings and thrust washers.
13. Check the alignment of the pinion shafts.
 - Place the spider cover over the shaft ends. When necessary, rotate the shafts so that spider cover fits over the flats. After you align the shafts, remove the cover.

! WARNING

Observe all WARNINGS and CAUTIONS provided by the press manufacturer concerning press operation to avoid serious personal injury and possible damage to components during assembly and installation procedures.

14. Install each pinion shaft into the spider gear assembly by hand.
 - **If you cannot install a pinion shaft into the spider gear assembly by hand:** Use a press to install the pinion shaft into the spider assembly until the shoulder of the shaft bottoms against the inner (bottom) thrust washer. When a press is not available, use a brass drift and mallet to install the pinion shafts.

Nylon Coated Planetary Pinion Shaft

1. Inspect the large bore chamfers. The chamfers must be smooth to prevent damage to the nylon coating on the planetary pinion shaft during installation.
 - **If the large bore chamfers are not smooth:** Use an emery cloth to clean the chamfer surface.
2. Install a new O-ring into the O-ring groove on the pinion shaft.
3. Inspect the planetary gear bores. Do not use planetary gears with rough bore surfaces.

! WARNING

Observe all WARNINGS and CAUTIONS provided by the press manufacturer concerning press operation to avoid serious personal injury and possible damage to components during assembly and installation procedures.

4. Place the spider in a press with the flange side UP. Support the spider as required.

5. Install the inner thrust washer (small bore). Place the washer tab into the spider indent and align the washer bore with the spider bore.
6. Apply a thin coat of the same gear lubricant used in the wheel end to the planetary gear bore.
7. Slide the planetary gear and the outer thrust washer into the spider. Align the bores of the parts and place the outer thrust washer tab into the spider indent.
8. Apply a thin coat of gear lube to the nylon coating on the pinion shaft.
9. Install the planetary pinion shaft in the spider and through the planetary gear and thrust washer. **Figure 5.10.**

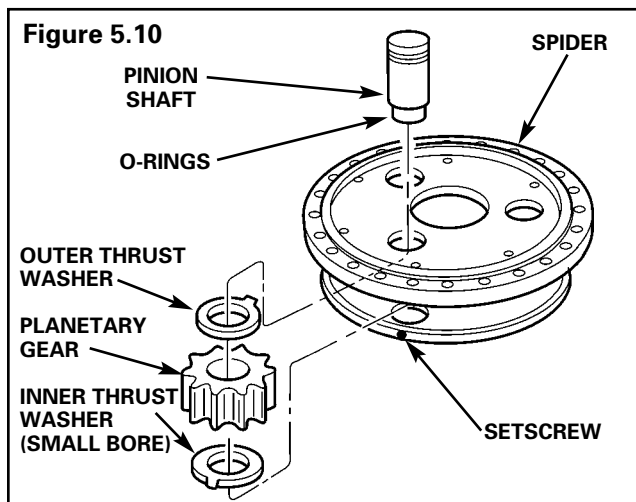

10. Repeat Steps 1-9 to install the second and third sets of planetary pinion shafts, gears and washers.
11. Install the set screw into the spider to secure the pinion shaft.

Install the Planetary Spider Assembly

WARNING

Take care when you use silicone gasket materials to avoid serious personal injury. Follow the manufacturer's instructions to prevent irritation to the eyes and skin.

CAUTION

Use only the correct gasket material. Do not use non-approved gasket material. Lubricant loss and damage to components can result.

1. Apply silicone (RTV) gasket material to the spider flange at the hub mounting face. Refer to "Applying Silicone Gasket Material" in Section 4.
2. Install the spider and pinion assembly in the wheel hub. Align the planetary gear teeth with the sun gear and ring gear teeth. Align the spider flange and wheel hub match marks you previously marked at disassembly. **Figure 5.11.**

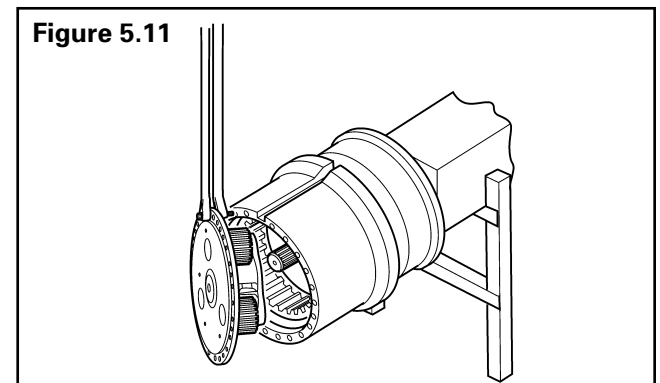

3. Correctly align the spider mounting holes with the wheel hub holes or studs. Push the spider assembly against the hub.
4. Install the nuts and washers or capscrews and washers.
 - **To install studs with integral hex and washers:** Use a 3.25-inch internal depth, extra deep socket.

Section 5 Assembly

- Tighten the wheel studs, capscrews or nuts according to the torque specifications shown in **Table F**. 

Table F: Planetary Spider Mounting Capscrew and Stud Torque Specifications

Size	Torque	
	lb-ft	N·m
1/2"-13	85-115	115-156
9/16"-12	130-165	176-224
5/8"-11, - 14	210-230	284-311
3/4"-10	310-400	420-542
7/8"-14	575-750	780-1017

Adjust the Brakes

Adjust the brakes for axles with P series and RSA drum brakes only.

- **For P series brakes:** Refer to Maintenance Manual 4, Cam Brakes.
- **For RSA brakes:** Refer to Maintenance Manual 4P, Off-Highway Heavy Duty Brakes.

To order these publications, call Meritor's Customer Service Center at 800-535-5560.

Install the Tires and Rims

- Install the tires and rims. Secure them with wheel rim clamps, nuts and washers.
- Tighten the wheel nuts according to the vehicle manufacturer's specifications.

Fill the Wheel Ends With Lubricant

- Rotate the wheel end until the oil fill line and oil level line are parallel to the ground.
- Lower the vehicle to the ground.
- Remove the oil fill plug from the cover. Clean all magnetic plugs and install the oil drain plug in the spider prior to filling the wheel end with lubricant.

NOTE: The rigid axle wheel end and housing bowl share the same oil and oil level.

- Fill each wheel-end and the axle housing bowl to the bottom of the fill/level plug hole with the specified oil. Do not fill oil through the bowl only.
- Wait for the oil to evenly flow through the axle.
- Check the oil level. Add oil if necessary.
- Replace and securely tighten all plugs.

Measure and Adjust the Toe Setting

Toe is the difference in distance between the front of the front tires and the rear of the front tires. **Figure 5.12**.

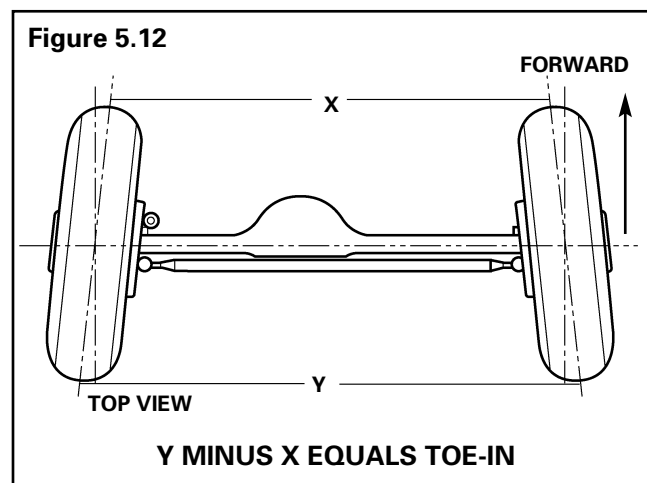

Check and adjust the toe setting after you install any of the following components:

- a front steering axle
- a new steering knuckle
- a tie rod component

RICO performs the toe adjustment with the axle in an unloaded condition.

The toe specification for RICO off-highway steering axles is 1/16-inch (1.60 mm) toe-in [\pm 1/16-inch (1.60 mm)]. This specification is based on a 24-inch (60.96 cm) radius (theoretical tire with a 48-inch (121.92 cm) outside diameter).

Tire Matching for Tandem and Tridem Axles

CAUTION

Unmatched tires on both tandem drive units and tridem drive units will cause tire wear and scuffing and possible damage to the drive units. RICO recommends that the tires be matched to within 1/8-inch (3.18 mm) of the same rolling radius, 3/4-inch (19.05 mm) of the same rolling circumference.

Tandem Axles

The four largest tires should never be installed on one driving axle or the four smallest tires on the other driving axle. Such tire mounting will cause an interaxle “fight,” unusually high axle lubricant temperatures that result in premature lubricant breakdown and possible costly axle service.

In addition to matching individual tire rolling radii or rolling circumference, RICO recommends matching, as nearly as possible, the total tire circumference of one driving axle to the total tire circumference of the other driving axle. This will usually result in satisfactory tandem axle lubricant temperatures that lengthen drive unit service with higher tire mileage.

Park the vehicle on a level surface. The vehicle must carry a correctly distributed rated capacity load. All the tires must be the same size. Measure new tires to verify that they will be correctly matched.

1. Inflate all tires to the same pressure.
2. Carefully measure the rolling circumference of each tire with a steel tape.
3. Mark the size on each tire with chalk and arrange the tires in order of size, largest to smallest.
4. Mount the two largest tires on one side of one axle and mount the two smallest on the opposite side of the same axle.
5. Mount the four other tires on the other axle in the same manner.
6. Test run the vehicle to gather accurate rear axle lubricant temperature readings on the two axle lubricant temperature gauges.
7. Vary tire air pressure within the tire manufacturer's recommended range so the lubricant temperature of both axles is within 30°F (-1°C) of each other and not in excess of 200°F (93°C). This will usually result in uniform tire loading and good tire life.

Tridem Axles

When three driving axles are “hooked” together in a tridem series, unmatched tires will compound the problems described in the preceding paragraphs. RICO recommends matching, as nearly as possible, the total tire circumference of each of the three driving axles.

To match tires on tridem units, follow the same procedure used for tandem units.

Arrange the tires in order of size:

- The two largest and two smallest go on one axle.
- The next two largest and smallest go on the second axle.
- The remaining four tires go on the third axle.

Notes

Section 6 Lubrication

Lubrication Schedule

Operation	Off-Highway ^①
Initial Oil Change	100 operating hours ^①
Check Oil Level	250 operating hours ^①
Petroleum Oil Change	1,500 operating hours or twice a year (whichever comes first) ^①
Synthetic Oil or Semi-Synthetic Oil Change	3,000 operating hours or once a year (whichever comes first)

^① The interval depends on the individual operating conditions, speeds and loads. Severe operating conditions may require more frequent intervals.

Lubricant Specifications

RICO Specifications	Military Specification Approval	Oil Description	Outside Temperature			
			°F		°C	
			Min.	Max.	Min.	Max.
O-76A, Gear Oil	MIL-L-2105D or MIL-PRF-2105-E	GL-5, SAE 85W/140	10	None	-12	None
O-76D, Gear Oil		GL-5, SAE 80W/90	-15	None	-26	None
O-76E, Gear Oil		GL-5, SAE 75W/90	-40	None	-40	None
O-76L, Gear Oil		GL-5, SAE 75W/140	-40	None	-40	None
O-76M, Gear Oil		GL-5, SAE 75W/140	-40	None	-40	None
O-76N, Gear Oil		GL-5, SAE 75W/140	-40	None	-40	None

Notes

Rigid Axle Wet Disc Brake

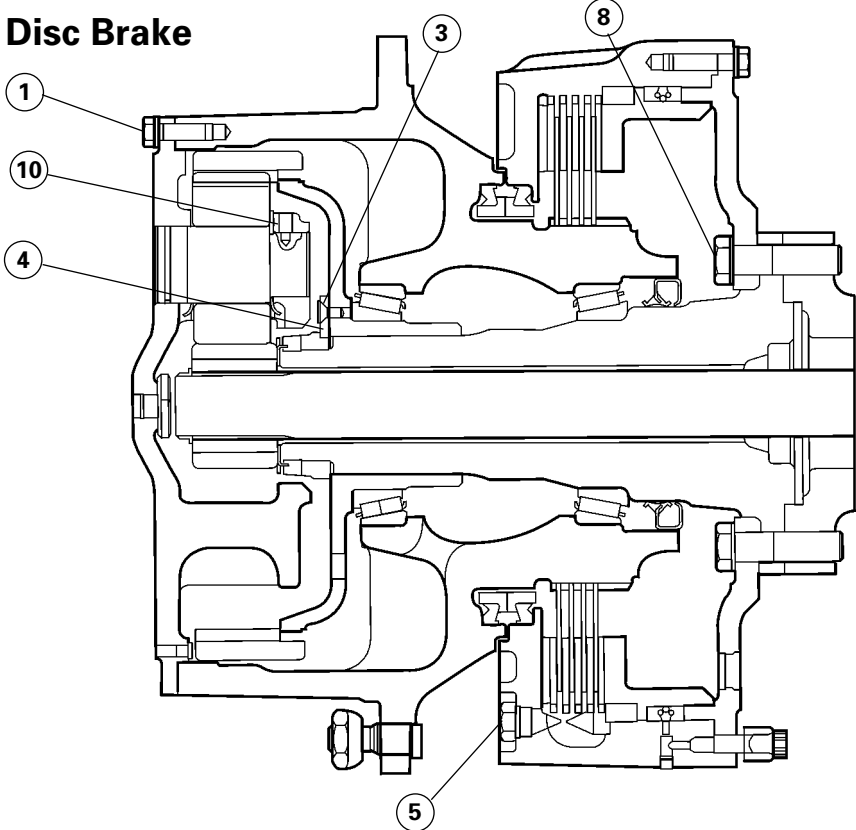

Rigid Axle Drum Brake

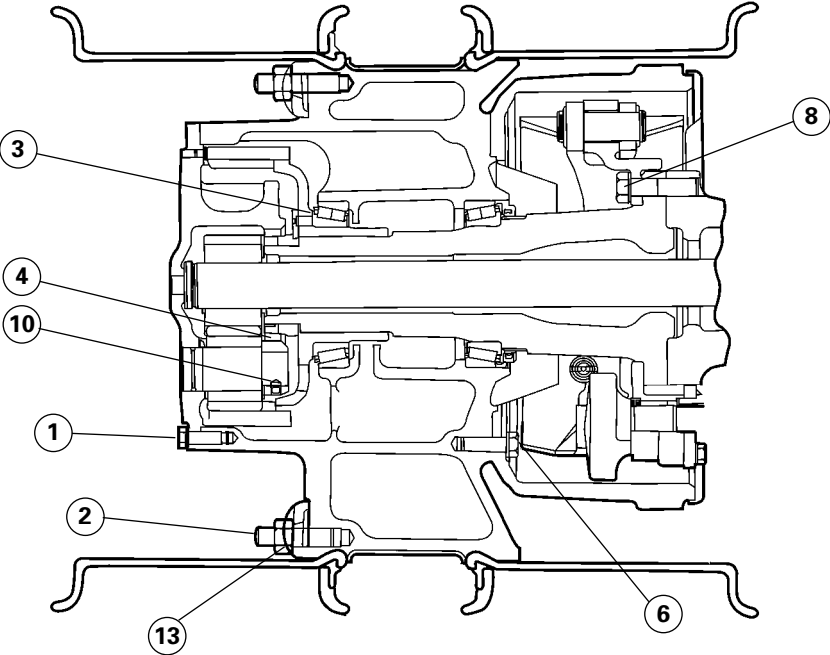

Section 7 Specifications

Rigid Axle Dry Disc Brake

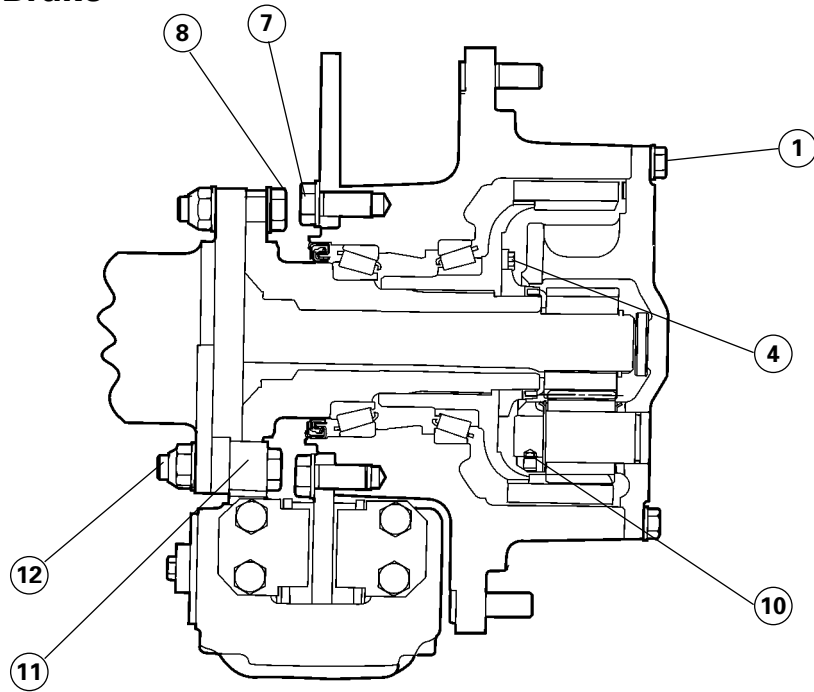

Steering Axle Dry Disc Brake

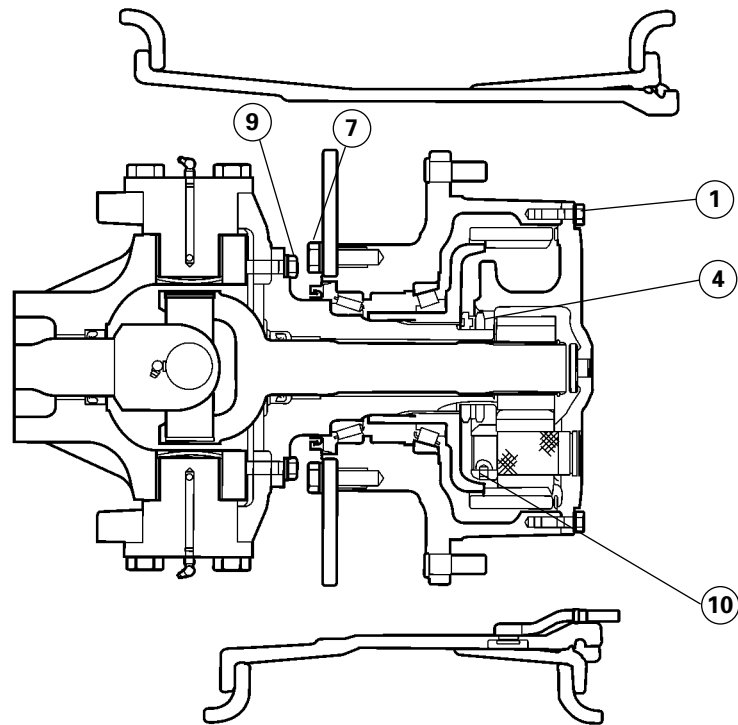

Section 7 Specifications

Planetary Axle Wheel End Torque Specifications

Item	Fastener Description	Size	Torque	
			lb-ft	N•m
1	Planetary Spider Mounting Capscrew	1/2"-13	85-115	115-156
		9/16"-12	130-165	176-224
		5/8"-11, -14	210-230	284-311
		3/4"-10	310-400	420-542
		7/8"-14	575-750	780-1017
2	Wheel Stud Nut	3/4"-10	310-400	420-542
		7/8"-14	575-750	780-1017
3	Lockplate Capscrew	3/8"-16	30-45	41-61
4	Wheel Bearing Adjusting Nut	Refer to "Adjusting the Wheel Bearing Preload" in Section 5.		
5	Wet Brake Driver Mounting Capscrew	7/8"-14	575-750	780-1017
		1"-12	850-1100	1152-1491
6	Brake Drum Mounting Capscrew	5/8"-11, -18	210-230	284-311
		9/16"-18	130-165	172-224
		3/4"-10	310-400	420-542
		7/8"-14	575-750	780-1017
7	Brake Rotor Mounting Capscrew	1/2"-12	85-115	115-156
		9/16"-18	130-165	176-224
		5/8"-11, -18	210-230	284-311
		3/4"-10	310-400	420-542
		7/8"-9, -14	575-650	779-880
		1"-12, -14	850-1100	1152-1491
8	Spindle Mounting Capscrew (Nut on Stud)	1/2"-12	85-115	115-156
		9/16"-18	130-165	176-224
		5/8"-11, -18	210-230	284-311
		3/4"-10	310-400	420-542
		7/8"-9, -14	575-650	779-880
		1"-12, -14	850-1100	1152-1491
9	Spindle to Steer Knuckle Capscrew	1/2"-13	85-115	115-156
		5/8"-11	210-230	284-311
		9/16"-12	130-165	176-224
		7/8"-14	575-750	780-1017
10	Pinion Shaft Locknut	3/8"-16	30-45	41-61
11	Caliper Adapter to Spindle Bolt	7/8"-9	440-580	597-786
12	Caliper to Adapter Capscrew	3/4"-10	310-400	420-542
		M20	369-479	500-650
13	Wheel Rim Clamp Nut	Refer to OEM specifications		
	Oil Level/Drain Plug (Not Shown)	3/4"-14	35	47
	Planetary Ring Gear Lock Capscrew (Not Shown)	3/8"-16	35-50	47-68
		7/16"-14	60-75	81-102

Wet Disc Brake with Dowel Pins

Model W3H (360 mm)

Maintenance Manual MM-20195



W3H (360 mm)

Service Notes

Before You Begin

This manual provides maintenance and service procedures for Meritor's W3H 360 mm wet disc brake with dowel pins. While this manual cannot cover all possible wheel end combinations, it shows two typical wheel ends:

- A wheel end with the outer bearing assembled on the ring gear hub journal (such as the PRC 775 wheel end).
- A wheel end with the outer bearing assembled on the spindle journal (such as the PRC 425 wheel end).

Before you begin procedures:

1. Read and understand all instructions and procedures before you begin to service components.
2. Read and observe all Caution and Warning safety alerts that precede instructions or procedures you will perform. These alerts help to avoid damage to components, serious personal injury, or both.
3. Follow your company's maintenance and service, installation, and diagnostics guidelines.
4. Use special tools when required to help avoid serious personal injury and damage to components.

Safety Alerts, Torque Symbol and Notes



 WARNING	A Warning alerts you to an instruction or procedure that you must follow exactly to avoid serious personal injury and damage to components.
 CAUTION	A Caution alerts you to an instruction or procedure that you must follow exactly to avoid damage to components and possible serious personal injury can also occur.
	The torque symbol alerts you to tighten fasteners to a specified torque value.
NOTE:	A Note provides information or suggestions that help you correctly service a component.

Table of Contents

 Asbestos and Non-Asbestos Fibers Warnings	1
Section 1: Exploded View	
W3H – 360mm Wet Disc Brake with Dowel Pins.....	2
Wheel End with Outer Bearing on Ring Gear Hub Journal	3
Wheel End with Outer Bearing on Spindle Journal	4
Section 2: Introduction	
Description.....	5
Wheel End with Outer Bearing on Ring Gear Hub Journal Cooling Systems	
Wheel End with Outer Bearing on Spindle Journal	6
Cooling Systems	
How to Identify the Brake Model.....	7
Section 3: Disassembly	
Removal – Wet Disc Brake	8
Drain Fluids from Wheel Ends	
Wheel End with Outer Bearing on Ring Gear Hub Journal	10
Wheel End with Outer Bearing on Spindle Journal	12
Brake Disc Housing Assembly – Wheel End	13
Brake Piston Housing Assembly	14
Brake Piston Housing and Wheel Spindle.....	15
Section 4: Inspection	16
Section 5: Prepare Parts for Assembly	
Clean Components Prior to Assembly.....	18

Table of Contents

Section 6: Assembly

Installation – Wheel Spindle	19
Brake Piston Housing	20
Piston Assembly	21
Brake Disc Housing	22
Duo-Cone Face Seal into Brake Disc Housing and into Hub.....	23
Check for Correct Installation of the Duo-Cone Seal	25
Wheel Hub to Brake Disc Housing	26
Adjustment – Wheel Bearing Preload – Wheel End with Outer Bearing on Ring Gear Hub Journal ...	27
Wheel Bearing Preload – Wheel End with Outer Bearing on Spindle Journal.....	28
Fill Wet Brake Assembly with Required Coolant	29
Adjust Brake with New Disc Pack	
Remove Air from the System (“Bleed” the Brakes)	30
Air/Hydraulic or Mechanical Actuator Systems	
Full Hydraulic Systems	

Section 7: Maintenance

Coolant Change Intervals.....	31
Coolant Draining and Filling	

Section 8: Troubleshooting

Brake Does Not Apply	33
Brake Does Not Release	
Braking Performance	
Brake Leaks Actuation Fluid	34
Brake Cooling Fluid Leakage	
Brake Noise and Vibration	
Brake Overheats	35

Section 9: Specifications

Plug and Screw Torque on Brake Piston Housing.....	36
W3H Wheel End Torque Chart for the PRC 775	37
W3H Wheel End Torque Chart for the PRC 425	38
Minimum Brake Disc Thickness	39
Hydraulic Fluid for Brake Actuation	
Brake Coolant Specifications: Sump and Forced Cooling Systems with Hub Seals	
Coolant Change Intervals	
Hydraulic Fluid Specifications	

Asbestos and Non-Asbestos Fibers



ASBESTOS FIBER WARNING

The following procedures for servicing brakes are recommended to reduce exposure to asbestos fiber dust, a cancer and lung disease hazard. Material Safety Data Sheets are available from RICO.

Hazard Summary

Because some brake linings contain asbestos, workers who service brakes must understand the potential hazards of asbestos and precautions for reducing risks. Exposure to airborne asbestos dust can cause serious and possibly fatal diseases, including asbestosis (a chronic lung disease) and cancer, principally lung cancer and mesothelioma (a cancer of the lining of the chest or abdominal cavities). Some studies show that the risk of lung cancer among persons who smoke and who are exposed to asbestos is much greater than the risk for non-smokers. Symptoms of these diseases may not become apparent for 15, 20 or more years after the first exposure to asbestos.

Accordingly, workers must use caution to avoid creating and breathing dust when servicing brakes. Specific recommended work practices for reducing exposure to asbestos dust follow. Consult your employer for more details.

Recommended Work Practices

1. **Separate Work Areas.** Whenever feasible, service brakes in a separate area away from other operations to reduce risks to unprotected persons. OSHA has set a maximum allowable level of exposure for asbestos of 0.1 f/cc as an 8-hour time-weighted average and 1.0 f/cc averaged over a 30-minute period. Scientists disagree, however, to what extent adherence to the maximum allowable exposure levels will eliminate the risk of disease that can result from inhaling asbestos dust. OSHA requires that the following sign be posted at the entrance to areas where exposures exceed either of the maximum allowable levels:

**DANGER: ASBESTOS
CANCER AND LUNG DISEASE HAZARD
AUTHORIZED PERSONNEL ONLY
RESPIRATORS AND PROTECTIVE CLOTHING
ARE REQUIRED IN THIS AREA**

2. **Respiratory Protection.** Wear a respirator equipped with a high-efficiency (HEPA) filter approved by NIOSH or MSHA for use with asbestos at all times when servicing brakes, beginning with the removal of the wheels.

3. **Procedures for Servicing Brakes.**

- a. Enclose the brake assembly within a negative pressure enclosure. The enclosure should be equipped with a HEPA vacuum and worker arm sleeves. With the enclosure in place, use the HEPA vacuum to loosen and vacuum residue from the brake parts.
- b. As an alternative procedure, use a catch basin with water and a biodegradable, non-phosphate, water-based detergent to wash the brake drum or rotor and other brake parts. The solution should be applied with low pressure to prevent dust from becoming airborne. Allow the solution to flow between the brake drum and the brake support or the brake rotor and caliper. The wheel hub and brake assembly components should be thoroughly wetted to suppress dust before the brake shoes or brake pads are removed. Wipe the brake parts clean with a cloth.
- c. If an enclosed vacuum system or brake washing equipment is not available, employers may adopt their own written procedures for servicing brakes, provided that the exposure levels associated with the employer's procedures do not exceed the levels associated with the enclosed vacuum system or brake washing equipment. Consult OSHA regulations for more details.

d. Wear a respirator equipped with a HEPA filter approved by NIOSH or MSHA for use with asbestos when grinding or machining brake linings. In addition, do such work in an area with a local exhaust ventilation system equipped with a HEPA filter.

e. **NEVER** use compressed air by itself, dry brushing, or a vacuum not equipped with a HEPA filter when cleaning brake parts or assemblies. **NEVER** use carcinogenic solvents, flammable solvents, or solvents that can damage brake components as wetting agents.

4. **Cleaning Work Areas.** Clean work areas with a vacuum equipped with a HEPA filter or by wet wiping. **NEVER** use compressed air or dry sweeping to clean work areas. When you empty vacuum cleaners and handle used rags, wear a respirator equipped with a HEPA filter approved by NIOSH or MSHA for use with asbestos. When you replace a HEPA filter, wet the filter with a fine mist of water and dispose of the used filter with care.

5. **Worker Clean-Up.** After servicing brakes, wash your hands before you eat, drink or smoke. Shower after work. Do not wear work clothes home. Use a vacuum equipped with a HEPA filter to vacuum work clothes after they are worn. Launder them separately. Do not shake or use compressed air to remove dust from work clothes.

6. **Waste Disposal.** Dispose of discarded linings, used rags, cloths and HEPA filters with care, such as in sealed plastic bags. Consult applicable EPA, state and local regulations on waste disposal.

Regulatory Guidance

References to OSHA, NIOSH, MSHA, and EPA, which are regulatory agencies in the United States, are made to provide further guidance to employers and workers employed within the United States. Employers and workers employed outside of the United States should consult the regulations that apply to them for further guidance.



NON-ASBESTOS FIBERS WARNING

The following procedures for servicing brakes are recommended to reduce exposure to non-asbestos fiber dust, a potential cancer and lung disease hazard. Material Safety Data Sheets are available from RICO.

Hazard Summary

Most recently manufactured brake linings do not contain asbestos fibers. These brake linings may contain one or more of a variety of ingredients, including glass fibers, mineral wool, aramid fibers, ceramic fibers and silica that can present health risks if inhaled. Scientists disagree on the extent of the risks from exposure to these substances. Nonetheless, exposure to silica dust can cause silicosis, a non-cancerous lung disease. Silicosis gradually reduces lung capacity and efficiency and can result in serious breathing difficulty. Some scientists believe other types of non-asbestos fibers, when inhaled, can cause similar diseases of the lung. In addition, silica dust and ceramic fiber dust are known to the State of California to cause lung cancer. U.S. and international agencies have also determined that dust from mineral wool, ceramic fibers and silica are potential causes of cancer.

Accordingly, workers must use caution to avoid creating and breathing dust when servicing brakes. Specific recommended work practices for reducing exposure to non-asbestos dust follow. Consult your employer for more details.

Recommended Work Practices

1. **Separate Work Areas.** Whenever feasible, service brakes in a separate area away from other operations to reduce risks to unprotected persons.

2. **Respiratory Protection.** OSHA has set a maximum allowable level of exposure for silica of 0.1 mg/m³ as an 8-hour time-weighted average. Some manufacturers of non-asbestos brake linings recommend that exposures to other ingredients found in non-asbestos brake linings be kept below 1.0 f/cc as an 8-hour time-weighted average. Scientists disagree, however, to what extent adherence to these maximum allowable exposure levels will eliminate the risk of disease that can result from inhaling non-asbestos dust.

Therefore, wear respiratory protection at all times during brake servicing, beginning with the removal of the wheels. Wear a respirator equipped with a high-efficiency (HEPA) filter approved by NIOSH or MSHA, if the exposures levels may exceed OSHA or manufacturer's recommended maximum levels. Even when exposures are expected to be within the maximum allowable levels, wearing such a respirator at all times during brake servicing will help minimize exposure.

3. **Procedures for Servicing Brakes.**

- a. Enclose the brake assembly within a negative pressure enclosure. The enclosure should be equipped with a HEPA vacuum and worker arm sleeves. With the enclosure in place, use the HEPA vacuum to loosen and vacuum residue from the brake parts.
- b. As an alternative procedure, use a catch basin with water and a biodegradable, non-phosphate, water-based detergent to wash the brake drum or rotor and other brake parts. The solution should be applied with low pressure to prevent dust from becoming airborne. Allow the solution to flow between the brake drum and the brake support or the brake rotor and caliper. The wheel hub and brake assembly components should be thoroughly wetted to suppress dust before the brake shoes or brake pads are removed. Wipe the brake parts clean with a cloth.

c. If an enclosed vacuum system or brake washing equipment is not available, carefully clean the brake parts in the open air. Wet the parts with a solution applied with a pump-spray bottle that creates a fine mist. Use a solution containing water, and, if available, a biodegradable, non-phosphate, water-based detergent. The wheel hub and brake assembly components should be thoroughly wetted to suppress dust before the brake shoes or brake pads are removed. Wipe the brake parts clean with a cloth.

d. Wear a respirator equipped with a HEPA filter approved by NIOSH or MSHA when grinding or machining brake linings. In addition, do such work in an area with a local exhaust ventilation system equipped with a HEPA filter.

e. **NEVER** use compressed air by itself, dry brushing, or a vacuum not equipped with a HEPA filter when cleaning brake parts or assemblies. **NEVER** use carcinogenic solvents, flammable solvents, or solvents that can damage brake components as wetting agents.

4. **Cleaning Work Areas.** Clean work areas with a vacuum equipped with a HEPA filter or by wet wiping. **NEVER** use compressed air or dry sweeping to clean work areas. When you empty vacuum cleaners and handle used rags, wear a respirator equipped with a HEPA filter approved by NIOSH or MSHA, to minimize exposure. When you replace a HEPA filter, wet the filter with a fine mist of water and dispose of the used filter with care.

5. **Worker Clean-Up.** After servicing brakes, wash your hands before you eat, drink or smoke. Shower after work. Do not wear work clothes home. Use a vacuum equipped with a HEPA filter to vacuum work clothes after they are worn. Launder them separately. Do not shake or use compressed air to remove dust from work clothes.

6. **Waste Disposal.** Dispose of discarded linings, used rags, cloths and HEPA filters with care, such as in sealed plastic bags. Consult applicable EPA, state and local regulations on waste disposal.

Regulatory Guidance

References to OSHA, NIOSH, MSHA, and EPA, which are regulatory agencies in the United States, are made to provide further guidance to employers and workers employed within the United States. Employers and workers employed outside of the United States should consult the regulations that apply to them for further guidance.

Section 1 Exploded View

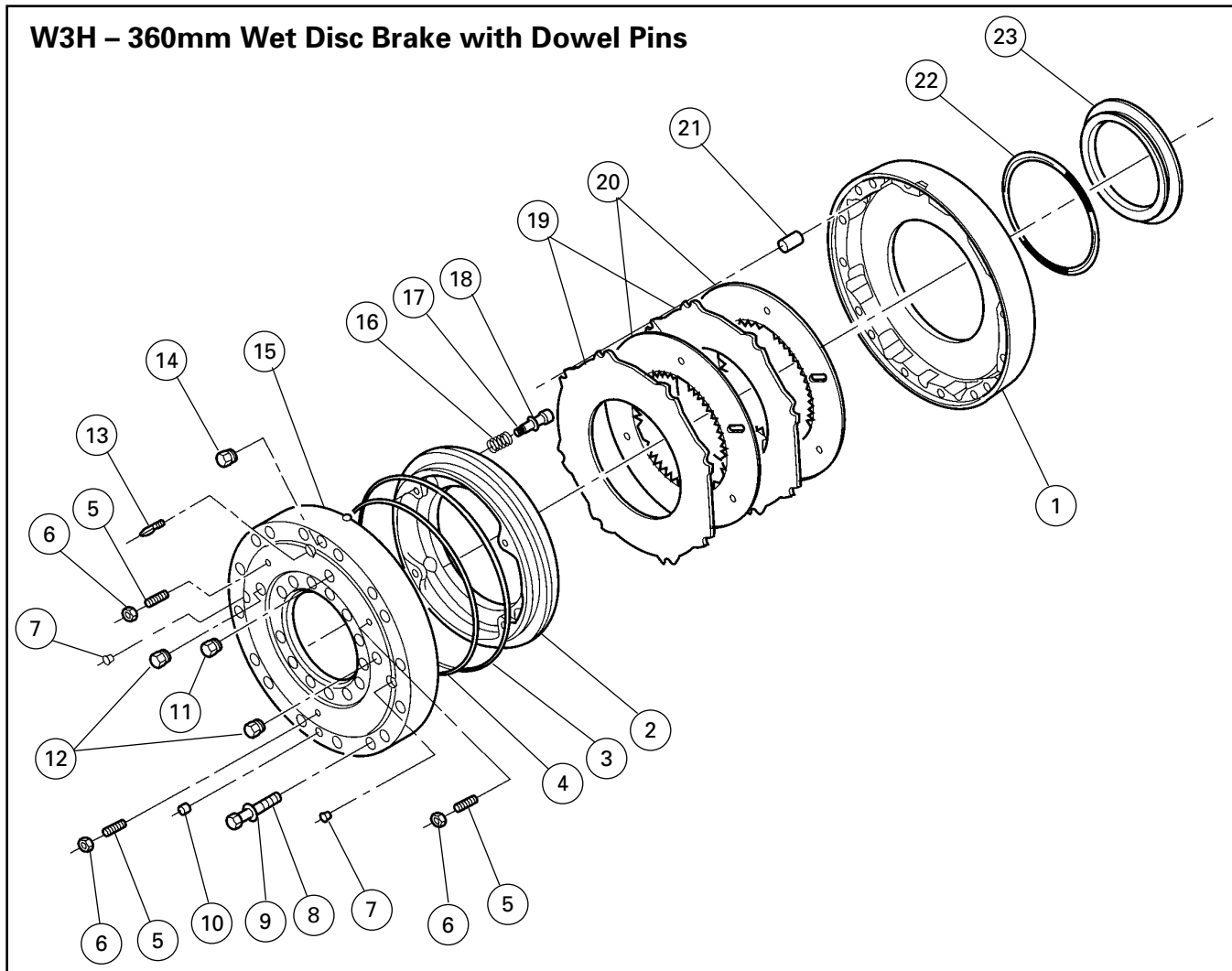

ITEM	DESCRIPTION	ITEM	DESCRIPTION
1	Housing, Brake Disc	13	Screw, Brake Bleeder
2	Piston	14	Plug Assembly, Forced Cooling Inlet
3	Seal, Piston Outer (large)	15	Housing, Piston
4	Seal, Piston Inner (small)	16	Spring, Piston Return
5	Screw, Brake Adjuster	17	Bolt, Shoulder
6	Jam Nut, Brake Adjuster	18	Washer, Hardened
7	Plug Assembly, Service Brake Inlet	19	Disc, Stationary
8	Capscrew	20	Disc Assembly, Friction
9	Washer, Hardened	21	Dowel Pin, Stationary Disc Locking
10	Plug, Magnetic Drain	22	Toric Seal Ring
11	Plug Assembly, Air Evacuation	23	Duo-Cone Face Seal Half
12	Plug Assembly, Forced Cooling Outlet		

Section 1 Exploded View

**Wheel End with Outer Bearing
on Ring Gear Hub Journal
(PRC 775 W3H shown as example)**

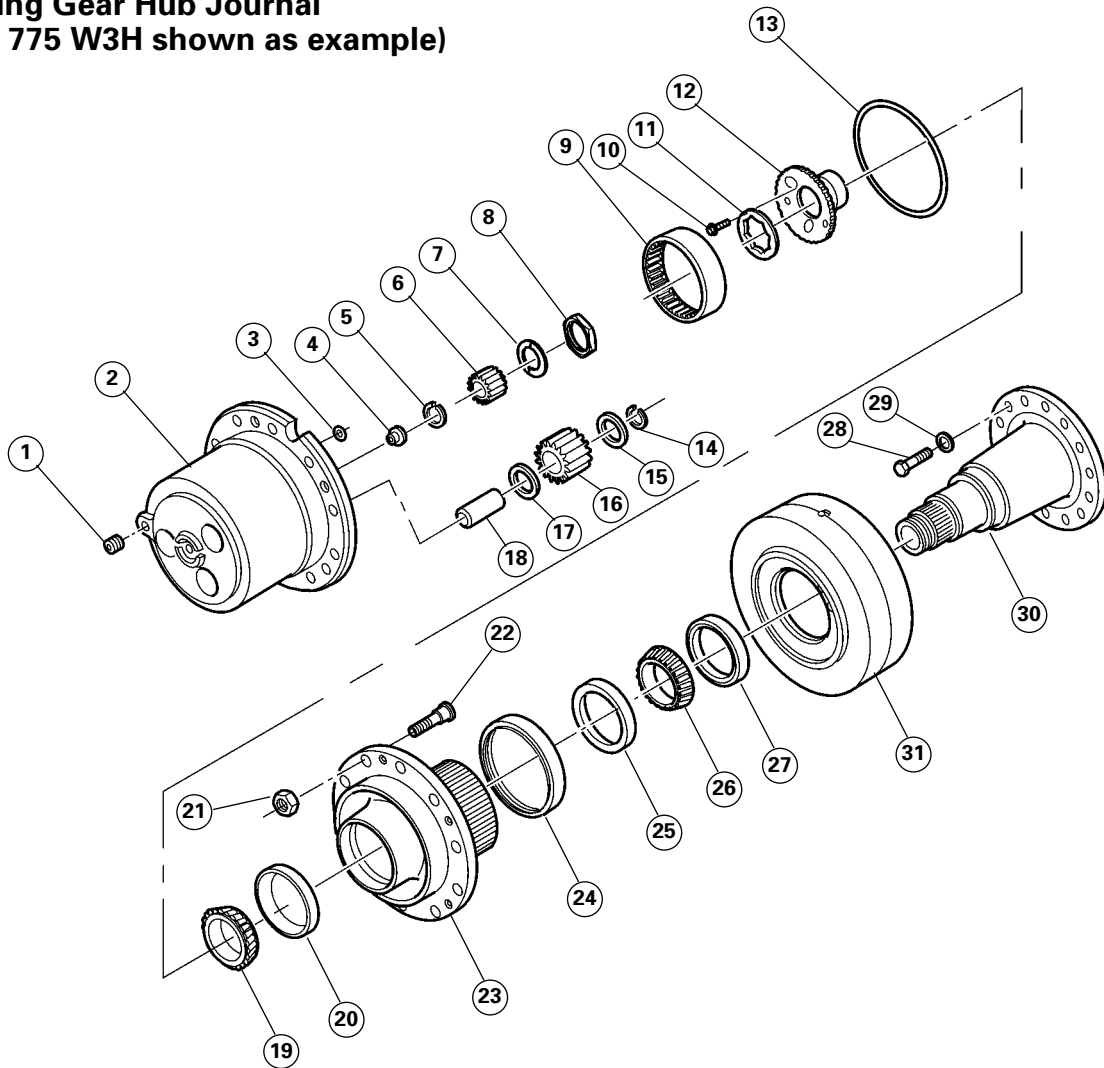

ITEM	DESCRIPTION	ITEM	DESCRIPTION	ITEM	DESCRIPTION
1	Magnetic Drain Fill Plug	12	Planetary Ring Gear Hub	22	Wheel Stud
2	Planetary Spider	13	O-Ring	23	Hub
3	Thrust Button	14	Snap Ring	24	Face Seal Assembly
4	Thrust Button	15	Inner Thrust Washer	25	Inner Bearing Cup
5	Snap Ring	16	Planetary Pinion Gear	26	Inner Bearing Cone
6	Planetary Sun Gear	17	Outer Thrust Washer	27	Oil Seal Assembly
7	Thrust Washer	18	Pinion Shaft	28	Capscrew
8	Adjusting Nut	18A	O-Ring (on pinion shaft)	29	Flat Washer
9	Planetary Ring Gear	19	Outer Bearing Cone	30	Spindle
10	Capscrew	20	Outer Bearing Cup	31	Wet Disc Brake Assembly
11	Lock	21	Wheel Nut		

Section 1 Exploded View

**Wheel End with Outer Bearing on Spindle Journal
(PRC 425 W3H shown as example)**

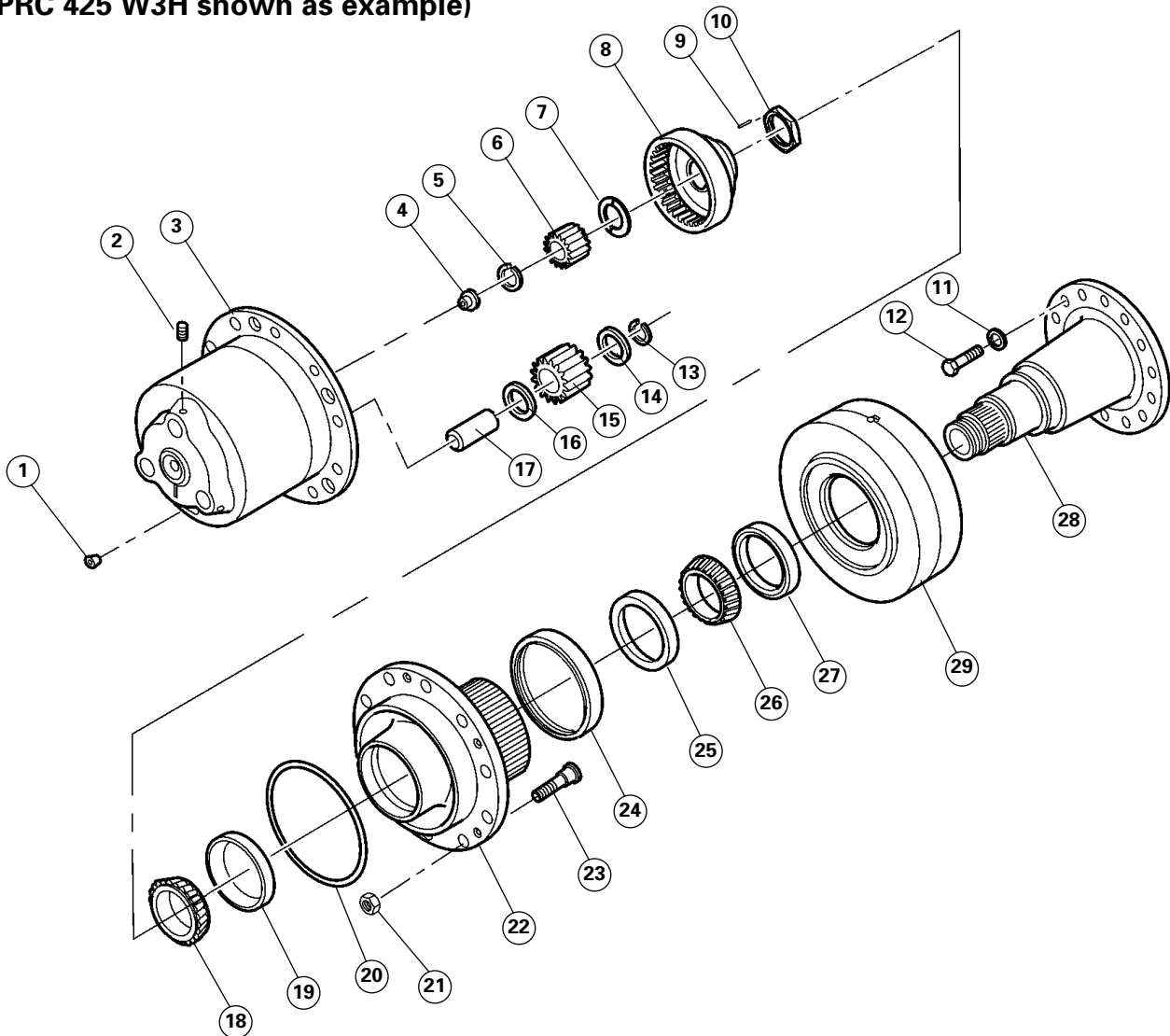

ITEM	DESCRIPTION	ITEM	DESCRIPTION	ITEM	DESCRIPTION
1	Magnetic Drain/Fill Plug	11	Flat Washer	21	Wheel Nut
2	Setscrew	12	Capscrew	22	Hub
3	Planetary Spider	13	Snap Ring	23	Wheel Stud
4	Thrust Button	14	Inner Thrust Washer	24	Face Seal Assembly
5	Snap Ring	15	Planetary Pinion Gear	25	Inner Bearing Cup
6	Planetary Sun Gear	16	Outer Thrust Washer	26	Inner Bearing Cone
7	Thrust Washer	17	Planetary Pinion Shaft	27	Oil Seal Assembly
8	Planetary Ring Gear	18	Outer Bearing Cone	28	Spindle
9	Pin	19	Outer Bearing Cup	29	Wet Disc Brake Assembly
10	Adjusting Nut	20	O-Ring		

Cross Section – Wheel End with Outer Bearing on Ring Gear Hub Journal (PRC 775 shown as example)

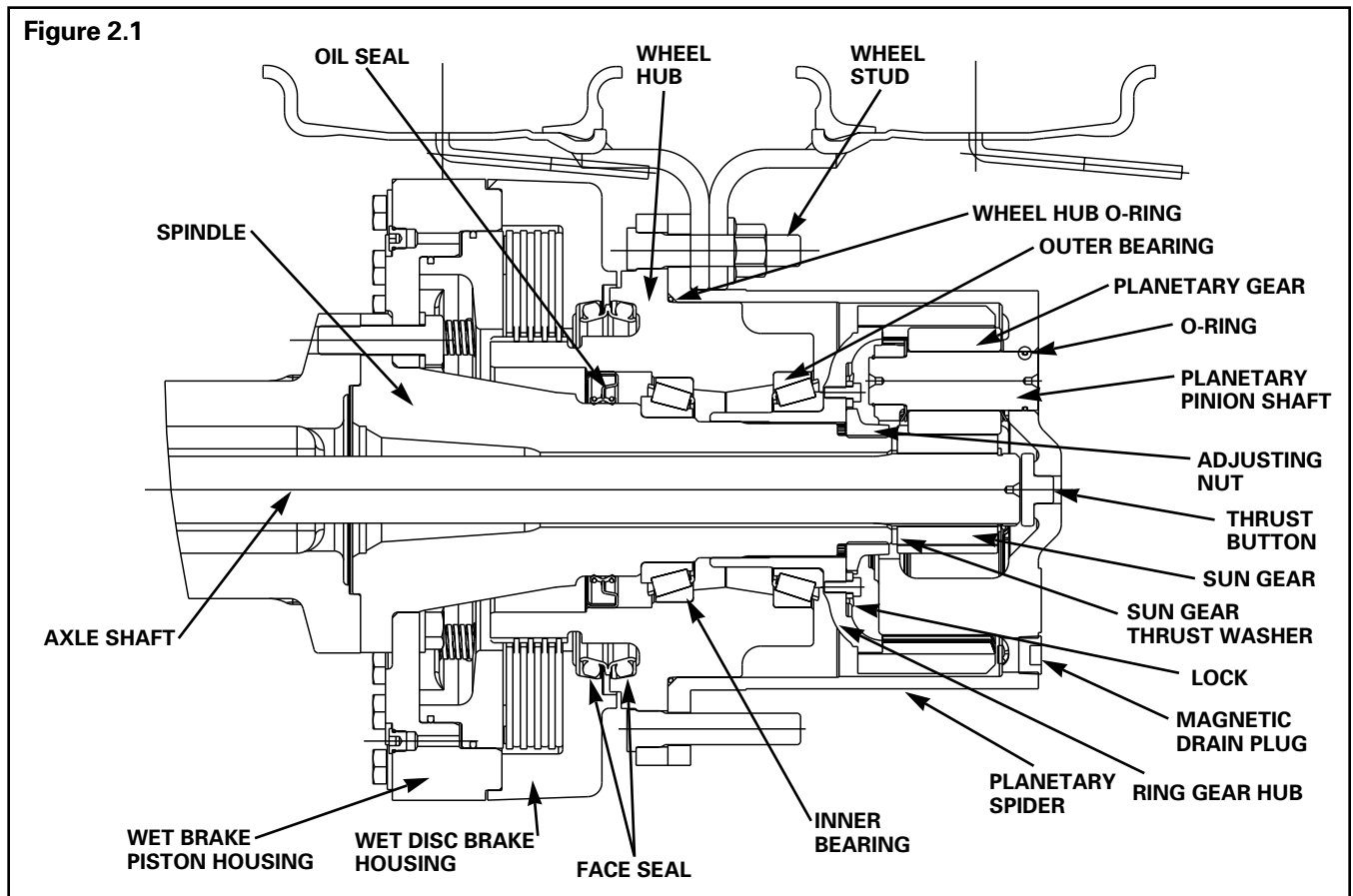

Description

Wheel End with Outer Bearing on Ring Gear Hub Journal

The W3H – 360 mm Dura-Disc wet disc brake is a hydraulically actuated friction brake. **Figure 2.1** shows the wet disc brake installed on the PRC 775 axle, which has a wheel end with outer bearing installed on the ring gear hub journal.

Four friction discs and four stationary discs are used in the wet disc brake for this type of wheel end.

- Friction discs rotate with the wheel hub.
- Stationary discs are locked to the brake housing with dowel pins.

The W3H – 360 mm wet disc brake uses a two-piece housing. The outer brake housing contains the discs, while the inner brake housing contains the piston and the piston seals.

Cooling Systems

⚠ CAUTION

The operating temperature of the coolant must never reach or exceed 250°F (120°C). If the operating temperature of the coolant reaches or exceeds 250°F (120°C), the internal components of the brake will be damaged. A forced cooling system may be required to assure that the coolant temperature remains below 250°F (120°C).

A forced cooling system is used. The forced cooling system removes more heat from the discs than a sump cooling system. An external pump moves hydraulic fluid from a reservoir to the brake housing and back to the reservoir.

Hub seals on forced cooling systems separate the brake's coolant from the lubricant in the planetary wheel end.

Section 2 Introduction

Cross Section – Wheel End with Outer Bearing on Spindle Journal (PRC 425 shown as example)

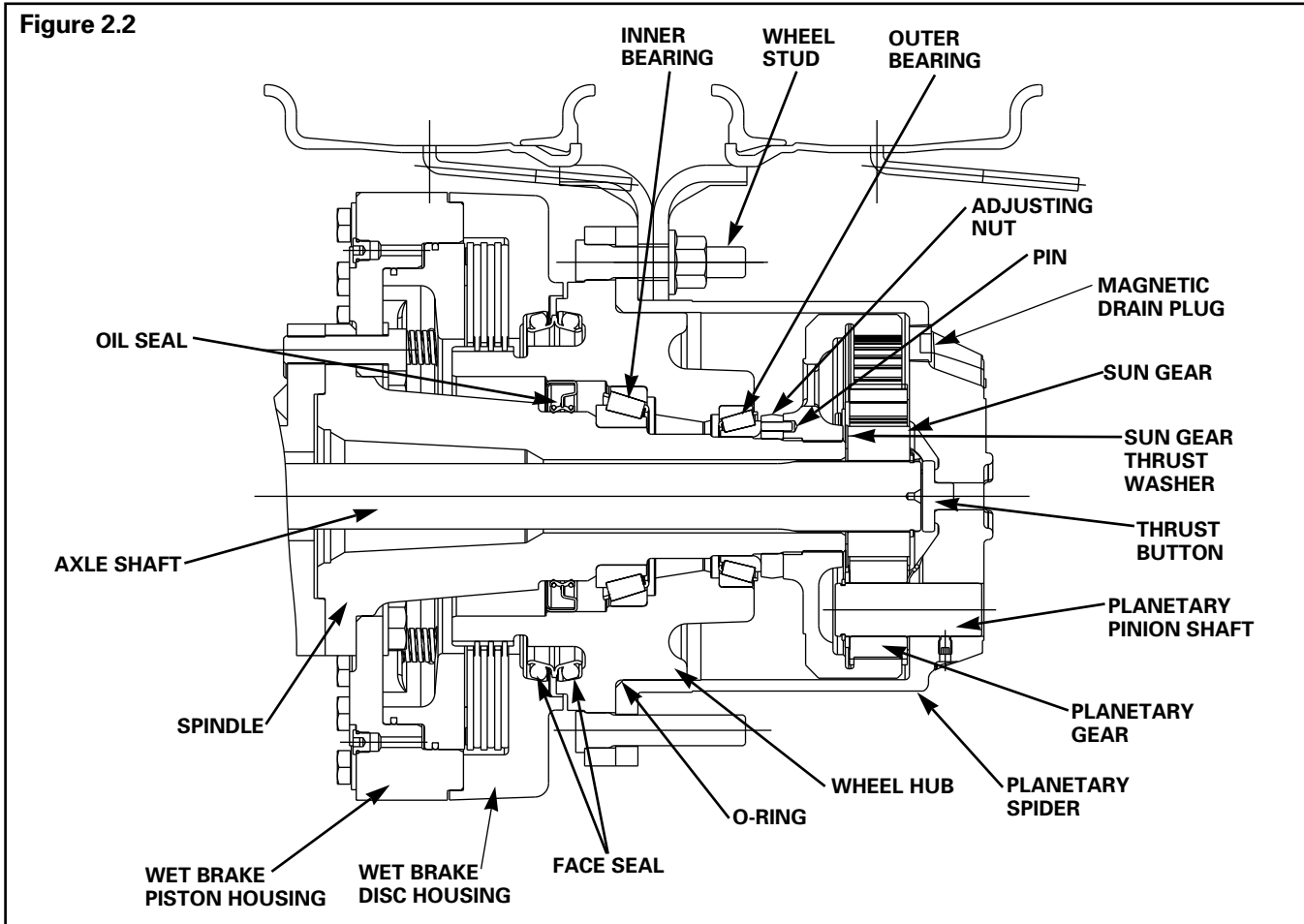

Wheel End with Outer Bearing on Spindle Journal

The W3H – 360 mm Dura-Disc wet disc brake is a hydraulically actuated friction brake. **Figure 2.2** shows the wet disc brake installed on the PRC 425 axle, which has a wheel end with the outer bearing installed on the spindle journal.

Three friction discs and three stationary discs are used in the wet disc brake for this type of wheel end.

- Friction discs rotate with the wheel hub.
- Stationary discs are locked to the brake housing with dowel pins.

The W3H – 360 mm wet disc brake uses a two-piece housing. The outer brake housing contains the discs, while the inner brake housing contains the piston and the piston seals.

Cooling Systems

⚠ CAUTION

The operating temperature of the coolant must never reach or exceed 250°F (120°C). If the operating temperature of the coolant reaches or exceeds 250°F (120°C), the internal components of the brake will be damaged. A forced cooling system may be required to assure that the coolant temperature remains below 250°F (120°C).

A forced cooling system is used. The forced cooling system removes more heat from the discs than a sump cooling system. An external pump moves hydraulic fluid from a reservoir to the brake housing and back to the reservoir.

Hub seals on forced cooling systems separate the brake's coolant from the lubricant in the planetary wheel end.

How to Identify the Brake Model

A tag on the planetary axle housing identifies the brake model. **Figure 2.3.**

You can also identify the brake assembly from the axle's Bill of Material. The 360 mm (14.17 inch) wet disc brake has slots and dowel pins that lock the stationary discs to the brake housing.

Refer to Maintenance Manual 4L, Wet Disc Brakes/W3H, W4H, W5H and W4M (Spring Applied Hydraulic Release), for information on a W3H wet disc brake with splines on the outside diameter of the stationary discs.

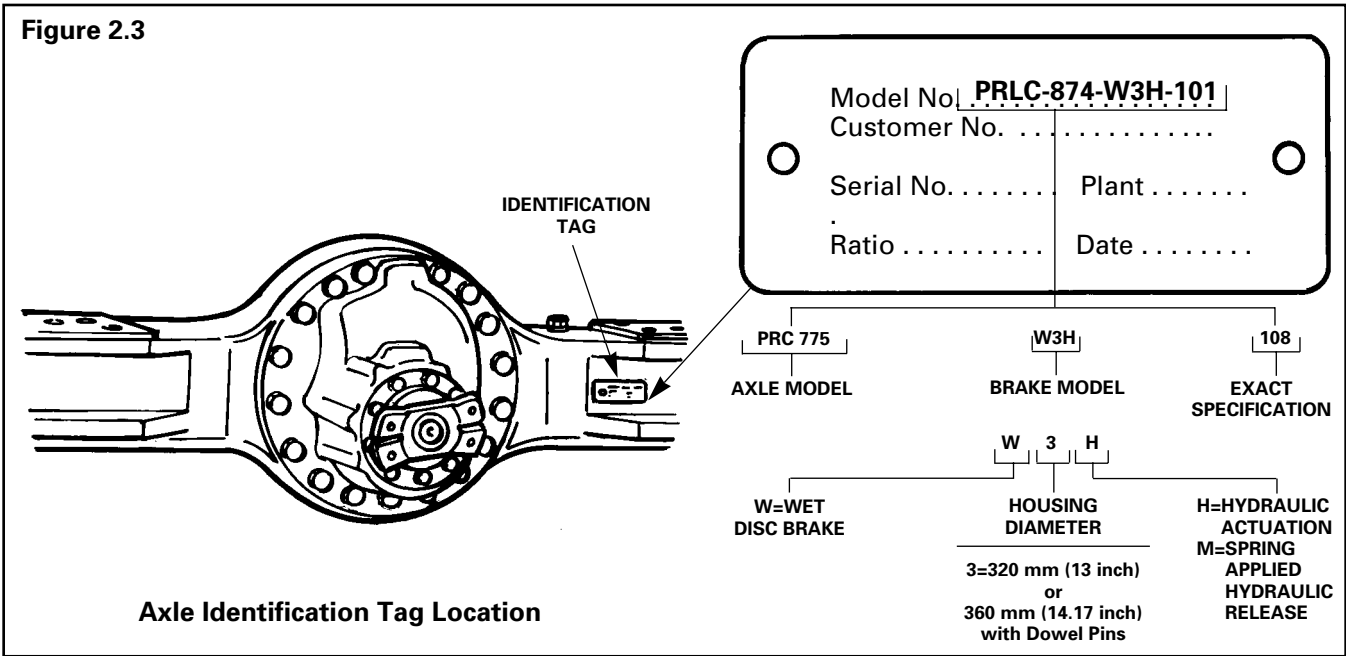

Section 3

Disassembly

WARNING

To prevent serious eye injury, always wear safe eye protection when you perform vehicle maintenance or service.

Removal

Wet Disc Brake

WARNING

Allow the brakes to cool to ambient temperature (cool to the touch) before draining fluid. Wear protective gloves. Personal injury can result.

Use only the type of fluid specified by the equipment manufacturer. Do not use or mix different types of fluid. An incorrect fluid can damage the rubber parts of the assemblies, which could cause loss of braking and serious personal injury.

Do not reuse hydraulic fluid or coolant. Used fluid may be contaminated and can cause incorrect operation, which can result in serious personal injury and damage to components.

Remove the wet disc brake assembly from the typical wheel ends as described below.

Drain Fluids from Wheel Ends

Disassembly of the wet disc brake is required to replace a leaky seal or worn brake disc pack. Use the following procedure:

WARNING

Block the wheels to prevent the vehicle from moving. Support the vehicle with safety stands. Do not work under a vehicle that is supported only by jacks. Jacks can slip or fall over. Serious personal injury can result.

1. Make sure the vehicle is on a level surface.
2. Place blocks under the wheels not being serviced to keep the vehicle from moving.
3. Raise the vehicle so that the wheels of the axle to be serviced are off the ground. Support the vehicle with safety stands. Refer to the vehicle manufacturer's maintenance manual for instructions on raising the vehicle.
4. Remove the wheel nuts and dual tire/rim assemblies from both wheel ends.
5. Rotate the wheel ends so the magnetic drain plug in the planetary spider is at the bottom.

WARNING

Allow the brakes to cool to ambient temperature (cool to the touch) before draining fluid. Wear protective gloves. Personal injury can result.

6. Place a suitable container under the wheel end, remove the magnetic drain/fill plug from the spider, and drain the lubricant. Dispose of the lubricant according to state and/or federal (EPA) recommendations.
7. If necessary, remove the magnetic drain plug from the bottom of the axle housing. Drain and dispose of the lubricant from the carrier center section.
8. If equipped with coolant shutoff valves, close the shutoff valves to prevent draining the brake lines and to make sure coolant does not flow into the brake housing during disassembly. Remove the forced coolant inlet and outlet lines from the brake piston housing assembly. Cap the lines to prevent possible contamination of the coolant.

Section 3 Disassembly

9. Place a suitable container under the brake piston housing to catch the drained fluid.

! CAUTION

To properly adjust brakes, remove or install the bottom adjuster screw and jam nut as outlined below. Improperly adjusted brakes can lead to uneven brake disc wear and accelerate brake disc wearout.

10. Matchmark the bottom adjuster screw position to the piston housing. The bottom adjuster screw must be repositioned to the same depth when reinstalled in order to ensure correct brake adjustment. **Figure 3.1.**

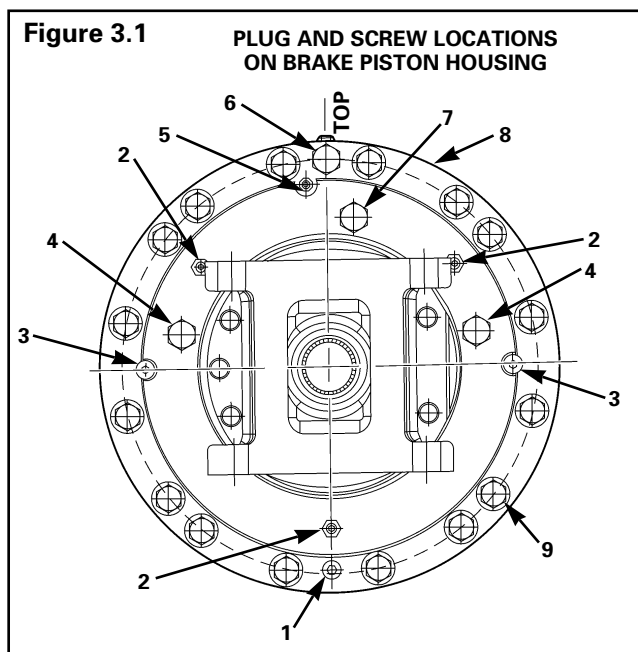

1. Plug, Magnetic Drain (1)
2. Adjuster Screw with Jam Nut (3)
3. Plug, Actuation Fluid Inlet (2)
4. Plug, Forced Cooling Outlet (2)
5. Screw, Actuation Fluid Bleeder (1)
6. Plug, Forced Cooling Inlet (1)
7. Plug, Air Evacuation (1)
8. Housing, Brake Piston (1)
9. Capscrew, Brake Piston Housing to Disc Housing (16)

11. With the adjuster screw matchmarked to the piston housing, place a suitable wrench on the bottom adjuster screw to keep it from rotating. While holding this wrench, use a second wrench to loosen the jam nut. The adjuster screw must not turn while the jam nut is being loosened.
12. Remove only the bottom adjuster screw to permit draining of the coolant from the brake housing. Do not remove the other two adjuster screws. Remove the bottom adjuster screw from the housing as follows:
 - A. Rotate the screw COUNTERCLOCKWISE and count the number of turns required to remove it.
 - B. Record this number.
13. When you have removed the adjuster screw, remove the recessed Allen-head drain plug from the brake housing. Allow the coolant to drain into the container.
14. Dispose of the used fluid in an environmentally responsible manner, according to state and/or federal (EPA) recommendations.
15. Install the bottom adjuster screw with the same number of turns and lined up with the matchmark on the piston housing to bring the brake to the original adjustment position.

Section 3 Disassembly

Cross Section – Wheel End with Outer Bearing on Ring Gear Hub Journal (PRC 775 shown as example)

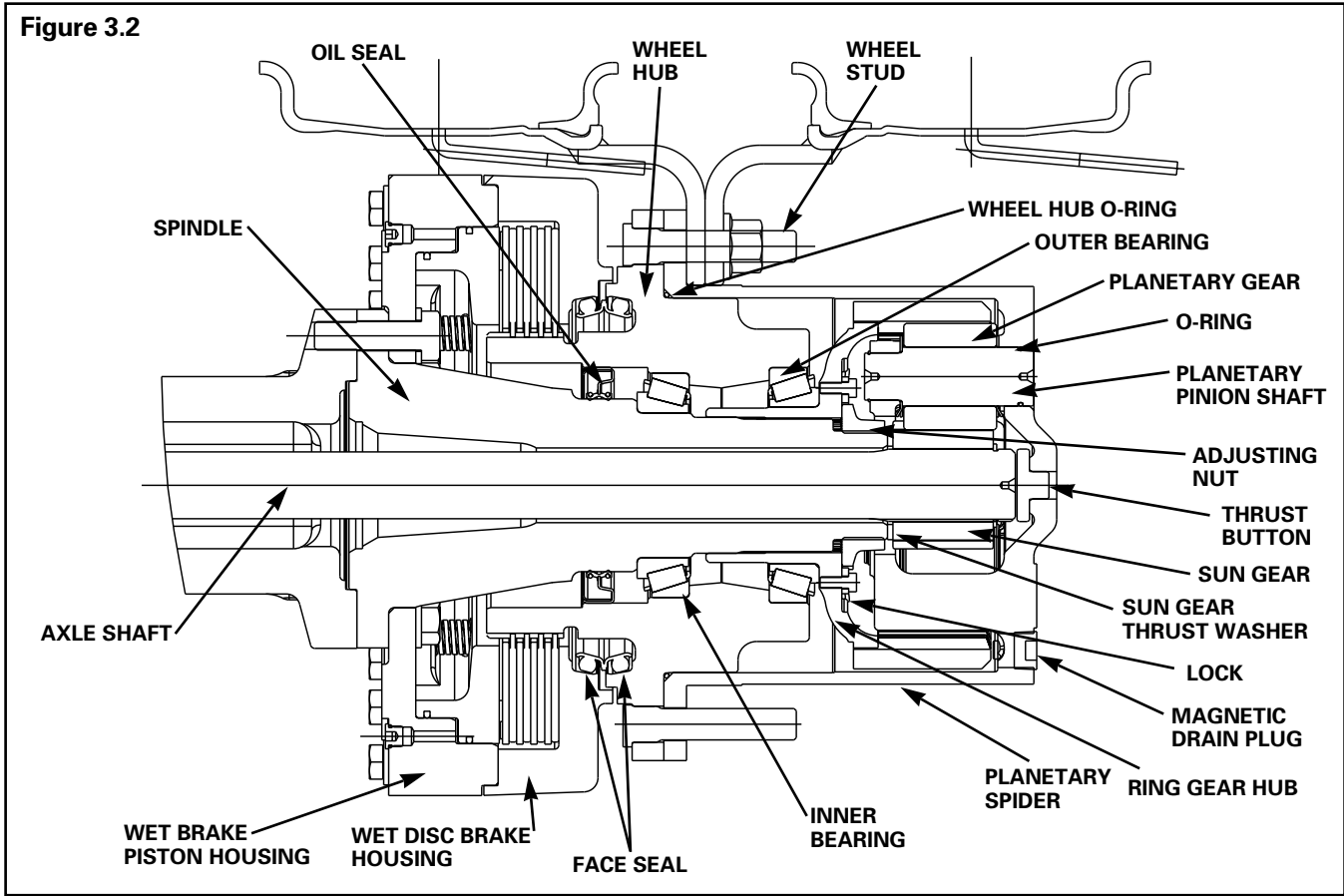

Wheel End with Outer Bearing on Ring Gear Hub Journal

⚠ WARNING

Support the planetary spider with a lifting strap before you remove the planetary spider from the wheel hub. A planetary spider that is not supported correctly can fall. Serious personal injury and damage to components can result.

1. With a lifting device, remove the planetary spider assembly from the wheel hub and set it on a workbench. See **Figure 3.2**.
2. If the planetary ring gear did not remain with the planetary spider assembly during the assembly's removal, remove the ring gear from the planetary ring gear hub.

⚠ WARNING

Observe all warnings and cautions provided by the press manufacturer to avoid damage to components and serious personal injury.

Use a brass or leather mallet for assembly and disassembly procedures. Do not hit steel parts with a steel hammer. Pieces of a part can break off and cause serious personal injury.

⚠ CAUTION

To avoid damage to the pinion shaft, provide a soft cushioned area to receive the pinion shaft when it is removed from the spider.

If it is necessary to service the planetary spider assembly, refer to Maintenance Manual 9K.

3. Remove the axle shaft, planetary sun gear and snap ring assembly.

Section 3 Disassembly

NOTE: The sun gear thrust washer may come out with the axle shaft and sun gear assembly.

4. Remove the sun gear thrust washer from the end of the spindle.
5. Remove the two lock plate capscrews. Remove the lock plate from the planetary ring gear hub.
6. Matchmark the position of the wheel bearing adjusting nut to the ring gear hub and spindle. Remove the wheel bearing adjusting nut.
7. Remove the planetary ring gear hub. The outer wheel bearing cone will remain on the ring gear hub. If it is damaged, remove it from the hub.
8. Remove the wheel hub with brake driver splines from friction discs. The hub oil seal and inner bearing assembly will remain in the hub.



CAUTION

One-half of the duo-cone face seal comes off with the hub. The other half will remain in the brake disc housing. Do not set the hub down onto the face seal. Damage to the face seal can result.

NOTE: Wrap and label the face seal halves separately. Store them in a safe place to prevent damage and reassemble them later in the same positions.

9. Remove the face seal half from the hub assembly.
10. Remove the rest of face seal from the brake housing assembly.



CAUTION

Do not damage the hub oil seal bore surface in the wheel hub. Damage to this surface will result in oil leakage after assembly.

NOTE: If it is necessary to replace the hub oil seal and bearings, refer to Maintenance Manual 9K.

11. Refer to Brake Piston Housing and Wheel Spindle for disassembly of brake disc housing assembly.

Section 3 Disassembly

Cross Section – Wheel End with Outer Bearing on Spindle Journal (PRC 425 shown as example)

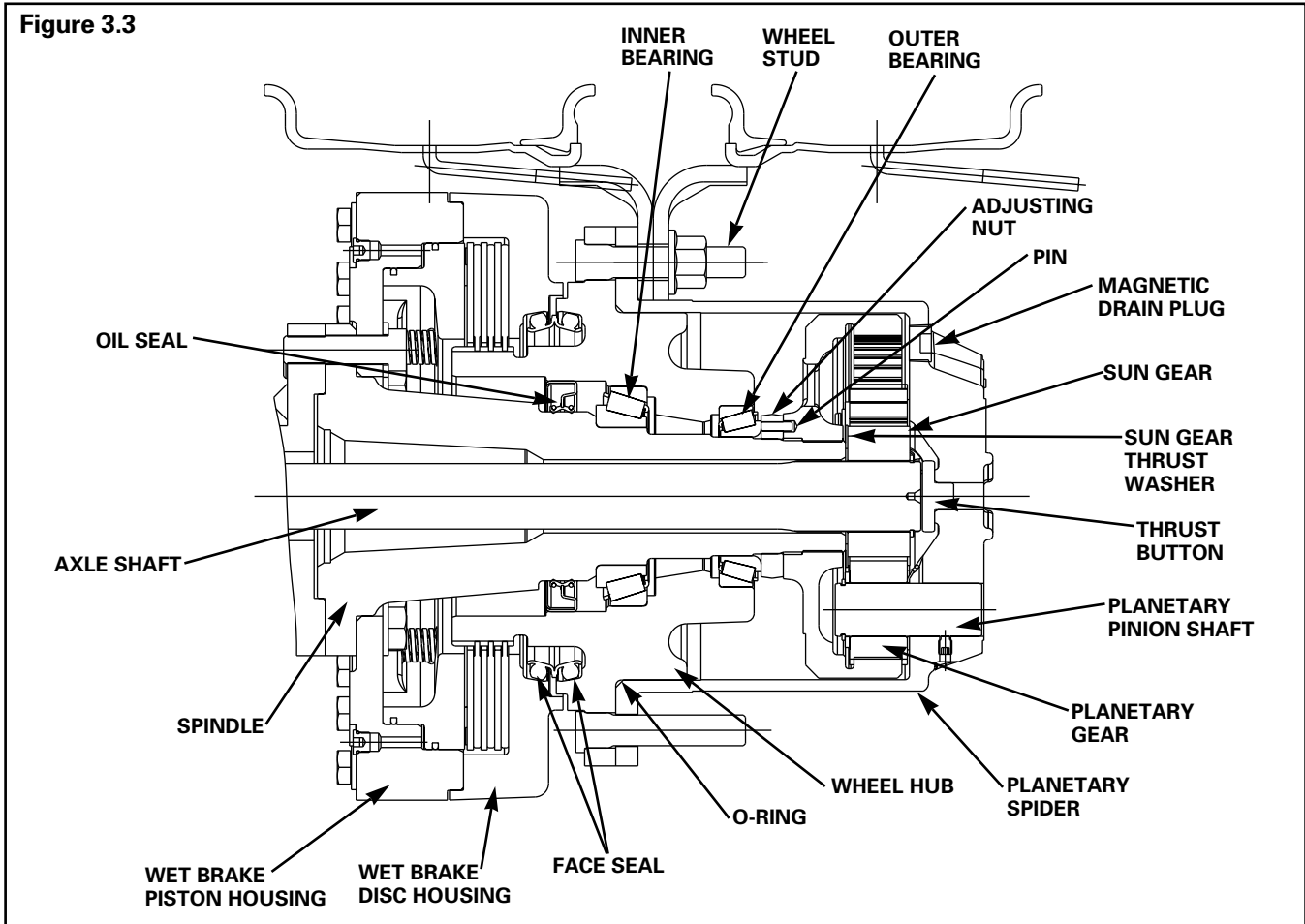

Wheel End with Outer Bearing on Spindle Journal

! WARNING

Support the planetary spider with a lifting strap before you remove the planetary spider from the wheel hub. A planetary spider that is not supported correctly can fall. Serious personal injury and damage to components can result.

1. With a lifting device, remove the planetary spider from the wheel hub. Set it on a workbench. See Figure 3.3.

! WARNING

Observe all warnings and cautions provided by the press manufacturer to avoid damage to components and serious personal injury.

Use a brass or leather mallet for assembly and disassembly procedures. Do not hit steel parts with a steel hammer. Pieces of a part can break off and cause serious personal injury.

! CAUTION

To avoid damage to the pinion shaft, provide a soft cushioned area to receive the pinion shaft if it is removed from the spider.

2. If it is necessary to service the planetary spider assembly, refer to Maintenance Manual 9K.

Section 3 Disassembly

NOTE: The sun gear thrust washer may come out with the axle shaft and sun gear assembly.

3. Remove the axle shaft, planetary sun gear and snap ring assembly.
4. If necessary, remove the snap ring from the axle shaft to allow for the removal of the sun gear and sun gear thrust washer.
5. Remove the planetary ring gear.
6. Matchmark the position of the wheel bearing adjusting nut to the spindle. Remove the wheel bearing adjusting nut.

CAUTION

The outer bearing cone will be loose as you pass it over the end of the spindle. Hold the cone securely to avoid dropping it and damaging the cone.

7. Remove the outer bearing cone and wheel hub assembly with brake driver splines from the friction discs. The wheel bearings and oil seal will come off with the wheel hub.

CAUTION

One-half of the duo-cone face seal comes off with the hub. The other half will remain in the brake disc housing. Do not set the hub down onto the face seal. Damage to the face seal can result.

NOTE: Wrap and label the face seal halves separately. Store them in a safe place to prevent damage and reassemble them later in the same positions.

8. Remove the face seal half from the hub assembly.
9. Remove the rest of the face seal from the brake housing assembly.

CAUTION

Do not damage the hub oil seal bore surface in the wheel hub. Damage to this surface will result in oil leakage after assembly.

NOTE: If it is necessary to replace the hub oil seal and bearing, refer to Maintenance Manual 9K.

Brake Disc Housing Assembly – Wheel End

WARNING

When you remove the 16 capscrews and washers from the perimeter of the brake piston housing, the brake disc housing can separate from the piston housing. Support the brake housing assembly with a lifting strap before you install the assembly onto the piston housing assembly. The discs in the brake housing assembly are loose and can fall. Serious personal injury and damage to components can result.

Disassemble the brake disc housing assembly from the wheel end as follows:

NOTE: Store the face seal with the O-ring in a safe, clean package to prevent damage.

1. If not previously removed, carefully remove, wrap and label the duo-cone face seal with O-ring from the outboard face of the brake disc housing and store in a safe place to prevent damage.

WARNING

Use a brass or leather mallet for assembly and disassembly procedures. Do not hit steel parts with a steel hammer. Pieces of a part can break off and cause serious personal injury.

2. Loosen the sixteen M16 x 1.5 threaded capscrews on the back of the piston housing. **Figure 3.1.** Hit threaded capscrew heads with a mallet to separate wet disc brake housing.
3. Remove all but two capscrews at the eleven o'clock and one o'clock positions.

Section 3

Disassembly

WARNING

Support the brake disc housing with a lifting strap before you remove the capscrews. A brake disc housing that is not supported correctly can fall. Serious personal injury and damage to components can result.

CAUTION

To avoid damaging the spindle seal journal, a protective pad (such as a clean, folded shop cloth) should be placed on the spindle seal journal before the brake disc housing is removed.

4. With the brake disc housing correctly supported by a lifting strap, remove the remaining perimeter capscrews holding the disc housing to the piston housing.

CAUTION

The friction discs and stationary discs are loose inside the brake housing assembly. Reach through the center of the brake housing and keep the discs from falling on the floor. A damaged disc cannot be reused.

5. Carefully remove the disc housing from the piston housing, making sure the discs do not fall out of the housing. A damaged disc cannot be reused. Place the disc housing open end up on the workbench.

CAUTION

Do not mix discs and their rubbing surfaces, because this can result in uneven brake disc wear after parts are reassembled. Component damage can result.

NOTE: Stack the stationary discs and friction discs separately outside the brake housing. Do not mix up the mating surfaces while inspecting and measuring the thickness. Component damage can result.

6. Mark the friction discs at the inner diameter splines and the stationary discs on the dowel tabs. Remove only the stationary discs and friction discs from the brake disc housing as follows.

- A. Start by marking the top stationary disc as Disc 1 on the left top tang that engages the dowel pin. Remove the stationary disc, flip it over and place it on a clean towel.
- B. Mark the first friction disc at the inner diameter spline as Disc 1, remove it, flip it over, and place it on top of the first stationary disc.
- C. Mark the second stationary disc as Disc 2, remove it, flip it over, and place it on top of the friction disc.
- D. Continue marking, removing, flipping, and stacking until all discs are removed from the brake housing and stacked in the same order as removed.

Brake Piston Housing Assembly

Disassemble the brake piston housing assembly as follows:

1. Remove the four shoulder bolts with washers and springs from the piston and housing assembly. Remove the washers and springs from the four shoulder bolts.

CAUTION

To avoid damaging the spindle seal journal, a protective pad (such as a clean, folded shop cloth) should be placed on the spindle seal journal before the piston and piston housing are removed.

2. Remove the piston by using one of the following methods:
 - Apply low air pressure to the back of the piston housing. Do not exceed 20 psi (1.38 bar or 138 kPa).
 - Turn the three brake adjuster screws **CLOCKWISE** and evenly until the piston is pushed out.
3. Place the piston on the workbench.

Section 3 Disassembly

⚠ CAUTION

Be careful to avoid scratching the piston seal grooves while removing the "D" seals, since this can result in actuation fluid leakage past the seals.

4. Carefully remove the "D" seals from the grooves in the piston and discard. "D" seals are not reusable and must be replaced with new seals.

Brake Piston Housing and Wheel Spindle

⚠ WARNING

Removal of the thirteen 20 mm capscrews from the inside of the piston housing allows the spindle and piston housing to separate. Support the piston housing with a lifting strap before you remove the capscrews. A piston housing that is not supported correctly can fall. Serious personal injury and damage to components can result.

1. To prevent the spindle and brake piston housing from falling after all the mounting capscrews are removed, perform the following procedures:
 - A. Use a lifting strap to support the piston housing and the spindle before disassembly.
 - B. Remove only two of the 13 capscrews holding the piston housing and spindle to the axle housing, one from the eleven o'clock position and one from the one o'clock position.
 - C. Replace the capscrews with temporary M20-2.5 threaded support studs 4 inches (102 mm) long. **Figure 3.3.**

Figure 3.3

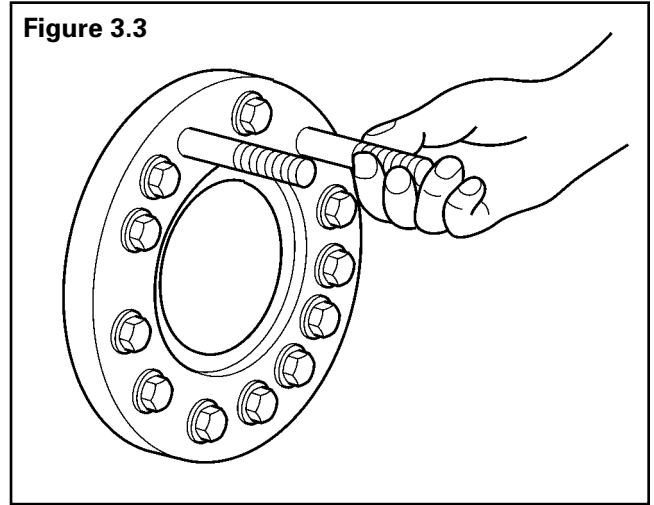

2. With the two support studs in place, remove the remaining 11 capscrews and washers that secure the piston housing and spindle to the axle housing.

⚠ CAUTION

To avoid damaging the spindle seal journal, a protective pad (such as a clean, folded shop cloth) should be placed on the spindle seal journal before the piston housing is removed. Be careful not to bump the spindle seal journal while removing the piston housing, since this can damage the seal journal. A spindle with a damaged seal journal will leak and must be replaced.

3. With the piston housing held by the lifting strap, remove the piston housing from the spindle by sliding it off of the support studs. Place the piston housing open end up on the workbench.
4. If necessary, to remove the spindle, support the spindle with a lifting strap.
5. Remove the spindle from the axle housing by sliding it off of the support studs.

⚠ WARNING

Use a brass or leather mallet for assembly and disassembly procedures. Do not hit steel parts with a steel hammer. Pieces of a part can break off and cause serious personal injury.

6. If required, tap the spindle lightly to loosen the pilot fit and overcome adhesion from the cured gasket material in the flange joint. Place the spindle on the workbench.

Section 4 Inspection

⚠ WARNING

To prevent serious eye injury, always wear safe eye protection when you perform vehicle maintenance or service.

Inspection

Inspect removed components as follows:

1. Inspect brake piston bores in the housing for wear or rough spots. Polish out roughness with fine crocus cloth. Clean housing to remove metal particles.
2. Inspect "D" seal grooves in the piston for rough spots. Polish out roughness with fine crocus cloth. Clean the piston to remove metal particles.

⚠ WARNING

Replace all the brake discs at one time to avoid uneven brake disc wear. Uneven brake disc wear can result in component damage and serious personal injury.

Keep used brake discs in the correct order with mating surfaces together. Installing the discs in an incorrect order can result in component damage and serious personal injury.

3. Inspect stationary discs and friction discs for flatness and wear. Measure the thickness of the discs. Overall thickness should not be less than that shown in **Table 1**. Replace the entire disc pack if one disc needs replacing.

Table 1. Minimum Brake Disc Thickness

Disc Type	Part Number	Minimum Thickness
Friction	A-3281-Z-1196	0.192 Inch (4.87 mm)
Stationary	3281-F-1203	0.167 Inch (4.25 mm)

4. Inspect brake piston return springs for damage and replace, if required.
5. Inspect fastener and plug bores for thread damage in the piston and disc housings. Use the appropriate taps lubricated with light oil to remove minor thread damage.

6. Inspect fasteners and plugs for obvious signs of damage, such as distorted (brinelled) threads or damaged hex corners. Replace any fastener or plug with thread damage that cannot be repaired by running it through the appropriate die.
7. Inspect O-rings on plugs and replace any damaged O-ring.
8. Inspect duo-cone face seals and O-rings as follows:

⚠ CAUTION

Install face seal halves in the same positions where they were located prior to disassembly. Mixing up face seal halves can cause component damage.

- Look for obvious signs of damage. Replace any damaged face seal or O-ring. Replace any O-ring that is stuck to the seal or brake housing or any that has taken a "set" or cannot be pulled and "snapped" into position on the seal ring retaining lip.
- Duo-cone formed face seals are more flexible than cast ring seals and, as a result, produce a wear pattern different than cast ring designs. Typically, formed seals wear in an axial rather than radial direction, as depicted below, due to their increased flexibility. **Figure 4.1**.

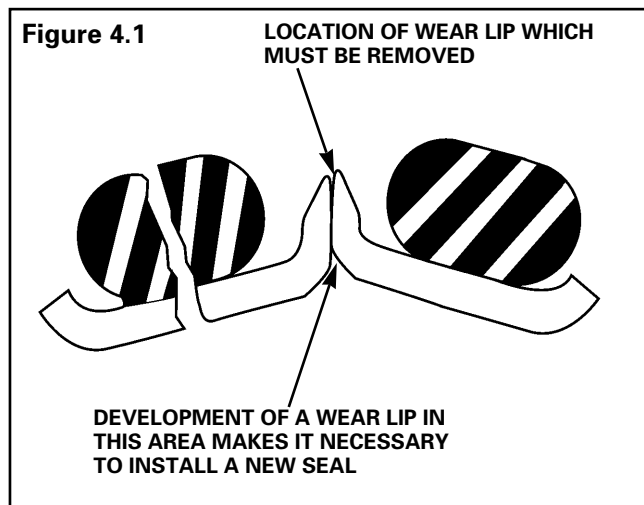

Section 4 Inspection

- The total thickness of the flange is the usable wear material on the formed seal rings, and good seal performance can generally be expected until the flange is completely worn away. Estimate the remaining service life of the seal ring by measuring the ring flange thickness and comparing that measurement to those listed in **Table 2**. The minimum flange thickness required for seal ring usability is 1.27 mm (0.050 in.).
- With formed seal rings, the measured parameter used to check the remaining seal ring life is the flange thickness at the outer edge. Measure carefully, since the shoulder is only 1.52 mm (0.060 in.) from the edge of the flange.

Table 2. Formed Seal Wear Chart

Flange Thickness mm (inch)	Seal Wear % Worn
1.91 (0.075)	0
1.59 (0.062)	25
1.27 (0.050)	50
0.95 (0.038)*	75
0.64 (0.025)*	100
0.32 (0.012)*	125
0.00 (0.000)*	150

*Seal ring not usable. Replace seal ring.

Section 5

Prepare Parts for Assembly

WARNING

To prevent serious eye injury, always wear safe eye protection when you perform vehicle maintenance or service.

Clean Components Prior to Assembly

WARNING

To avoid personal injury when cleaning parts, work in a well-ventilated area, wear protective clothing (face shield or safety glasses and protective gloves) and follow chemical manufacturer's recommendations for safe usage.

Solvent cleaners can be flammable, poisonous and cause burns. Examples of solvent cleaners are carbon tetrachloride, emulsion-type cleaners and petroleum-base cleaners. To avoid serious personal injury when you use solvent cleaners, you must carefully follow the manufacturer's instructions and these procedures:

- Wear safe eye protection.
- Wear clothing that protects your skin.
- Work in a well-ventilated area.
- Do not use gasoline or solvents that contain gasoline. Gasoline can explode.
- You must use hot solution tanks or alkaline solutions correctly. Carefully follow the manufacturer's instructions.

CAUTION

Use only solvent cleaners to clean ground or polished metal parts. Hot solution tanks or water and alkaline solutions will damage these parts. Isopropyl alcohol can be used for this purpose.

If required, use a sharp knife to remove gasket material from parts. Be careful not to damage the ground or polished surfaces.

CAUTION

Keep used brake discs in the correct order with mating surfaces together. Install discs and face seal halves in the same positions where they were located prior to disassembly. Mixed up face seals and discs can cause component damage.

WARNING

Wear a faceplate or safety glasses when using compressed air. Do not exceed 40 psi (276 kPa). Serious personal injury can result.

1. Clean all metal components in pure isopropyl alcohol or commercial parts cleaner. Make sure all sealing surfaces are free of sealant or gasket material. Use a soft-bristled brush on these surfaces, if required. Blow dry with compressed air.

CAUTION

Clean friction discs in fresh brake coolant. Wipe dry with clean, lint-free cloths or blow dry with compressed air. Do not use solvent. Solvent can weaken the disc material and damage to components can result.

2. Clean friction discs in fresh brake coolant only. Wipe dry with clean, lint-free cloths or blow dry with compressed air.
3. Inspect the duo-cone face seal tapered ramps in the wheel hub and brake disc housing that contact the O-rings. To avoid seal damage, these areas must be free of oil, grease, dirt, and other contamination before the seals with O-rings are installed. Clean as necessary.
4. Clean the brake disc housings and the metal face seals for the O-rings using isopropyl alcohol and a lint-free wipe. Dry with a clean wipe or compressed air.
5. Using a lint-free wipe, clean the O-rings in non-petroleum-based solvent. Dry with a clean wipe or compressed air.
6. Inspect cleaned components thoroughly to make sure any contaminants are removed.
7. Scrape all bolted joint surfaces to remove sealant prior to reassembly.

WARNING

To prevent serious eye injury, always wear safe eye protection when you perform vehicle maintenance or service.

Installation

Wheel Spindle

WARNING

Solvent cleaners can be flammable, poisonous and cause burns. Examples of solvent cleaners are carbon tetrachloride, emulsion-type cleaners and petroleum-base cleaners. To avoid serious personal injury when you use solvent cleaners, you must carefully follow the manufacturer's instructions and these procedures:

- Wear safe eye protection.
 - Wear clothing that protects your skin.
 - Work in a well-ventilated area.
 - Do not use gasoline, or solvents that contain gasoline. Gasoline can explode.
 - You must use hot solution tanks or alkaline solutions correctly. Carefully follow the manufacturer's instructions.
1. Clean the face of the axle housing and both sides of the spindle flange with solvent to remove any remaining gasket material and blow dry.
 2. If previously removed, install two temporary studs (M20-2.5 threads, approximately four inches long) into the axle housing flange. Install the studs at the eleven o'clock and one o'clock positions. **Figure 6.1.**

Figure 6.1

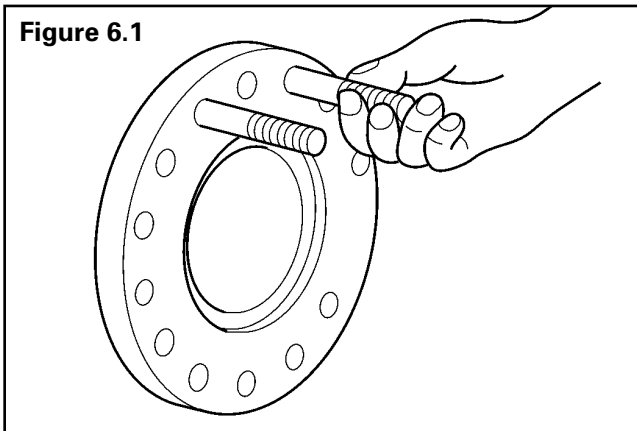

WARNING

When you apply some silicone gasket materials, small amounts of acid vapor are present. To prevent possible serious injury, the work area must be well ventilated. If the silicone gasket material gets into your eyes, flush them with water for 15 minutes. Have your eyes checked by a doctor as soon as possible.

3. Apply a 0.125 inch (3.18 mm) diameter continuous bead of silicone gasket material around the flange mounting face of either the axle housing or the spindle. Also apply the gasket material around the edge of all the fastener holes on that surface. **Figure 6.2.**

Figure 6.2

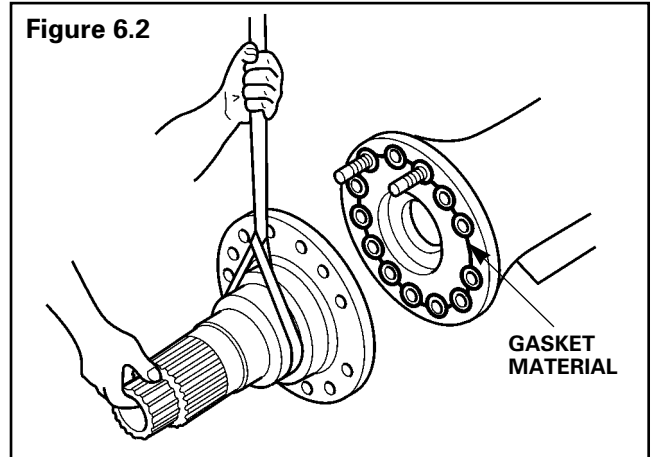

WARNING

Support the axle spindle with a lifting strap before you install the spindle onto the axle housing. A spindle that is not supported correctly can fall. Serious personal injury and damage to components can result.

4. Support the spindle with a lifting strap. Align the missing hole locations on the spindle and axle housing. Install the spindle onto the two support studs and against the axle housing. **Figure 6.2.**
5. Remove the lifting strap.

Section 6 Assembly

Brake Piston Housing

WARNING

When you apply some silicone gasket materials, small amounts of acid vapor are present. To prevent possible serious injury, the work area must be well ventilated. If the silicone gasket material gets into your eyes, flush them with water for 15 minutes. Have your eyes checked by a doctor as soon as possible.

1. Apply a 0.125 inch (3.18 mm) diameter continuous bead of silicone gasket material around the flange face of the spindle. Also apply a continuous bead of the gasket material around the edge of all the fastener holes on that surface.



CAUTION

Place a protective pad, such as a clean, folded shop cloth, on the spindle seal journal before you install the piston housing to prevent damage to the seal journal.

WARNING

Support the piston housing with a lifting strap before you install the piston housing onto the spindle. A piston housing that is not supported correctly can fall. Serious personal injury and damage to components can result.

NOTE: The piston housing has TOP identified by a raised lug.

2. Support the piston housing with a lifting strap. Install the piston housing onto the two support studs and against the spindle.
3. Install the thirteen M20 x 2.5 thread capscrews and washers that secure the piston housing and spindle to the axle housing and tighten securely. Remove the lifting strap.
4. Remove the two temporary support studs and install the remaining two capscrews and washers. Tighten the capscrews in two stages:
 - A. Using an "X" torquing pattern, tighten to 150 lb-ft (203 N•m) initial torque. 
 - B. Using an "X" torquing pattern, tighten to 370-480 lb-ft (500-650 N•m) final torque. 

CAUTION

You must install the adjuster screw and jam nut into the piston housing when you assemble the brakes to ensure correct brake adjustment and avoid damage to components.

NOTE: Brakes with new disc packs require adjustment after the wheel end assembly is complete.

5. If the adjuster screws were used to push the piston out of the piston housing or if you replaced the brake disc pack, perform the following operations:

- A. Clean and install the three disc brake adjuster screws in the piston housing.
- B. Turn the adjuster screws in halfway.

NOTE: Do not install the jam nuts at this time.

- C. Proceed to Step 7.
6. Clean the previously removed bottom adjuster screw, and install the screw in the piston housing as follows:
 - A. Install the screw with the same number of turns and lined up with the matchmark on the piston housing to bring the brake to the original adjustment position.
 - B. Insert the bottom adjuster screw into the piston housing (**Figure 6.3**).
 - C. Slowly rotate it **CLOCKWISE** the same number or turns used for removal.

CAUTION

Hold the adjuster screw in place to ensure that the brakes are adjusted correctly. Do not allow the adjuster screw to turn. If the adjuster screw turns, damage to components can result.





- D. Apply silicone sealant to the interface between the base of the adjuster screw and the housing and install the jam nut lightly onto the screw. Do not allow the screw to turn.
- E. Using a suitable wrench to prevent movement of the screw, tighten the jam nut to 25-35 lb-ft (34-47 N•m). 

Figure 6.3 PLUG AND SCREW LOCATIONS ON BRAKE PISTON HOUSING

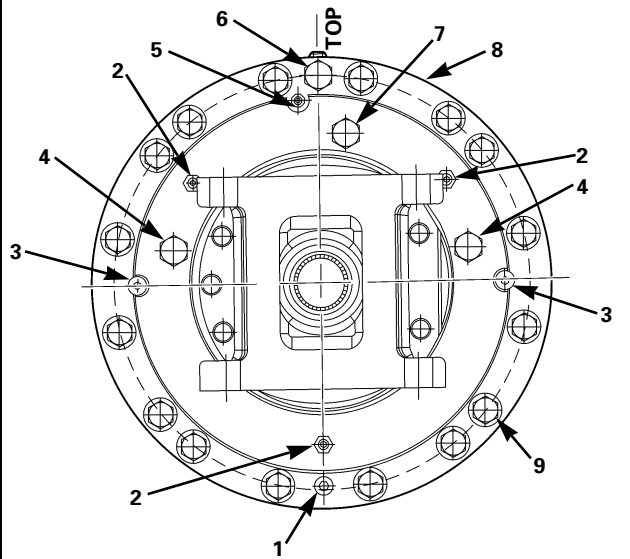

1. Plug, Magnetic Drain (1)
2. Adjuster Screw with Jam Nut (3)
3. Plug, Actuation Fluid Inlet (2)
4. Plug, Forced Cooling Outlet (2)
5. Screw, Actuation Fluid Bleeder (1)
6. Plug, Forced Cooling Inlet (1)
7. Plug, Air Evacuation (1)
8. Housing, Brake Piston (1)
9. Capscrew, Brake Piston Housing to Disc Housing (16)

7. If the 0.875-14 UNF forced cooling inlet, forced cooling outlet, and air evacuation O-ring plugs were previously removed from the piston housing, clean the plugs, install in the piston housing, and tighten to 60-75 lb-ft (81-102 N•m). 
8. If the 0.5625-18 UNF actuation fluid O-ring plugs in the 3 o'clock or 9 o'clock positions on the piston housing were previously removed, clean the plugs, install in the housing, and tighten to 25-35 lb-ft (34-47 N•m). 
9. If the recessed Allen head 3/8-18 NPTF magnetic drain plug at the 6 o'clock position was previously removed, clean the plug, apply silicone sealant, install in the housing, and tighten to 25-35 lb-ft (34-47 N•m). 
10. If the 0.4375-20 UNF bleeder screw between the 11 o'clock and 12 o'clock positions in the piston housing was previously removed, clean the screw and install in the housing.

Piston Assembly

1. Clean and inspect the piston for damage. Inspect the piston grooves to ensure no contaminants remain in the grooves.
2. Apply an oil lubricant to the "D" seals and assemble the "D" seals into the appropriate grooves in the piston.
3. Fabricate four M8 X 1.25 threaded assembly studs like the piston spring shoulder bolts, but without the heads.

NOTE: The piston slightly sticks out of the piston housing.

4. Install the four fabricated assembly studs into the piston return spring shoulder bolt holes in the piston housing.

CAUTION

Place a protective pad, such as a clean, folded shop cloth, on the spindle seal journal before you install the piston housing to prevent damage to the seal journal.

5. Apply an oil film coating on the piston housing bores. Use "C" clamps to assemble the piston over the assembly studs and push the piston into the piston housing until it bottoms out.
6. Remove and store the four assembly studs.
7. Install washers and springs on the four shoulder bolts.

WARNING

Take care when using Loctite® to avoid serious personal injury. Follow the manufacturer's instructions to prevent irritation to the eyes and skin. If Loctite gets into your eyes, flush them with water for 15 minutes. Have your eyes checked by a doctor as soon as possible.

8. Apply a small bead of Loctite 518 sealant to the four shoulder bolt threads and install the four shoulder bolts into the piston and piston housing. Tighten the four shoulder bolts to 22-30 lb-ft (30-40 N•m). 

Section 6 Assembly

Brake Disc Housing

WARNING

Replace all the brake discs at one time to avoid uneven brake disc wear. Uneven brake disc wear can result in component damage and serious personal injury.

Install used brake discs in the correct order with mating surfaces together. Installing the discs in an incorrect order can result in component damage and serious personal injury.

NOTE: The brake housing has TOP identified with a raised lug.

1. Clean and inspect the brake housing, stationary plates and dowels for damage.
- **If all of the friction discs and stationary discs can be reused:** Reinstall them into the cleaned brake disc housing by stacking the discs in the same order and wear surface orientation as prior to disassembly.
- **If all discs are being replaced:** Line up all the friction disc splines and grooves in a stack so that they can be assembled this way inside the brake housing.

WARNING

Support the brake housing assembly with a lifting strap before you install the assembly onto the piston housing assembly. The discs in the brake housing assembly are loose and can fall. Serious personal injury and damage to components can result.

CAUTION

Do not reuse a damaged friction disc or stationary disc. Damage to components can result.

Do not mix discs and their mating surfaces, which can result in uneven brake disc wear after parts are reassembled. Damage to components can result.

Do not lubricate brake discs prior to assembly. Lubricant can run onto the brake disc housing and mix with Loctite® sealant, which will cause the sealing joint to leak. Damage to components can result.

2. Place the brake housing on an assembly bench. If previously removed, assemble the eight dowel pins into the slots in the brake housing.

3. Place a friction disc inside the brake housing. Place a stationary disc into the brake housing while engaging all the dowels in the disc's slots.
4. Alternate in this manner (friction disc/stationary disc) until all discs are installed. Realign all the friction disc splines and grooves.

WARNING

Take care when using Loctite® to avoid serious personal injury. Follow the manufacturer's instructions to prevent irritation to the eyes and skin. If Loctite gets into your eyes, flush them with water for 15 minutes. Have your eyes checked by a doctor as soon as possible.

5. Apply a continuous, two millimeter diameter bead of Loctite® 518 sealant onto the mounting face of the brake housing. Sealant must be on the inner side (inboard) of the bolt holes to keep fluid from reaching bolts. See **Figure 6.4**.

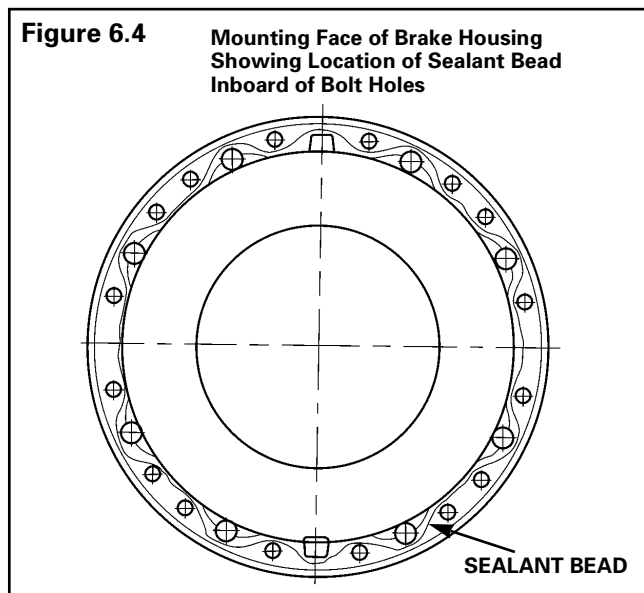



CAUTION

Place a protective pad, such as a clean, folded shop cloth, on the spindle seal journal before you install the disc housing assembly to prevent damage to the seal journal.

WARNING

The discs in the brake disc housing assembly are loose. The discs must be correctly supported when the assembly is raised to a vertical position and lifted for installation onto the piston housing assembly. A falling disc can result in disc damage and serious personal injury. A damaged disc cannot be reused.

6. Carefully lift the brake housing assembly (lug on TOP) and install it onto the piston housing that is already mounted on the axle.
7. Tighten sixteen M16 x 1.5 threaded capscrews in two stages:
 - A. Using an "X" tightening pattern, tighten to 150 lb-ft (203 N•m). 
 - B. Using an "X" tightening pattern, tighten to 200-258 lb-ft (270-350 N•m). 

Duo-Cone Face Seal into Brake Disc Housing and into Hub

CAUTION

Install face seal halves in the same positions where they were located prior to disassembly. Mixing up face seal halves can cause component damage.

The duo-cone face seal half with the O-ring must be installed in the brake disc housing and into the hub before the hub can be assembled to the housing. **Figure 6.5.** Install the duo-cone face seal in the brake disc housing and in the hub as

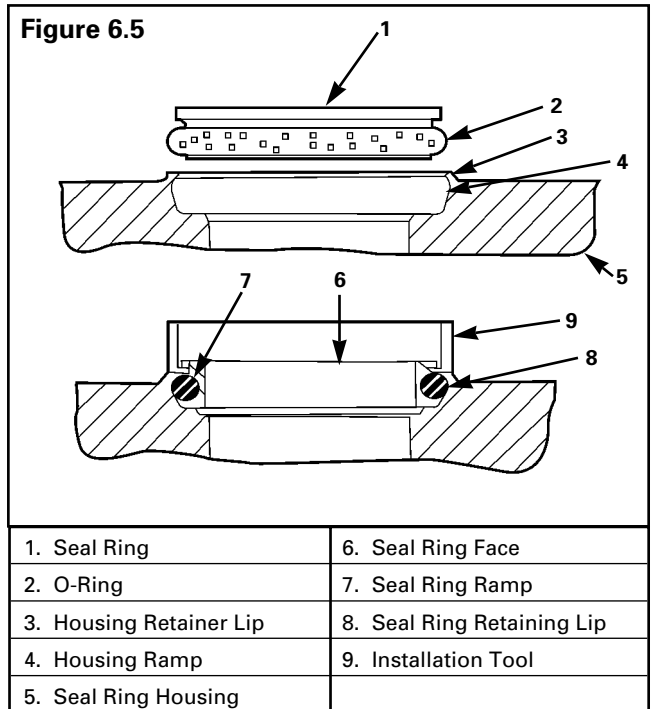

Section 6 Assembly

follows:

! WARNING

Solvent cleaners can be flammable, poisonous and cause burns. Examples of solvent cleaners are carbon tetrachloride, emulsion-type cleaners and petroleum-base cleaners. To avoid serious personal injury when you use solvent cleaners, you must carefully follow the manufacturer's instructions and these procedures:

- *Wear safe eye protection.*
- *Wear clothing that protects your skin.*
- *Work in a well-ventilated area.*
- *Do not use gasoline, or solvents that contain gasoline. Gasoline can explode.*
- *You must use hot solution tanks or alkaline solutions correctly. Carefully follow the manufacturer's instructions.*

! CAUTION

Check for solvent residue on all seating surfaces. Solvents that leave a residue on the O-ring, metal face seal or brake disc housing seal seating surface can cause the O-ring to roll into the seal, rather than slide. Damage to the seal can result.

1. Make sure the formed seal ring, O-ring and brake disc housing are clean and free of any oil or other contaminants. If required, use a solvent that evaporates quickly, leaves no residue, and is compatible with the O-rings.

! CAUTION

Install the O-ring into the seal ring and make sure it is flat. Do not twist the O-ring when installing onto the seal ring. A twisted O-ring will not seal correctly, allowing leakage of lubricant and pumping of debris past the ring. Damage to components can result.

2. Install the O-ring onto the formed seal ring so that it rests in the radius of the tail of the seal ring and is not twisted. Install the O-ring onto the seal ring as follows:

! CAUTION

Do not use Stanosol® or any other liquid that leaves an oily film and does not evaporate quickly, since this may result in incorrect seating of the O-ring in the housing, resulting in seal leakage.

- A. Wet the rubber O-ring with isopropyl alcohol and install it onto the formed seal ring so that it is seated at the bottom of the seal ring ramp and against the retaining lip. **Figure 6.6.**

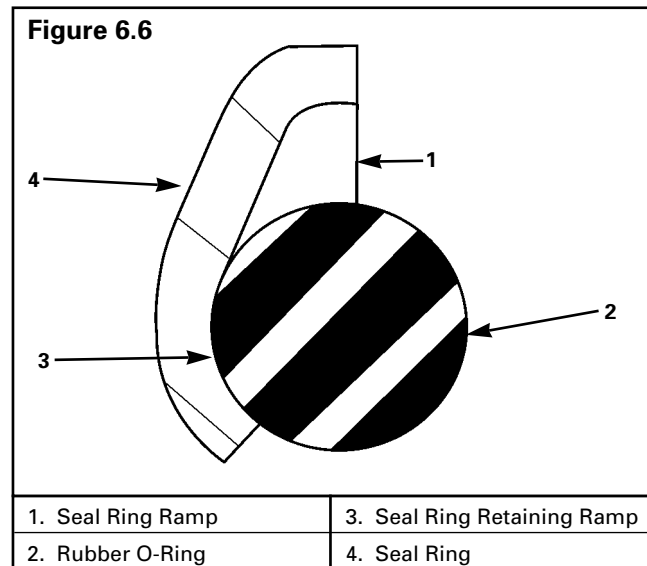

- B. Make sure the O-ring is not twisted by rapidly pulling it away from the seal ring and letting it snap back. Do this in a number of places until the seal is correctly seated. Be careful not to nick or cut the O-ring seal, as this will cause leaks. **Figure 6.7.**

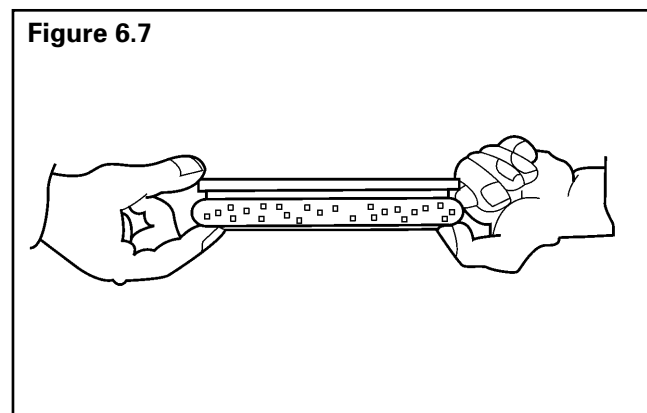

Section 6 Assembly

CAUTION

Do not use Stanosol® or any other liquid that leaves an oily film and does not evaporate quickly, since this may result in incorrect seating of the O-ring in the housing, resulting in seal leakage.

3. Coat the O-ring with isopropyl alcohol so that it slides easily past the retainer lip in the disc housing and installs correctly on the housing ramp (see **Figure 6.5**).
4. Place installation tool 1U6438 15° around the metal seal ring and O-ring. Installation tools are available from authorized Caterpillar® distributors.
5. Wipe the O-ring with a lint-free towel or clean foam brush saturated with isopropyl alcohol.
6. Shake excess lubricant from the assembly. Immediately install ("pop") the seal into the brake disc housing with a firm push of the installation tool. **Figure 6.8**.
7. Remove the installation tool.

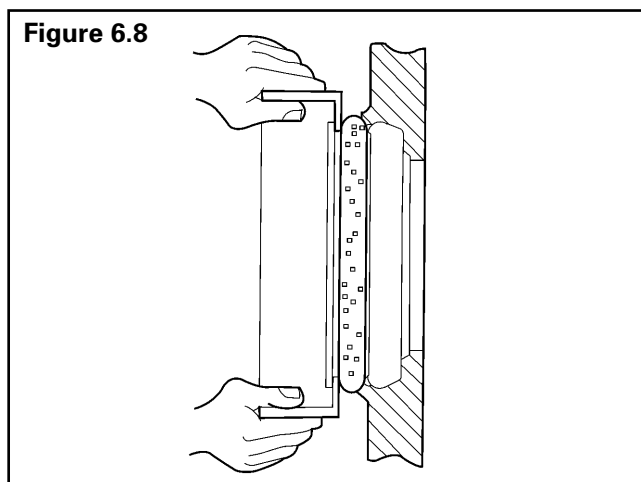

8. Follow the same procedure to install the other half of the face seal assembly onto the wheel hub. **Figure 6.9**.

Figure 6.9

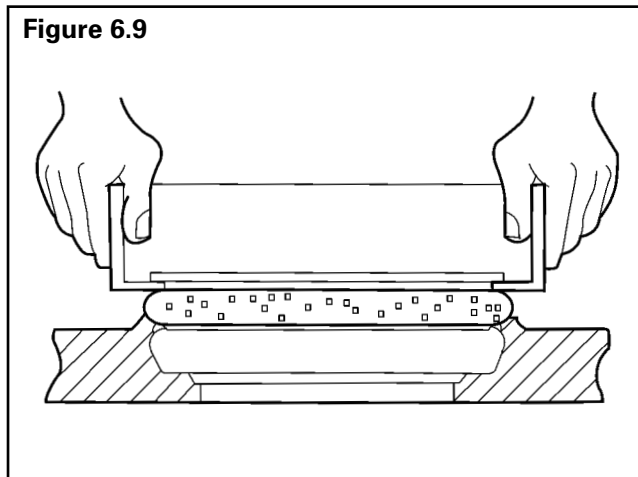

Check for Correct Installation of the Duo-Cone Seal

Check the disc brake housing and wheel hub for correct installation of the duo-cone face seal before the hub can be installed onto the housing.

1. Check assembled height variation (A) in at least four places, 90 degrees apart, using a caliper, toolmaker's rule, or other accurately calibrated measuring device. The difference in height around the ring must not be more than 0.5 mm (0.02 inch). **Figure 6.10**.

Figure 6.10

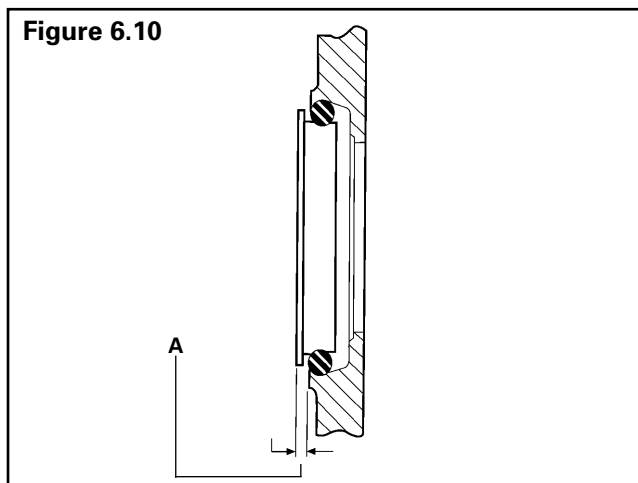

Section 6 Assembly

2. If required, adjust the seal standout height by using the following methods.

- **If the standout height cannot be brought into specification:** Remove the seal and repeat the installation procedure.

! CAUTION

Push or pull the O-ring and face seal only. Do not push or pull directly on the seal ring. This can cause component damage.

- A. Use the installation tool to push down on the O-ring and face seal.
- B. With your fingers, pull up uniformly on the O-ring and face seal.

! CAUTION

Apply isopropyl alcohol to the O-ring. Check the retaining lip of the seal seating area for burrs or fins, which can cause a seal to leak. Damage to components can result.

3. Apply isopropyl alcohol as a lubricant to the O-ring and place in the seating area. If installation does not appear smooth, flat and correct, remove the seal from the brake disc housing and repeat the process.

! CAUTION

To prevent slippage of the O-ring, allow sufficient evaporation time for the assembly lubricant before proceeding with further assembly. Damage to components can result.

4. Seat O-ring correctly. Once correctly in place, the O-ring must roll on ramp only. See **Figure 6.11** for examples of incorrect installation.

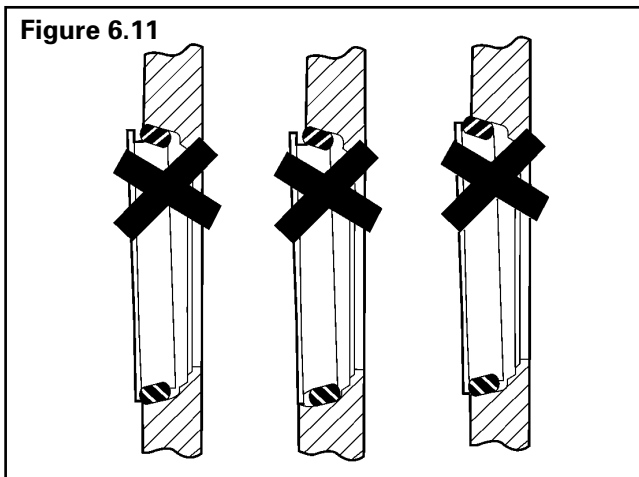

Wheel Hub to Brake Disc Housing

NOTE: Complete the assembly of the wheel hub to the brake housing. Before installing the wheel hub onto the brake disc housing, however, keep the following points in mind to ensure correct sealing between the faces of the duo-cone seals:

1. Check both sealing faces carefully to make sure they are clean and free of any dirt, debris, lint, and even human hair.

! CAUTION

Bring the housings together slowly. High impact can result in component damage. Remove protective pad from the spindle's seal journal.

2. Remove the protective pad from the spindle's seal journal.

- When installing the hub onto the spindle, both seal housings must be aligned correctly.
- Slowly bring the two housings together as the spindle adjustment nut is tightened.

Figure 6.12.

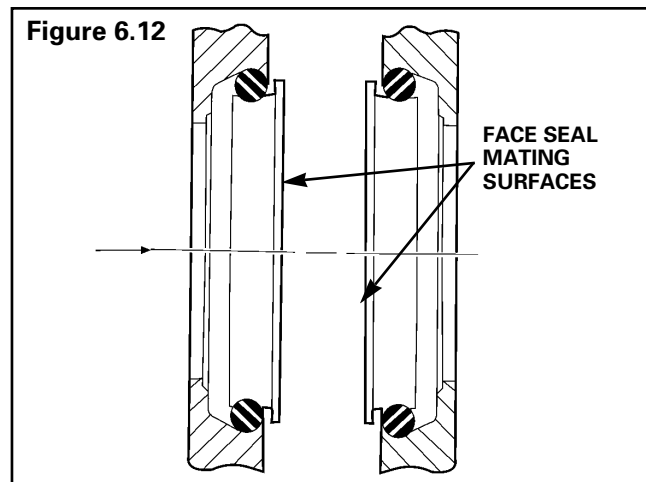

- **If the seals are not aligned correctly:** The seals will move. Any wobbling motion of the seals is an indication of incorrectly positioned (cocked) seals. Dirt can enter past the O-ring.
- Shown in **Figure 6.13**, the O-rings have slipped, instead of rolling on the left-hand side of the seal. Note how the top O-ring is to the right and the bottom O-ring is to the left. The same seals are also shown after the bottom half is rotated 90 degrees.
- **If the O-ring slips at any location,** it will twist, causing the formed seal rings to seat incorrectly (cock).

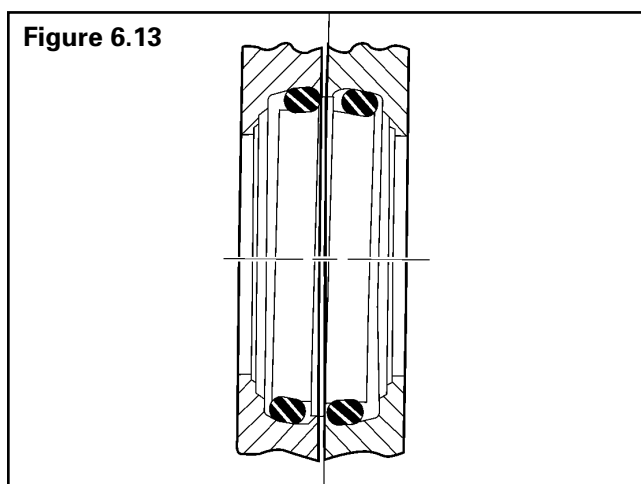

CAUTION

Do not apply lubricant to the O-ring. The O-ring can leak. Damage to components can result.

3. Apply a light coating of Dow Corning GN molybdenum assembly paste lubricant to the two mating surfaces of the face seal's steel rings only. Do not allow this lubricant to contact the O-ring. The O-ring can leak. **Figure 6.12.**

NOTE: If not previously removed, remove the protective cloth or pad from the spindle seal journal before installing the hub.

4. Install the hub with brake driver splines through the friction discs.
5. Install the outer bearing cone on the ring gear hub. Install the spindle nut on the spindle. Rotate the hub while tightening the nut as defined in wheel bearing adjustment procedure.

Adjustment

Wheel Bearing Preload – Wheel End with Outer Bearing on Ring Gear Hub Journal (PRC 775, for example)

NOTE: To adjust the wheel bearing preload, the bearings must be correctly seated and the rollers correctly aligned.

1. Install the wheel bearing adjusting nut. Tighten the nut to 400 lb-ft (542 N•m). **T**

WARNING

Use a brass or leather mallet for assembly and disassembly procedures. Do not hit steel parts with a steel hammer. Pieces of a part can break off and cause serious personal injury.

2. Rotate the hub in both directions. At the same time, tap the hub several times with a brass or plastic mallet.
3. Tighten the nut to 400 lb-ft (542 N•m) again. **T**
4. Back off the nut approximately 1/4 turn to relieve the preload produced in Step 3.
5. Tighten the nut to 200 lb-ft (271 N•m). **T**

NOTE: If you move the adjusting nut to align the lock plate mounting holes, tighten the nut. Do not loosen or back off the nut.

6. Install the lock plate.

WARNING

Take care when using Loctite® to avoid serious personal injury. Follow the manufacturer's instructions to prevent irritation to the eyes and skin. If Loctite gets into your eyes, flush them with water for 15 minutes. Have your eyes checked by a doctor as soon as possible.

7. Install the lock plate mounting screws. Tighten the mounting screws to 20-30 lb-ft (27-41 N•m). **T**
 - A. The new lock plate mounting screw threads come equipped with a pre-applied locking agent.

Section 6 Assembly

- B. If you use the original lock plate mounting screws, apply two or three drops of Loctite 277 or equivalent to the internal threads of the ring gear hub.
8. Apply axle grease to the inner face of the sun gear thrust washer to help secure the washer to the nut.
9. Install the sun gear thrust washer so that the washer tangs engage the slots in the bearing adjusting nut.
10. Install the planetary sun gear and snap ring onto the axle shaft.
11. Install the axle shaft and sun gear assembly. For correct installation, the following situations must occur:
 - The axle shaft contacts the differential side gear.
 - The sun gear contacts the thrust washer.
 - The thrust washer tangs are correctly installed in the bearing adjusting nut slots.



Wheel Bearing Preload – Wheel End with Outer Bearing on Spindle Journal (PRC 425, for example)

NOTE: To adjust the wheel bearing preload, verify that the bearings are seated and the rollers are aligned correctly.

1. Install the wheel bearing adjusting nut. Tighten the nut to 400 lb-ft (542 N•m). 

WARNING

Use a brass or leather mallet for assembly and disassembly procedures. Do not hit steel parts with a steel hammer. Pieces of a part can break off and cause serious personal injury.

2. Rotate the hub in both directions. At the same time, tap the hub several times with a brass or plastic mallet.
3. Tighten the nut to 400 lb-ft (542 N•m) again. 
4. Back off the nut approximately 1/4 turn to relieve the preload produced in Step 3.
5. Tighten the nut to 200 lb-ft (271 N•m). 

WARNING

Carefully align the adjusting nut dowel pin within a ring gear tooth spline to avoid damage to the pin. A damaged dowel pin will cause the adjusting nut to back off and loosen the wheel during vehicle operation. Serious personal injury and damage to components can result.

6. Carefully align the adjusting nut dowel pin within a ring gear tooth spline to avoid damage to the dowel pin. Tighten the adjusting nut to the correct alignment. Do not back off the adjusting nut.
7. Install the planetary ring gear onto the spindle. Install the dowel pin in the adjusting nut into the hole in the ring gear face to allow the ring gear to seat against the adjusting nut.
8. Apply a thin layer of axle grease to the face of the sun gear thrust washer.
9. Install the sun gear thrust washer. The washer tangs must engage the holes in the ring gear.
10. Install the planetary sun gear and snap ring onto the axle shaft.
11. Install the axle shaft and sun gear assembly. For correct installation, the following situations must occur:
 - The axle shaft fits into the differential side gear.
 - The sun gear contacts the thrust washer.
 - The thrust washer tangs are correctly installed in the ring gear hub holes.
12. Install the O-ring on the wheel hub at the base of the flange.

Fill Wet Brake Assembly with Required Coolant

After completing the wheel end assembly, fill the brakes with the required coolant as follows:

1. Fill the brakes with the specified coolant until the coolant flows from the outlet plug opening (see **Figure 6.3**) on the piston housing. See Section 9 for required coolant.
2. Fill planetary wheel end and axle housing with required lubricants according to vehicle manufacturer's recommendations.
3. Attach forced coolant inlet and forced coolant outlet lines to the piston housing.
4. Reconnect electrical starting power to the engine. Place the transmission in neutral and start the engine. When the level in the reservoir goes down, add coolant to adjust the level to the specified position.
5. Check for leaks, bleed brake lines, and check for correct brake operation. Refer to "Remove Air from System ("Bleed" the Brakes)."

Adjust Brake with New Disc Pack

If adjuster screws were used to push the piston out of the piston housing, or the disc pack was replaced by a new disc pack, use the following procedure to adjust the brakes.

1. Ensure the three adjuster screws are installed in the piston housing and turn in halfway. Do not install jam nuts at this time. **Figure 6.3**.
2. Start the engine and remove the air from the hydraulic brake system (bleed the brakes).

CAUTION

Only install the specified petroleum-base brake actuation fluid. Do not install glycol-base automotive fluid. Damage to components can result.

3. If required, add brake actuation hydraulic fluid to bring it to the required level.
4. With the engine running, apply the brakes to build up hydraulic pressure in the brakes.

NOTE: Keep brakes applied until all three screws are adjusted.

5. With brake applied, turn the brake adjuster screws **CLOCKWISE** until they stop turning. The screws are now bottomed on the piston.
6. With the brakes still applied, rotate each screw **COUNTERCLOCKWISE** one full turn (back off the brakes).
7. Matchmark each screw to the housing. Do not allow the screws to turn after marking.
8. Release the brakes.
9. Apply silicone sealant to the interface between the piston housing and each adjuster screw. Do not apply to the jam nuts.
10. Install the jam nuts onto the adjuster screws. Using a suitable wrench to prevent the screws from turning, tighten each jam nut to 25-35 lb-ft (34-47 N•m). 

Section 6 Assembly

Remove Air from the System ("Bleed" the Brakes)

WARNING

You must bleed the brakes to remove all air from the system when you loosen any brake system hydraulic connection. Air can prevent hydraulic pressure from applying the brakes correctly and can increase stopping distance. Serious personal injury and damage to components can result.

Use only the type of hydraulic fluid specified by the equipment manufacturer. Do not use or mix different types of hydraulic fluid. Using incorrect hydraulic fluid will damage the rubber parts of the brake. Loss of braking control, serious personal injury and damage to components can result.

CAUTION

Do not reuse hydraulic fluid or coolant. Used fluid can be contaminated and can cause incorrect operation. Damage to components can result.

Only install the specified petroleum-base brake actuation fluid. Do not install glycol-base automotive fluid. Damage to components can result.

NOTE: Always start at the point in the system that is farthest from the master cylinder and work back toward the master cylinder.

1. Put a clear tube on the bleeder screw. Submerge the opposite end of the tube into a clear container of the specified hydraulic fluid.
2. When you complete a wheel, go to the bleeder screw on the next closest wheel.
3. Use the following instructions to bleed the brakes.

Air/Hydraulic or Mechanical Actuator Systems

NOTE: Always start at the point in the system that is farthest from the master cylinder and work back toward the master cylinder.

1. Check that the master cylinder is filled to the correct level with hydraulic fluid specified by the component manufacturer. Keep the master cylinder filled when you bleed the brakes, so air does not enter the system through the master cylinder.
2. Apply the brake pedal.
3. Loosen the bleeder screw.
4. Tighten the bleeder screw before you release the brake pedal so that air does not enter the system. 
5. Repeat until there are no air bubbles in the hydraulic fluid when you apply the brake pedal and loosen the bleeder screw.
6. Check for fluid leaks.
7. When you have finished bleeding the brakes, check that the master cylinder is filled to the correct level.

Full Hydraulic Systems

NOTE: Always start at the point in the system that is farthest from the master cylinder and work back toward the master cylinder.

1. Slowly apply low hydraulic pressure to the brake. Loosen the bleeder screw.
2. Continue to apply pressure until no air bubbles appear in the container of fluid.
3. Tighten the bleeder screw 15-20 lb-ft (20-27 N•m), then release the pressure to the brake. 
4. Check for fluid leaks.
5. When you have finished bleeding the brakes, check that the master cylinder is filled to the correct level.

WARNING

To prevent serious eye injury, always wear safe eye protection when you perform vehicle maintenance or service.

Coolant Change Intervals

WARNING

To avoid injury from the hydraulic fluid, allow the brakes to cool to ambient temperature (cool to the touch) before draining fluid. Wear protective gloves.

Use only the type of fluid specified by the equipment manufacturer. Do not use or mix different types of fluid. An incorrect fluid can damage the rubber parts of the assemblies, which could cause loss of braking and serious personal injury.

Do not reuse hydraulic fluid or coolant. Used fluid may be contaminated and can cause incorrect operation, which can result in serious personal injury and damage to components.

Hydraulic disc brake assemblies with forced cooling systems use a pump to move coolant in and out of the housings. Coolant is supplied from a reservoir. The movement of coolant removes heat from the discs. At specified times the coolant must be changed in the complete brake cooling system.

Change brake coolant at the following intervals:

- **First Coolant Change:** Change coolant after the first month or after the first 200-250 hours of operation, whichever comes first.
- **Regular Periodic Maintenance:** Change coolant every six months or every 3,000 hours of operation, whichever comes first.

Coolant Draining and Filling

Hub seals are used in each wheel end assembly to retain the TOU (tractor oil universal) fluid that cools the brake discs. Refer to Section 9 for fluid recommendations. At the specified intervals, change the coolant in each brake assembly. Use the following procedure:

1. Make sure the axle and brake assembly are in a level position.
2. Place a suitable container under the brake to catch the drained coolant.

CAUTION

Matchmark the brake disc adjuster screw position before loosening the jam nut. Hold the adjuster screw in place to prevent its movement. Loosening the jam nut may result in improperly adjusted brakes when the screw and jam nut are reinstalled. This can lead to uneven brake disc wear and accelerate brake disc wearout.

3. Matchmark the bottom adjuster screw to the brake piston housing. **Figure 7.1.** Reinstall the bottom adjuster screw to the same depth in the piston housing to ensure correct brake adjustment and even brake disc wear.

CAUTION

Hold adjuster screw in place. Do not allow adjuster screw to turn. If adjuster screw turns, damage to components can result.

4. Place a suitable wrench onto the bottom adjuster screw. Hold the screw in position to keep it from moving. With the screw held securely, turn the jam nut COUNTER-CLOCKWISE to loosen.

Section 7 Maintenance

Figure 7.1

PLUG AND SCREW LOCATIONS
ON BRAKE PISTON HOUSING

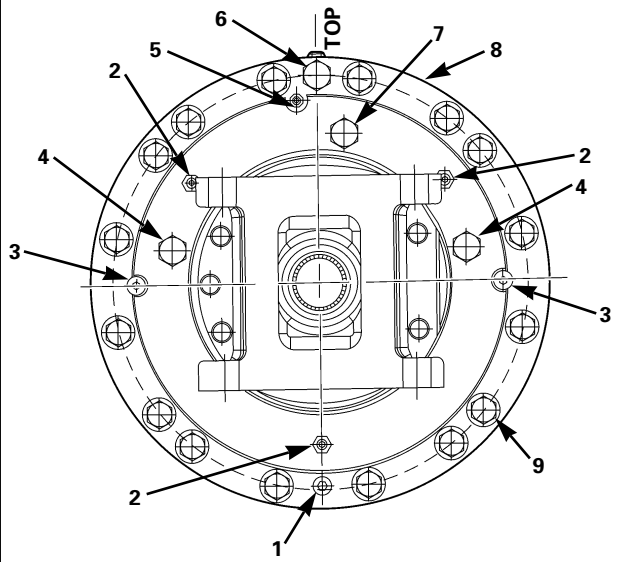

1. Plug, Magnetic Drain (1)
2. Adjuster Screw with Jam Nut (3)
3. Plug, Actuation Fluid Inlet (2)
4. Plug, Forced Cooling Outlet (2)
5. Screw, Actuation Fluid Bleeder (1)
6. Plug, Forced Cooling Inlet (1)
7. Plug, Air Evacuation (1)
8. Housing, Brake Piston (1)
9. Capscrew, Brake Piston Housing to Disc Housing (16)

- Remove the bottom adjuster screw from the piston housing. Count the number of rotations required to remove the screw and record this number.

NOTE: Install the screw with the same number of turns used to remove it. Line it up with the matchmark line on the housing to bring the brake to the original adjustment.

- Remove the recessed Allen-head magnetic drain plug directly below the adjusting screw opening. Allow the coolant to drain from the housing into the container.
- Dispose of the used fluid in a manner according to state and/or federal (EPA) recommendations.
- Clean the magnetic drain plug. Apply silicone sealant to the threads of the plug, install in the piston housing, and tighten to 25-35 lb-ft (34-47 N•m).

- Clean the adjuster screw. Install it in the piston housing as follows:

A. Insert the screw in the housing.

NOTE: Install the screw with the same number of turns used to remove it. Line it up with the matchmark line on the housing to bring the brake to the original adjustment position.

B. Slowly rotate it **CLOCKWISE** the same number or turns used for removal.

- Apply silicone sealant to the interface between the base of the adjuster screw and the housing. Install the jam nut lightly onto the screw.

CAUTION

Hold the adjuster screw in place. Do not allow the adjuster screw to turn. If the adjuster screw turns, damage to components can result.

- Use a suitable wrench to prevent movement of the screw. Use a torque wrench to tighten the jam nut to 25-35 lb-ft (34-47 N•m).
- Remove the hex-head air evacuation plug and the plug from the unused forced cooling outlet opening. **Figure 7.1.**
- Fill the brake with the specified coolant until the coolant flows from the forced cooling outlet plug opening. Refer to Section 9.
- Install the air evacuation plug and the forced cooling outlet plug in the housing, and tighten to 60-75 lb-ft (81-102 N•m).
- Place the transmission in Neutral and start the engine. When the level in the reservoir goes down, add coolant to adjust the level to the specified position. Operate the brakes.
- Check for leaks.

CAUTION

Do not use automotive (glycol-base) brake fluid in place of required petroleum-base brake actuation fluid, since this can result in seal damage (swelling).

- Bleed the brakes and check for correct brake operation.

Section 8 Troubleshooting

Brake Does Not Apply

Condition	Possible Causes	Correction
Low or no pressure to brake.	<ol style="list-style-type: none"> 1. Empty fluid reservoir. 2. Damaged hydraulic system 3. Leakage of brake actuation fluid. 	<ol style="list-style-type: none"> 1. Fill reservoir to correct level with specified fluid. 2. Repair the hydraulic system. 3. Refer to "Brake Leaks Actuation Fluid" in this section.

Brake Does Not Release

Condition	Possible Causes	Correction
Vehicle does not move.	Damaged hydraulic system.	Repair hydraulic system.
Brakes dragging.	<ol style="list-style-type: none"> 1. More than 1.1 bar (16 psi) pressure applied when brakes released. 2. Damaged piston return spring assembly. 3. Piston not returning. 4. Wrong cooling and/or actuation fluid used. 5. Parking brake not adjusted correctly. 	<ol style="list-style-type: none"> 1. Repair hydraulic system so pressure is less than 1.1 bar (16 psi) when brakes released and while machine is operating in any mode. 2. Repair or replace piston return spring assembly. 3. Check piston seals for swelling or damage. Replace as necessary. 4. Check piston seals for swelling or damage. Replace as necessary. Purge system and use specified fluid. 5. Adjust parking brake.

Braking Performance

Condition	Possible Causes	Correction
Noticeable change or decrease in stopping performance.	<ol style="list-style-type: none"> 1. Inadequate actuation fluid supply to brakes. 2. Inadequate pressure to apply brakes. 3. Worn or damaged discs. 4. Overheated seals and/or discs 5. Dirty or contaminated cooling fluid. 	<ol style="list-style-type: none"> 1. Replenish fluid in brake system. Check for leakage and correct cause. 2. Check brake apply system. Check for leakage in brake system or brakes, and correct cause. 3. Inspect and replace discs if necessary. NOTE: As disc wear occurs, make sure brake system can supply adequate fluid to fully apply brakes. 4. Inspect and replace discs and seals if necessary. 5. Drain and flush cooling fluid from brakes and entire brake system. Replace with approved fluid. In some cases, it may be necessary to replace discs. Clean or replace filter.
Brake does not fully apply.	<ol style="list-style-type: none"> 1. Empty fluid reservoir. 2. Damaged hydraulic system. 3. Leakage of brake actuation fluid. 	<ol style="list-style-type: none"> 1. Fill reservoir to correct level with specified fluid. 2. Repair hydraulic system. 3. Refer to "Brake Leaks Actuation Fluid" in this section.
Brakes feel spongy/soft.	Brakes or brake system not correctly bled.	Bleed brakes and brake system.

Section 8

Troubleshooting

Brake Leaks Actuation Fluid

Condition	Possible Causes	Correction
Internal leak: Fluid bypasses seals into axle and fills axle with fluid and blows out breather or empties brake fluid reservoir.	<ol style="list-style-type: none"> 1. Worn or damaged piston seal. 2. Melted or extruded piston seals. 3. Corrosion, pitting, wear or other damage, marks, scratches to piston and/or brake housing bore in area of seal/sealing lips. 4. Incorrect brake actuation fluid. 	<ol style="list-style-type: none"> 1. Replace piston seals. 2. Correct cause of overheating and replace seals. 3. Clean, smooth, rework or replace affected parts. 4. Check piston seals for swelling or damage. Replace as necessary. Purge system and use specified fluid.
External leak	<ol style="list-style-type: none"> 1. Loose bleeder screw. 2. Loose inlet fitting or plugs 3. Damaged inlet fitting or plugs or damaged seats 	<ol style="list-style-type: none"> 1. Tighten bleeder screw to 20-27 N•m (15-20 lb-ft). 2. Tighten inlet fitting to 34-47 N•m (25-35 lb-ft). 3. Replace inlet fitting or plug and O-ring if used. Repair or resurface area; or replace as necessary.

Brake Cooling Fluid Leakage

Condition	Possible Causes	Correction
Coolant leaking out of brake housing.	<ol style="list-style-type: none"> 1. Face seal damaged, worn or incorrectly installed. 2. Loose drain plug, fill plug, or forced cooling plug. 3. Damaged plug. 4. Deteriorated or inadequate sealant used at joint. 	<ol style="list-style-type: none"> 1. Reinstall and/or replace face seal. 2. Tighten plug. 3. Replace plug and O-ring, if used. 4. Disassemble, clean, re-seal and reassemble joint.
Axle housing filling with oil (forced cooling systems only) and may be forced out the breather.	<ol style="list-style-type: none"> 1. Worn or damaged spindle to hub seal. 2. Brush hair lodged in grease under hub-to-spindle seal lip. 	<ol style="list-style-type: none"> 1. Replace spindle to hub seal and check seal journals. 2. Do not use brush to apply grease to seal areas.

Brake Noise and Vibration

Condition	Possible Causes	Correction
Brakes produce noise, chatter, vibration	Incorrect axle fluid and/or friction material used.	<ol style="list-style-type: none"> 1. Use only RICO specified or approved materials. 2. Drain and flush fluid from axle. Replace with approved fluid. 3. Replace all friction discs. Thoroughly clean or replace stationary discs.

Section 8 Troubleshooting

Brake Overheats

Condition	Possible Causes	Correction
Overheating due to excessive duty cycle.	Inadequate coolant flow or heat exchange.	<ol style="list-style-type: none"> 1. Install brake cooling system if not already installed on vehicle. 2. Re-analyze and re-size brake cooling system if necessary.
Inadequate coolant flow.	Low pump output, blocked filter or coolant lines.	Check pump output at different operating modes. Replace filter and check lines.
Low or no coolant	<ol style="list-style-type: none"> 1. Incorrect fill or leaks 2. Leaking face seal. 3. Loose or damaged plugs. 4. Deteriorated or inadequate sealant used at joint. 	<ol style="list-style-type: none"> 1. Check for correct fill level. 2. Replace or reinstall face seal assembly. 3. Tighten drain, fill or forced cooling plug. Replace if damaged. 4. Disassemble, clean, re-seal and re-assemble brake housing joint.
Brake drags.	<ol style="list-style-type: none"> 1. More than 1.1 bar (16 psi) pressure applies when brakes released. 2. Damaged piston return spring assembly. 3. Piston not returning. 4. Wrong cooling and/or actuation fluid 5. Tight or damaged splines (eg., friction disc-to-hub driver.) 	<ol style="list-style-type: none"> 1. Repair hydraulic system so pressure is less than 1.1 bar (16 psi) when brakes released and while machine is operating in any mode. 2. Repair or replace piston return spring assembly. 3. Check piston seals for swelling or damage. Replace as required. 4. Check piston seals for swelling or damage. Replace as required. Purge system and use correct fluid. 5. Repair or replace parts.

Section 9 Specifications

Plug and Screw Torque on Brake Piston Housing

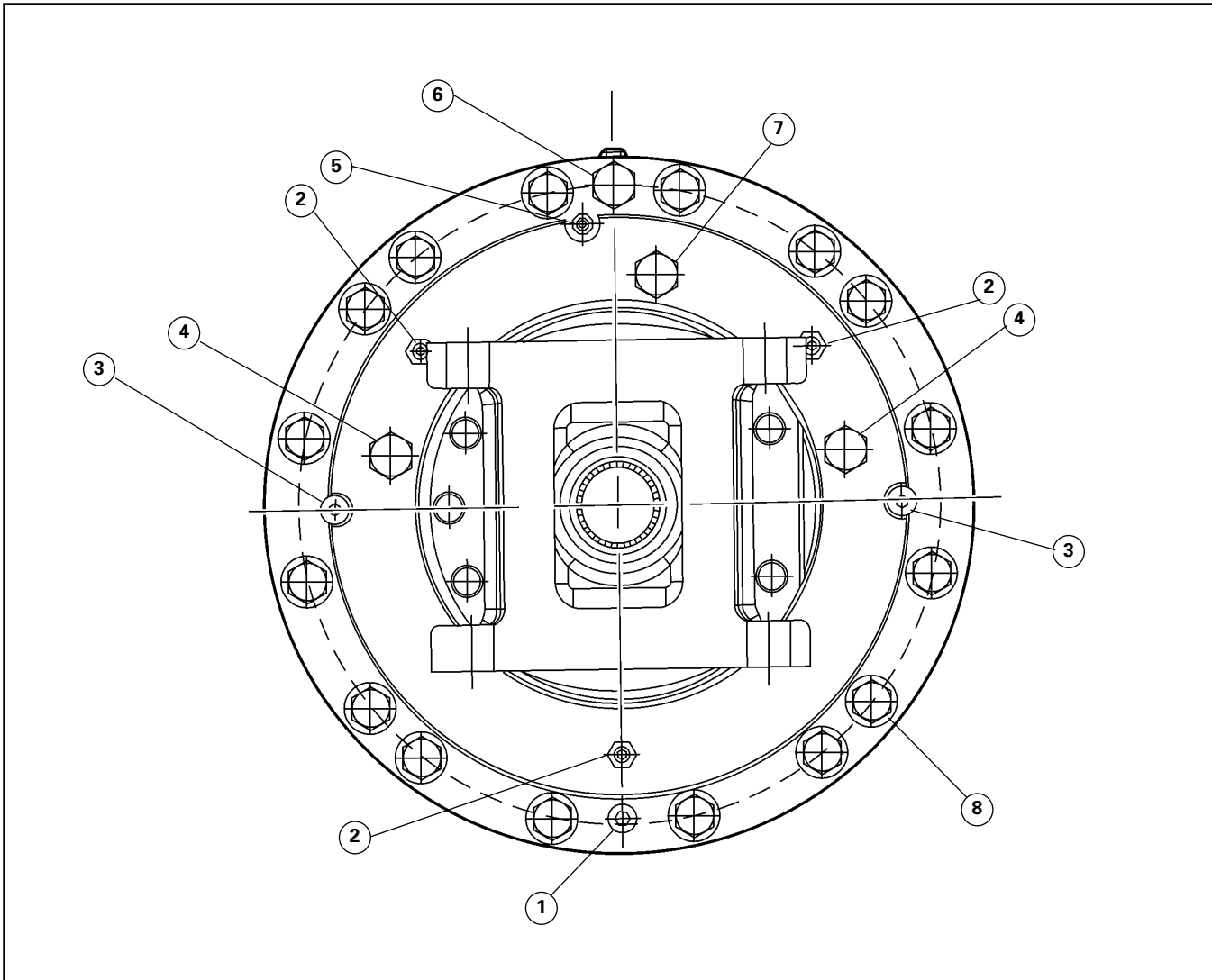

Item	Fastener	Torque Value
1	Plug, Magnetic Drain (1)	25-35 lb-ft (34-47 N•m)
2	Adjuster Screw with Jam Nut (3)	25-35 lb-ft (34-47 N•m)
3	Plug, Actuation Fluid Inlet (2)	25-35 lb-ft (34-47 N•m)
4	Plug, Forced Cooling Outlet (2)	60-75 lb-ft (81-102 N•m)
5	Screw, Actuation Fluid Bleeder (1)	15-20 lb-ft (20-27 N•m)
6	Plug, Forced Cooling Inlet 1)	60-75 lb-ft (81-102 N•m)
7	Plug, Air Evacuation (1)	60-75 lb-ft (81-102 N•m)
8	Capscrew, Brake Piston Housing to Disc Housing (16)	Initial: 150 lb-ft (203 N•m) Final: 200-258 lb-ft (270-350 N•m)

Section 9 Specifications

W3H Wheel End Torque Chart for the PRC 775

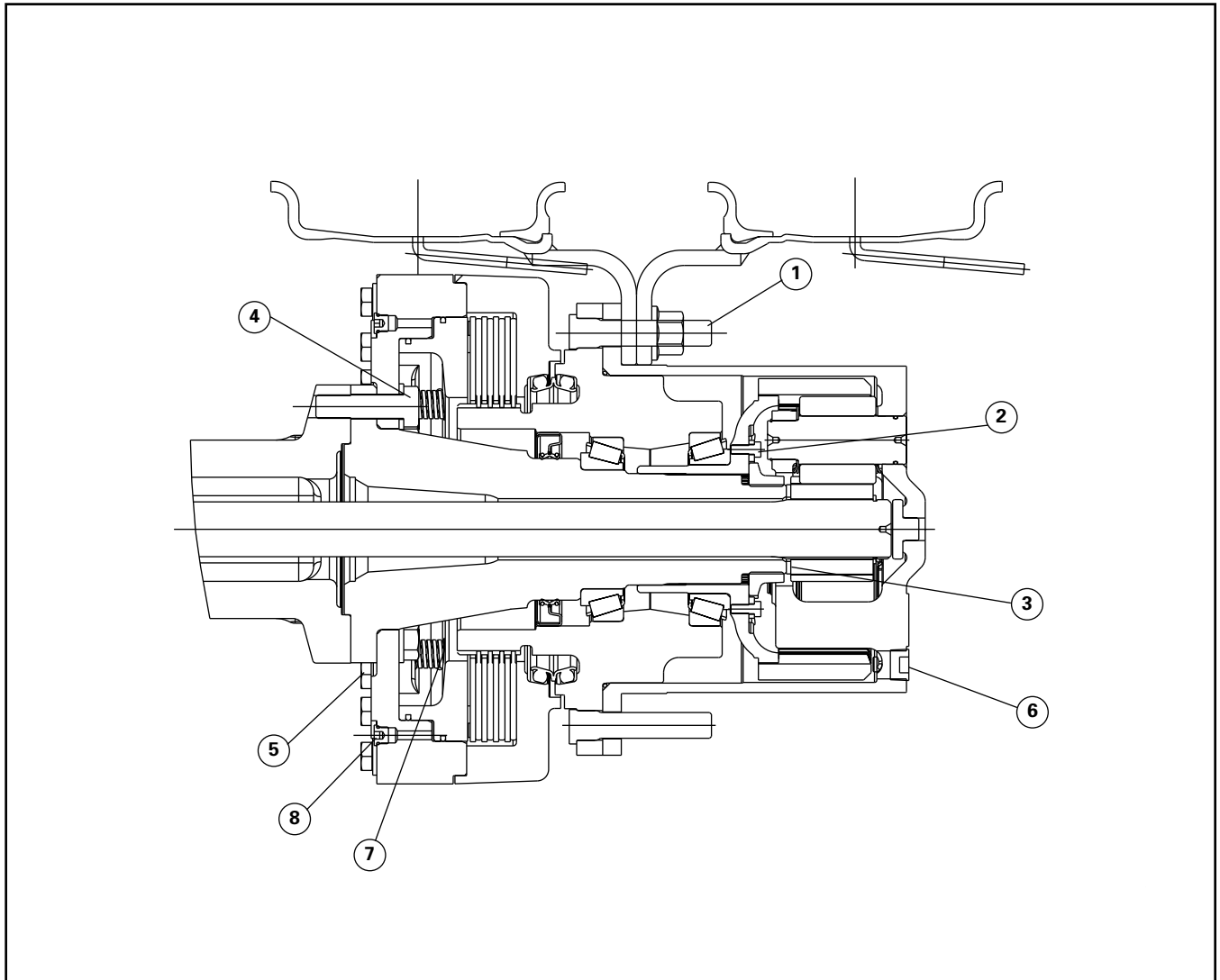

Item	Fastener	Torque Value
1	Wheel rim nut	Per OEM specification
2	Lock plate screw	20-30 lb-ft (27-41 N•m)
3	Wheel bearing adjusting nut	Initial = 400 lb-ft (542 N•m)* Final = 200 lb-ft (271 N•m)*
4	Spindle and wet disc brake mounting	370-480 lb-ft (500-650 N•m)
5	Brake housing capscrews	200-258 lb-ft (270-350 N•m)
6	Oil fill/drain plug	35 lb-ft (47 N•m)
7	Piston return spring shoulder bolts	22-30 lb-ft (30-40 N•m)
8	Actuation fluid inlet fitting	25-35 lb-ft (34-47 N•m)

*Refer to instructions in Section 5 of Maintenance Manual 9K.

Section 9 Specifications

W3H Wheel End Torque Chart for the PRC 425

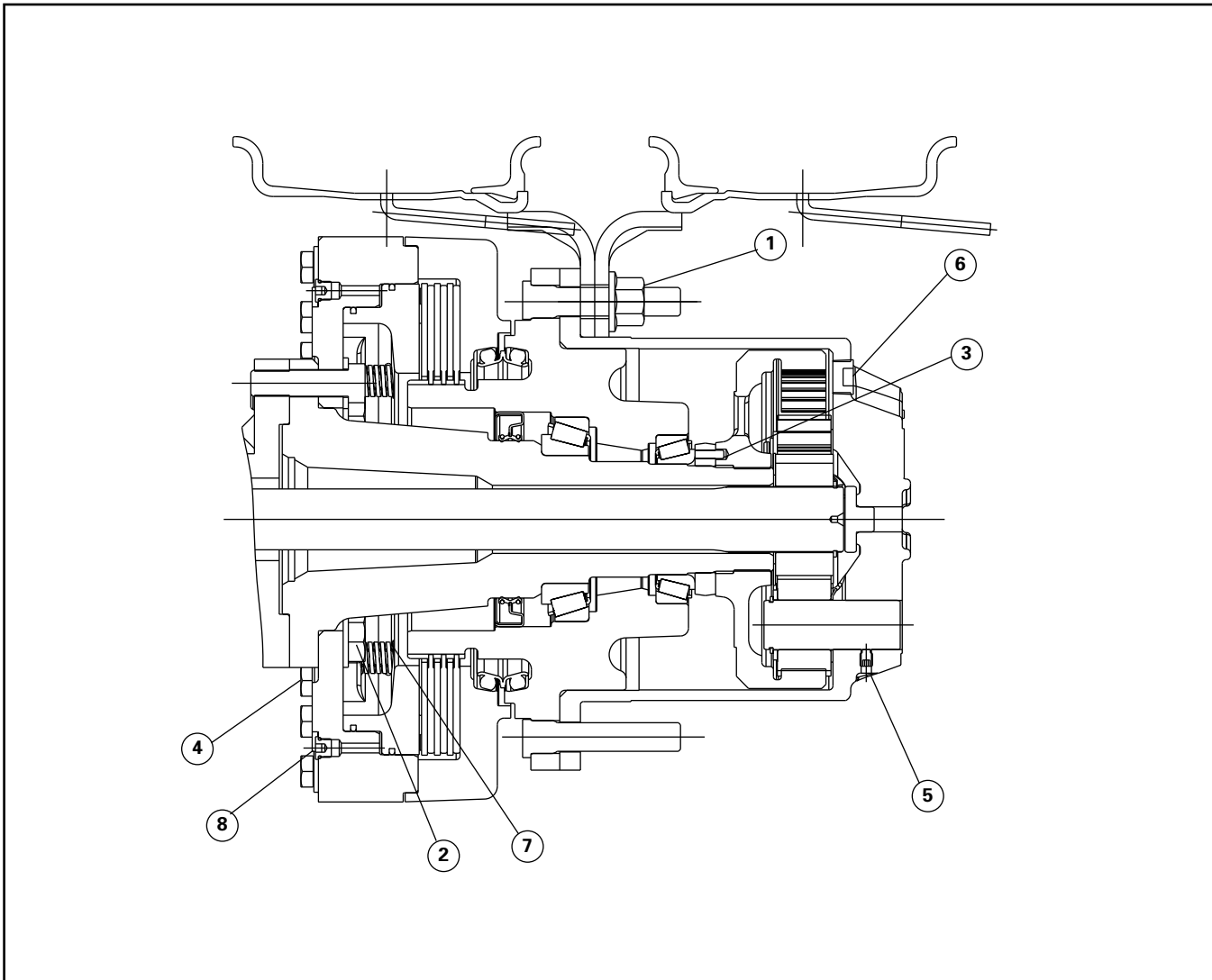

Item	Fastener	Torque Value
1	Wheel rim nut	Per OEM specification
2	Spindle and wet disc brake housing mounting	370-480 lb-ft (500-650 N•m)
3	Wheel bearing adjusting nut	Initial = 400 lb-ft (542 N•m)* Final = 200 lb-ft (271 N•m)*
4	Brake housing capscrews	200-258 lb-ft (270-350 N•m)
5	Pinion shaft setscrew	35 lb-ft (47 N•m)
6	Oil fill/drain plug (not shown)	35 lb-ft (47 N•m)
7	Piston return spring shoulder bolts	22-30 lb-ft (30-40 N•m)
8	Actuation fluid inlet fitting	25-35 lb-ft (34-47 N•m)

*Refer to instructions in Section 3 of Maintenance Manual 9K.

Section 9 Specifications

Minimum Brake Disc Thickness

Disc Type	Part Number	Minimum Thickness
Friction	A-3281-Z-1196	0.192 Inch (4.87 mm)
Stationary	3281-F-1203	0.167 Inch (4.25 mm)

Hydraulic Fluid for Brake Actuation*



CAUTION

Do not use automotive (glycol-base) brake fluid in place of required petroleum-base brake actuation fluid, since this can result in seal damage (swelling).

Component	Example
Petroleum Base Hydraulic Fluid (Mineral Oil)	Meets MIL-H-5606 specifications

*See fluid and specification recommendations of equipment manufacturer.

Brake Coolant Specifications: Sump and Forced Cooling Systems with Hub Seals

Coolant	Specification
Petroleum Base SAE 10W, SAE 20W or SAE 10W30	See the recommendations of the vehicle manufacturer.



CAUTION

The operating temperature of the coolant must never reach or exceed 250°F (120°C). If the operating temperature of the coolant reaches or exceeds 250°F (120°C), the internal components of the brake will be damaged. A forced cooling system may be required to assure the coolant temperature remains below 250°F (120°C).

Tractor oil universal fluid, "TOU" types formulated for wet disc brakes is recommended for use in the wet disc brake housing. Make sure that the specifications of the tractor fluid are the same as the recommended specifications of the vehicle manufacturer.

Coolant Change Intervals

Break-In Interval:	Change the fluid in the brake housing after the first month or the first 200-250 hours of operation, whichever comes first.
Normal Maintenance Interval:	Change the fluid every 6 months or every 3000 hours of operation, whichever comes first.

Hydraulic Fluid Specifications

Use only the brake hydraulic fluid specified by the manufacturer of the vehicle. Do not use different hydraulic fluids. The wrong fluid will damage the seals on the piston.

Lubrication

Maintenance Manual 1

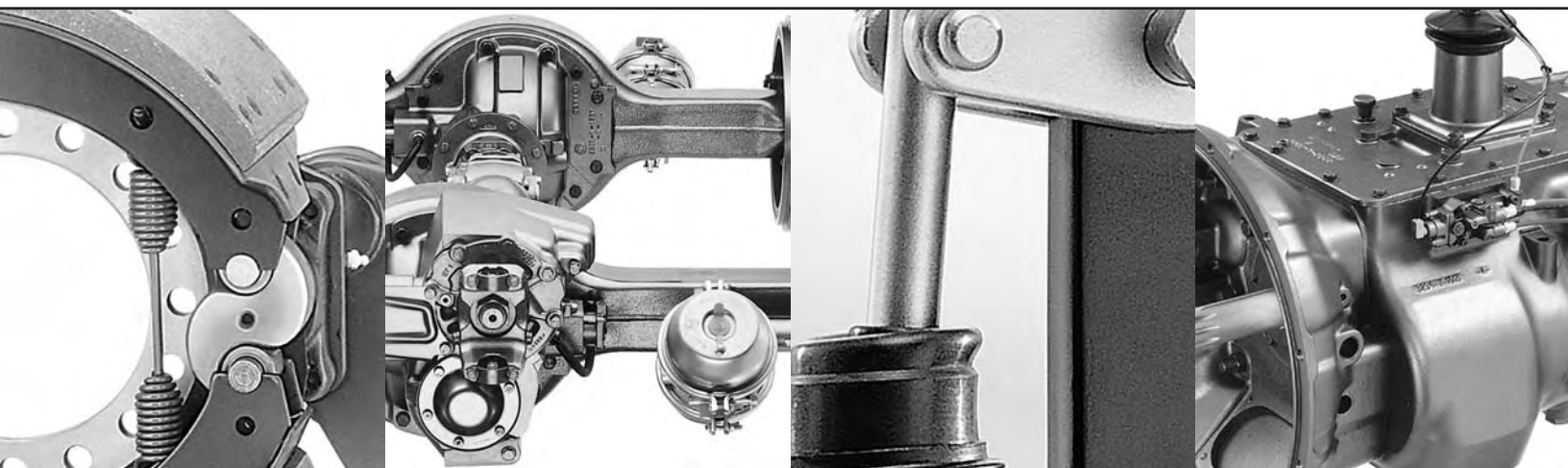

- Q Plus™ Cam Brake
- Tandem Axle with Pump, Filter System and Driver-Controlled Differential Lock (DCDL)
- Automatic Slack Adjuster
- ZF RICO Ten-Speed Transmission

Service Notes

Before You Begin

This manual provides maintenance intervals and procedures, lubricant specifications, and product capacities for RICO and ZF RICO components.

1. Understand all procedures and instructions.
2. Follow your company's maintenance and service, installation, and diagnostics guidelines.
3. Use special tools when required to avoid serious personal injury and damage to components.

Maintenance Information for Components Included in This Manual

Safety Alerts, Torque Symbol and Notes



 WARNING	A Warning alerts you to an instruction or procedure that you must follow exactly to avoid serious personal injury and damage to components.
 CAUTION	A Caution alerts you to an instruction or procedure that you must follow exactly to avoid damage to components and possible serious injury.
	A torque symbol alerts you to tighten fasteners to a specified torque value.
NOTE	A Note provides information or suggestions that help you correctly service a component.

Table of Contents

Section 1: Introduction

Introduction	
Regularly-Scheduled Maintenance is Important	
Oil Lubricants	
Viscosity	
Oil Change Schedules	
Recommended Oil Drain Conditions Based on Used-Oil Analyses	2
Differential Oils (Hypoid Gear Oils)	
Manual Transmission Oils	
Grease Lubricants	
National Lubricating Grease Institute (NLGI) Standards	3
Extreme Pressure (EP) Lubricants	

Section 2: Clutches

Release Bearing	4
Bell Housing	
Clutch Linkage	5

Section 3: Drivelines

Driveline Styles	6
RPL Series Permalube™ Driveline Universal Joint, Slip Yoke and Splines	
Standard/Conventional Driveline Universal Joint	
Standard/Conventional Driveline Slip Yoke and Splines	
92N Permalube Driveline Universal Joint	7
92N Greaseable Driveline Universal Joint	
92N Permalube and Greaseable Driveline Slip Yoke and Splines	

Section 4: Front Driving Axles

Front Driving Axles	9
Magnets and Magnetic Drain Plugs	
Breather	
Seals	
Temperature Indicators	
Oil Level	
Drain and Replace Oil	
Wheel Bearings and Wheel-Ends	
Knuckle King Pins	10
Camshaft Retainer Bushing and Cam Bushing	
Drive Axle Shaft Universal Joint	
Axle Shaft Spline and Thrust Washer	
Cross Tube End Assembly	
Knuckle Bushing	

Section 5: Front Non-Driving Axles

King Pins	13
Conventional Front Axles	
Sealed and Easy Steer™ Front Axles	
Easy Steer Plus™ Front Axles	14
Ball Studs on the Steering Arm, Tie Rod Arm Ends and Drag Link	
Conventional Front Axles, Easy Steer Front Axles, Easy Steer Plus Front Axles	
Wheel Bearings and Wheel-Ends	
Conventional Front Axles, Easy Steer Front Axles, Easy Steer Plus Front Axles	

Section 6: On-Highway Brakes

Q Plus™ LX500 Cam Brake Package with the Extended Lube Feature	16
Available for On-Highway Linehaul and All Other Applications	
Q Plus™ MX500 Extended Maintenance Package Option	
Available for On-Highway Linehaul Applications Only	
Identifying Q Plus™ LX500 and MX500 Cam Brakes	
Lubricating the Q Plus™ LX500 and MX500 Cam Brakes and Automatic Slack Adjusters	
After Specified Mileage or Time Intervals	
Camshaft Bushings	17
Q Plus™, Cast Plus™, Q Series, P Series and T Series Cam Brakes	

Table of Contents

Section 7: Planetary Drive Axles

Magnets and Magnetic Drain Plugs	20
Breather	
Seals	
Temperature Indicators	
Check and Adjust the Oil Level	
Drain and Replace the Oil	21

Section 8: Rear Drive Axles

Magnets and Magnetic Drain Plugs	24
Breather	
Seals	
Temperature Indicators	25
Advanced Lube Axles	
For RICO R-170 Axles Equipped With Traction Equalizer®	
When to Use Limited Slip Friction Modifiers	
Specifications	
Oil Level	
Check and Adjust the Oil	26
Drain and Replace the Oil	
Inter-Axle Assemblies With Separate Housings	

Section 9: Trailer Axles

TB Series Trailer Axles With Unitized Hub Assemblies	31
Comparing a Unitized Wheel-End to a Conventional Wheel-End	
Identifying a Trailer Axle With Unitized Wheel-Ends	32
Wheel Bearings and Wheel-Ends	
Camshaft Bushings	
Conventional and TB Series	

Section 10: Transfer Cases

Operating Information	35
Magnets and Magnetic Drain Plugs	
Breather	
Seals	
Temperature Indicator	
Check and Adjust Oil Level	
Drain and Replace the Oil	36

Section 11: Transmissions

Recommended Oil Drain Conditions Based on Used-Oil Analysis	38
Manual Transmission Oils	
Magnets and Magnetic Drain Plugs	
Transmission Oil Coolers	
Temperature Indicator	
Oil Level	
Before You Check the Oil Level	
Check and Adjust the Oil Level	39
Drain and Replace the Oil	
Service the Transmission if Necessary	
Additional Specifications, Ratios and Steps	41

Section 12: Wheel Bearings and Wheel-Ends

Wheel Bearings	49
Grease the Bearings	
Check the Oil Level	
Drive Axle Hubs Without Fill Holes	50

Section 13: List of Lubricants

	51
--	----

Introduction

This manual provides Meritor's grease and oil lubricant specifications, procedures, service intervals and product capacities. Following these guidelines will enable you to correctly lubricate and maintain RICO components, and help to ensure maximum component life.

- Always use the specified oil or grease lubricant from a manufacturer that provides quality products and complete application instructions.
- Always follow recommended lubrication intervals and procedures.

Regularly-Scheduled Maintenance is Important

Internal components can shed fine metal wear particles at a steady rate, especially during the break in period. If wear particles, moisture and other contaminants are allowed to circulate in the lubricant, the components will wear at a faster rate than normal.

Regularly-scheduled maintenance using the specified lubricants will help to ensure maximum component performance and life.

Oil Lubricants

There are three types of oil lubricants: petroleum oil, full synthetic oil and semi-synthetic oil. Both full synthetic and semi-synthetic oils retain their lubrication properties longer than petroleum oil.

- Petroleum oil is derived from crude oil. Crude petroleum oil also yields combustible fuels and a wide range of petroleum chemicals.
- Full synthetic oil uses a man-made-base oil with predictable physical properties. Full synthetic oil contains no refined petroleum-based fluids.
- Semi-synthetic oil contains a mixture of petroleum-based and synthetic fluids that can help extend service intervals, improve cold weather properties and reduce volatility.

Viscosity



Use correct viscosity lubricants recommended by RICO. Do not lower the viscosity of specified lubricants by adding thinning agents, such as kerosene, gasoline or other dilutents. Damage to components will result.

Select the correct viscosity oil for a specific RICO component from the charts in each section of this manual. When more than one lubricant is listed, choose an oil viscosity that is suitable for the expected outside temperature.

Oil viscosity grades and classifications are provided by the SAE (Society of Automotive Engineers) and the API (American Petroleum Institute).

- Use **multigrade oils** when vehicles operate in both cold and warm weather between oil changes.
- Use **low viscosity single grade oils** only in cold climates. **Single grade 75W oils are not approved for use in drive axles where ambient (outside) temperatures exceed 40°F (4°C).**
- Use **multigrade oil** for drive axles only. The hypoid gearing requires a GL-5 oil with Extreme Pressure (EP) additives to provide adequate lubricant film protection that prevents gear failure.

Oil Change Schedules

To determine an oil change schedule, take an oil sample at a specified interval or mileage recommendation. Analyze the sample to establish a schedule.

Often, however, service duty will dictate when to change the oil, regardless of mileage or a previously-established schedule.

Section 1

Introduction

Recommended Oil Drain Conditions Based on Used-Oil Analyses

Differential Oils (Hypoid Gear Oils)

Drain and replace used differential oil that does not meet with the following used-oil analyses. Replace the drained oil with RICO-specified oil for hypoid drive axle use.

Used-Oil Analyses (ppm=parts per million)

Iron (Fe)	If level is between 1000 ppm and 1500 ppm, resample the oil. If resampling indicates that iron level is above 1000 ppm, drain and replace the oil. If level is above 1500 ppm, drain and replace the oil.
Silicon (Si)	If level is greater than 100 ppm, drain and replace the oil.
Water (H ₂ O)	If level is greater than 0.3%, drain and replace the oil.
Phosphorus (P)	If level is <u>less than</u> 900 ppm, it is possible that the oil is not a GL-5 gear oil. Contact the lubricant manufacturer or RICO Materials Engineering to determine the expected phosphorus level of a new oil sample. Only GL-5 type gear oils are approved for use in RICO differentials.
Toluene Insolubles	If level is greater than 0.100 wt.%, drain and replace the oil.

Manual Transmission Oils

If used transmission oil analyses indicate that any one of these criteria is not met, drain the used oil and replace it with an oil that is recommended for manual transmissions.

Used-Oil Analyses (ppm = parts per million)

Iron (Fe)	If level is greater than 500 ppm, drain and replace the oil.
Silicon (Si)	If level is greater than 100 ppm, drain and replace the oil.
Water (H ₂ O)	If level is greater than 0.3%, drain and replace the oil.

Grease Lubricants

- Grease lubricants contain three substances: oil, a thickener base and additives.
- The oil lubricates. The thickener (base) holds the oil in place and releases it to provide the necessary lubrication. The additives enhance the characteristics of the oil and thickener. Extreme Pressure (EP) additives help prevent scoring, galling and welding of moving parts.
- The thickener may be a simple or complex soap (lithium, calcium, aluminum, etc.), organic (polyurea) or inorganic (clay).
- Do not mix different types of greases. The possibility of incompatible greases may reduce the lubricating ability of the greases.
- An important property of a grease is its dropping point, the temperature where grease changes from a semi-solid state to a liquid state. However, the operating temperature of a specific grease is not determined solely by the dropping point.

Other properties such as resistance to change in consistency and chemical deterioration at high temperatures must be considered.

National Lubricating Grease Institute (NLGI) Standards

The National Lubricating Grease Institute (NLGI) classifies and grades grease lubricants according to a grease's consistency and the application for which it is used.

The NLGI also issues licensed labels that identify approved grease lubricant applications.

Extreme Pressure (EP) Lubricants

CAUTION

Do not use multi-viscosity or Extreme Pressure (EP) GL-5 gear oils in a manual transmission. Damage to the transmission will result.

Extreme Pressure lubricants are often identified by the abbreviation "EP." Extreme Pressure lubricants contain additives that provide extra anti-wear protection to heavily-loaded parts. RICO requires either EP greases or EP oils in various applications.

Approved hypoid gear oils contain EP additives that protect against tooth scoring and surface fatigue.

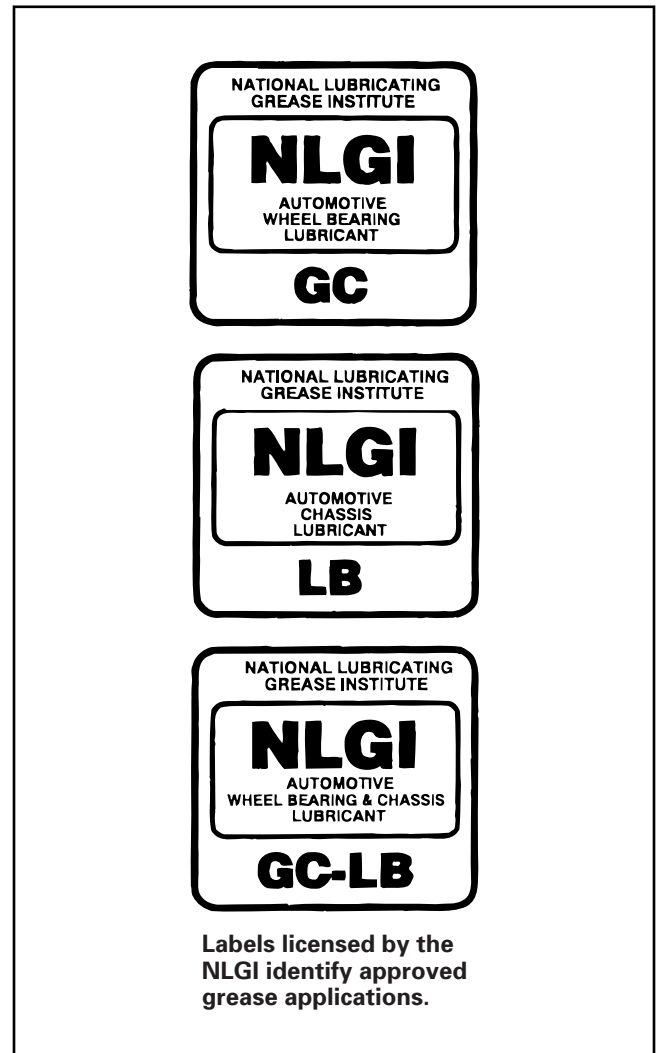

Section 2 Clutches

WARNING

To prevent serious eye injury, always wear safe eye protection when you perform vehicle maintenance or service.

Release Bearing

CAUTION

Make sure the inspection cover on the clutch housing is used. If an inspection cover is not used, dirt and contaminants enter the clutch housing and damage the clutch.

1. Remove the inspection cover on the clutch housing.
2. Clean all grease fittings prior to lubrication.
3. Correctly lubricate the release bearing. Apply grease to the grease fitting on the release bearing until you can see a small amount of grease coming out of the bearing housing. Do not overgrease.
4. Apply grease to the release yoke tips where they contact the bearing housing. Also apply grease to the exposed transmission input shaft between the bearing housing and the transmission input bearing retainer to lubricate the release sleeve bushing.
5. If the release bearing is equipped with a lube tube, be sure that you can see grease coming out of the bearing housing, which ensures that lubricant is reaching the bearing. Be sure that the lube tube is secured and not damaged.
6. Use the same procedure for extended maintenance clutches.
7. Install the inspection cover. RICO recommends using a high temperature, multi-purpose wheel bearing grease (RICO Specification O-661), but use the lubricant recommended by the manufacturer of the vehicle. **Figure 2.1.**

Figure 2.1

RELEASE BEARING LUBRICATION POINTS

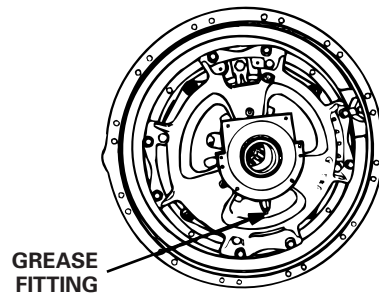

Bell Housing

1. Clean all grease fittings prior to lubrication.
2. Grease the release fork cross shaft by applying grease to each fitting on the bell housing until a small amount of grease purges out. Use the specified lubricant at the recommended interval. Refer to the lubricant specifications and maintenance intervals of the vehicle manufacturer. **Figure 2.2.**

Figure 2.2

BELL HOUSING GREASE FITTINGS — BOTH SIDES

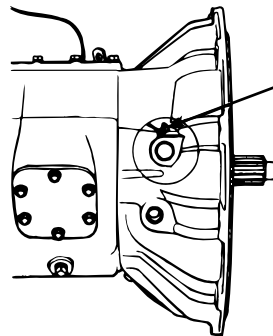

Clutch Linkage

NOTE: Some vehicle manufacturers may use “lubed-for-life” ball joints in the clutch linkage. Refer to the vehicle manufacturer’s instructions.

You must lubricate each pivot point on the linkage according to the vehicle manufacturer’s procedure. **Figure 2.3.** Use the specified lubricant at the recommended interval. Refer to the lubricant specifications and maintenance intervals in the tables below.

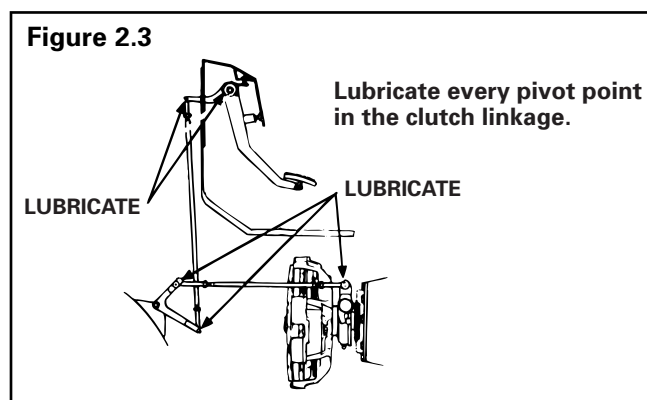

Greasing Interval and Specifications

Component	Greasing Interval	Grease	RICO Specification	NLGI Grade	Grease Description	Outside Temperature
Release Bearing	①	High Temperature Multi-Purpose Wheel Bearing Grease	O-661	3	Lithium Complex	Down to -40°F (-40°C)
Bell Housing	①	②	—	—	—	—
Clutch Linkage	①	②	—	—	—	—

① Use the interval specified by the vehicle manufacturer or the fleet, but make sure the release bearing is greased once per month.

② Use the grease specified by the vehicle manufacturer.

Approved Lubricants

Lubricant	Recommendation
Clutch Bearing Grease	Exxon Unirex N Grade 3 (NLGI Grade No. 3, Lithium Complex)

Section 3 Drivelines

WARNING

To prevent serious eye injury, always wear safe eye protection when you perform vehicle maintenance or service.

Driveline Styles

Industry Name/Description	Series	Type	Lubrication Requirements
Standard or Conventional Driveline	16N 17N 176N 18N	Full Round	Splines and Universal Joints
	16T 17T 176T 18T	Easy Service (1/2 Round)	
Wing Style Greaseable	92N	Wing Style	
Wing Style Permalube	92N	Wing Style	Splines Only
RPL Series (RICO Permalube)	RPL 25 RPL 20	Combination Wing and Full Round	None

RPL Series Permalube™ Driveline Universal Joint, Slip Yoke and Splines

The universal joint, slip yoke and splines are permanently lubricated and sealed and do not require regular lubrication. **Figure 3.1.**

Standard/Conventional Driveline Universal Joint (Figure 3.2)

1. Check the driveline for looseness. If loose, service the driveline as necessary.
2. Clean all grease fittings prior to lubrication.
3. Apply the specified grease at the grease fitting on the universal joint. Apply grease until new grease purges from all four seals.
 - **If new grease does not purge at all the seals:** Loosen the problem bearing cap bolts and regrease until all four cups purge.
 - **If new grease still does not purge:** Replace the universal joint.

Standard/Conventional Driveline Slip Yoke and Splines (Figure 3.2)

1. Check the driveline for looseness. If loose, service the driveline as necessary.
2. Cover the vent hole in the welch plug with a finger.
3. Apply the specified grease at the grease fitting on the slip yoke until the grease purges from the dust seal.

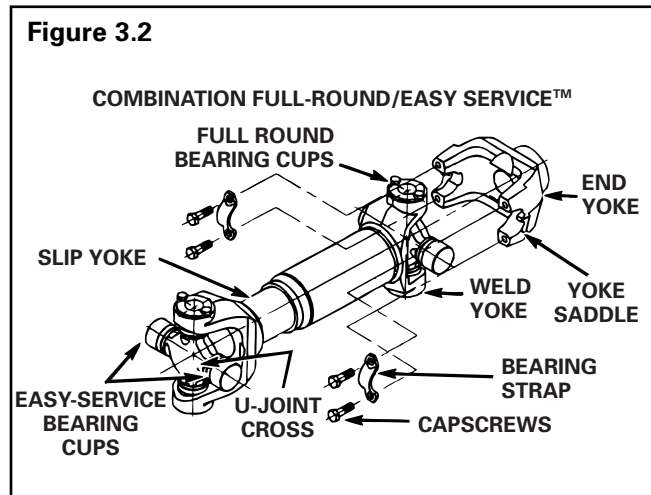
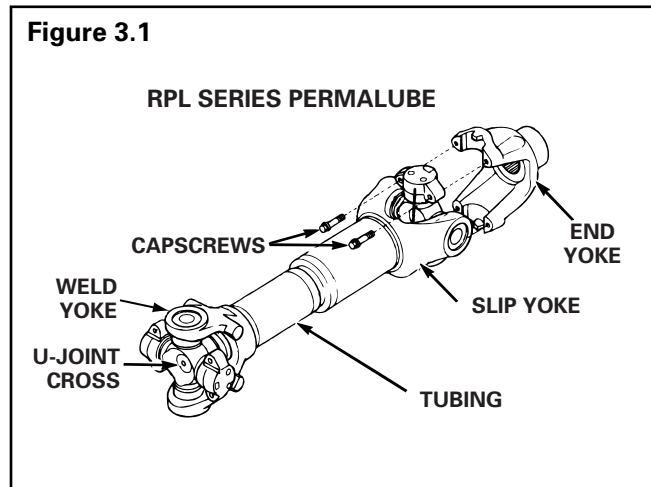

92N Permalube Driveline Universal Joint

The universal joint is permanently lubricated and does not require regular maintenance. **Figure 3.3.**

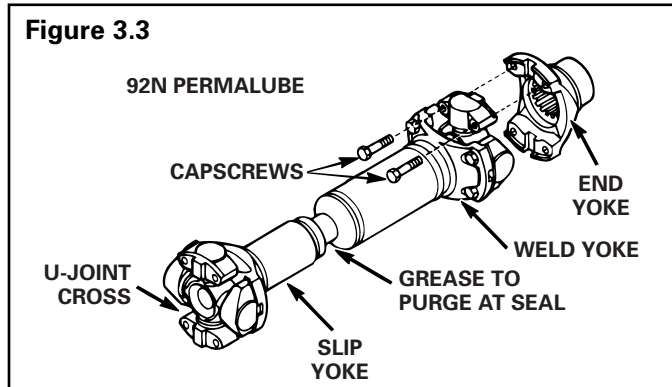

92N Greaseable Driveline Universal Joint

1. Check the driveline for looseness. If loose, service the driveline as necessary.
2. Clean all grease fittings prior to lubrication.
3. Apply the specified grease at the grease fitting on the universal joint. Apply grease until new grease purges from all four seals.
 - **If new grease does not purge at all the seals:** Loosen the problem bearing cap bolts and regrease until all four cups purge.
 - **If new grease still does not purge:** Replace the universal joint.

92N Permalube and Greaseable Driveline Slip Yoke and Splines

WARNING

To prevent serious eye injury, always wear safe eye protection when you perform vehicle maintenance or service.

1. Check the driveline for looseness. If loose, service the driveline as necessary.
2. Clean all grease fittings prior to lubrication.
3. Cover the vent hole in the welch plug with a finger.
4. Apply the specified grease at the grease fitting on the slip yoke until grease purges from the dust seal.

Section 3 Drivelines

Greasing Intervals and Specifications for Standard/Conventional Drivelines

Component	Application	Greasing Interval	Grease	RICO Specification	NLGI Grade	Grease Description	Outside Temperature
Universal Joint, Slip Yoke and Splines	Line Haul	50,000 miles (80 000 km)	Universal Joint Grease	O-634-B	2	Lithium 12-Hydroxy Stearate with Molybdenum Disulfide	②
	Highway	16,000 miles (25 000 km)					
	City	6,500 miles (10 000 km)					
	Construction	①					

- ① The greasing interval depends on the individual operating conditions, speed and loads. To determine the interval, inspect for the presence of grease at all positions until an interval can be determined. Grease the assembly as necessary.
- ② Refer to the grease manufacturer's specifications for the temperature service limits.

Approved Lubricants

Lubricant	Recommendation
Universal Joint Grease	<p>Must meet RICO Specification O-634-B (NLGI Grade No. 2, Lithium 12-Hydroxy Stearate with Molybdenum Disulfide)</p> <p>Amalie All Purpose Grease with Moly-L1-2M</p> <p>Exxon 5160</p> <p>Shell Super Duty Special FF</p> <p>Marathon Maralube Molycode 529</p> <p>Phillips Petroleum Philube MW-EP2 Grease</p> <p>Shell Moly Poly Grease</p> <p>Kendall L424 Grease</p> <p>Amoco Super Chassis Grease</p> <p>Ford Specification M1C-75B or part number PN-C1AZ 19590</p>

WARNING

To prevent serious eye injury, always wear safe eye protection when you perform vehicle maintenance or service.

Front Driving Axles

Magnets and Magnetic Drain Plugs

RICO front driving axles are equipped with magnetic drain plugs that have a minimum pick-up capacity of 1.5 pounds (0.7 kilograms) of low carbon steel.

The magnetic drain plug can be reused if, after cleaning, the plug has a minimum pick-up capacity of 1.5 pounds (0.7 kilograms) of low carbon steel.

RICO recommends replacing the magnetic drain plug each time the oil is changed. Use the correct part. Pipe plugs will leak if used as a drain plug.

Breather

CAUTION

Cover the breather when steam cleaning the housing to prevent water from entering the housing and contaminating the oil. Damage to components can result.

Baffle-type breathers help keep RICO axles free from external moisture and dirt, which can cause premature oil and component failure.

Seals

CAUTION

Always use the correct tools and procedures when replacing seals to ensure correct installation and help prevent seals from leaking.

Seals keep lubricant in and dirt out of a component. When they are worn or damaged, seals leak and produce low lubricant levels which may damage components.

Durable triple lip seals, standard in RICO axles, protect the quality and levels of the lubricant and provide superior performance.

Temperature Indicators

CAUTION

RICO axles can operate above 190°F (88°C) without damage. However, if the oil temperature reaches 250°F (121°C), stop the vehicle immediately and check for the cause of overheating. Damage to components can result.



Many RICO axles have a tapped hole in the housing for the installation of a lubricant temperature indicator that will help reduce the failure of axle parts from overheated oil.

Oil Level

Check and Adjust Oil

1. Make sure the vehicle is parked on a level surface.
2. Remove the fill plug from the axle.
3. The oil level must be even with the bottom of the fill plug hole.
 - If oil flows from the hole when the plug is loosened, the oil level is high. Let the oil drain to the correct level.
 - If the oil level is below the bottom of the fill plug hole, add the specified oil.
4. Install and tighten the fill plug to 35-50 lb-ft (48-67 N•m). 

Drain and Replace Oil

1. Make sure the vehicle is parked on a level surface. Put a large container under the axle.
2. Remove the drain plug from the bottom of the axle. Drain and discard the oil properly.
3. Clean, install and tighten the drain plug to 35-50 lb-ft (48-67 N•m). 
4. Remove the fill plug from the axle.
5. Fill the axle to the bottom of the fill plug hole with the specified oil. Allow enough time for oil to circulate through the axle assembly.
6. Install and tighten the fill plug to 35-50 lb-ft (48-67 N•m). 

Wheel Bearings and Wheel-Ends

Refer to Section 12 for lubrication information on oil- and grease-lubricated wheel bearings and wheel-ends.

Section 4 Front Driving Axles

Knuckle King Pins

With the vehicle weight on the wheel-end, pump grease through the grease (zerk) fittings located on the upper cap or steering arm and lower cap assemblies. Grease should purge through the seals and thrust bearing.

Camshaft Retainer Bushing and Cam Bushing

Pump grease until it purges through the seals.

Drive Axle Shaft Universal Joint

1. Permanently-lubricated (Permalube™) joints do not have a grease fitting provided. Periodic greasing is not required for these parts. For serviceable universal joints (with grease fittings) follow Steps 2 and 3.
2. Clean all grease fittings prior to lubrication.
3. Apply the specified grease at the grease fitting on the universal joint. Apply grease until new grease purges from all the seals.
4. If new grease does not purge at every seal, move the driveline while applying grease at the fittings until new grease purges at every seal. If new grease still does not purge, disassemble the universal joint. Inspect the grease and the components. Service as necessary.

Axle Shaft Spline and Thrust Washer

On axles with greaseable drive flanges, pump grease through the grease (zerk) fitting until it purges at the axle shaft seal. **Figure 4.1.**

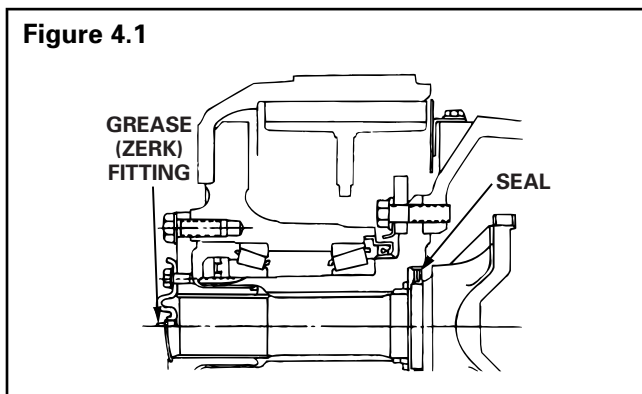

Cross Tube End Assembly

1. Check the cross tube for looseness of more than 0.060-inch (1.52 mm). **Figure 4.2.** If loose, service as necessary.
2. Apply the specified grease at the grease fitting on the cross tube. Apply grease until new grease purges from all the seals.
3. If new grease does not purge at the seals, move the cross tube while applying grease at the fittings until new grease purges from all the seals. If new grease still does not purge, disassemble the cross tube. Inspect the grease and the components. Service as necessary.

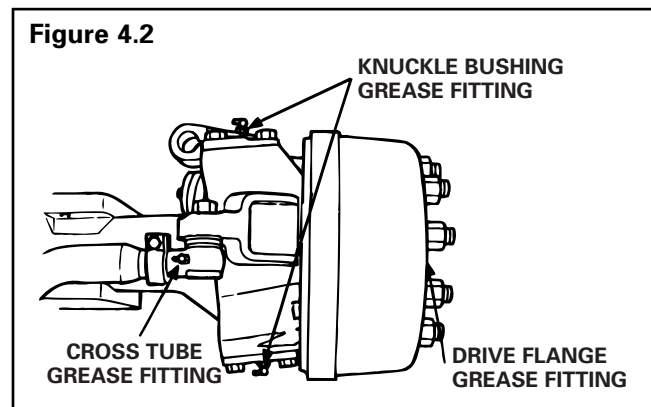

Knuckle Bushing

1. Check the knuckle for looseness. The correct end play is 0.005-0.015-inch (0.127-0.381 mm). **Figure 4.2.** If loose, service as necessary.
2. Clean all grease fittings prior to lubrication.
3. Apply the specified grease at the grease fitting on the knuckle. Apply grease until new grease purges from all the seals. Grease the lower pin cap with the vehicle weight on the wheel-end to ensure that the thrust bearing is completely greased.
4. If new grease does not purge at the seals, move the knuckle while applying grease at the fittings until new grease purges at the seals. If new grease still does not purge, disassemble the knuckle. Inspect the grease and the components. Service as necessary.

Section 4 Front Driving Axles

Front Driving Axle Oil Change Intervals and Specifications*

Operation	On-Highway	Off-Highway
Initial Oil Change	3,000 miles (4800 km)	3,000 miles (4800 km)
Check Oil Level	3,000 miles (4800 km) or 200 operating hours (whichever comes first)	3,000 miles (4800 km)
Petroleum Oil Change	30,000 miles (48 000 km) or 2,000 operating hours (whichever comes first)	30,000 miles (48 000 km) or 2,000 operating hours (whichever comes first)
Synthetic Oil Change	—	—

RICO Specifications	Specification Approval	Oil Description	Outside Temperature			
			F°		C°	
			Min.	Max.	Min.	Max.
O-76A Gear Oil	MIL-PRF-2105-E and SAE J2360	GL-5, SAE 85W/140	10	None	-12	None
O-76D Gear Oil		GL-5, SAE 80W/90	-15	None	-26	None
O-76E Gear Oil		GL-5, SAE 75W/90	-40	None	-40	None
O-76J Gear Oil		GL-5, SAE 75W	-40	35	-40	2
O-76L Gear Oil		GL-5, SAE 75W/140	-40	None	-40	None

* If the front drive axle is the only axle on the vehicle, change the oil every 15,000 miles (24 000 km) or 1,000 hours of operation, whichever comes first.

Front Driving Axle Greasing Intervals and Specifications

Component	Greasing Intervals	Grease	RICO Specification	NLGI Grade	Grease Description	Outside Temperature
Cross Tube End Assemblies, Knuckle Bushings and Drive Flange	3,000 miles (4800 km) or 200 hours of operation, whichever comes first.	Multi-Purpose Grease	O-617-A or O-617-B	1 or 2	Lithium 12-Hydroxy Stearate or Lithium Complex	Refer to the grease manufacturer's specifications for the temperature service limits.
U-Joints		U-Joint Grease	O-634-B	2	Lithium 12-Hydroxy Stearate with Molybdenum Disulfide	

Section 4 Front Driving Axles

Front Driving Axle Oil Capacities

Axle Model	Oil Capacity	
	Pints	Liters
FDS-75	13.0	6.2
FDS-78	13.0	6.2
FDS-85	13.0	6.2
FDS-90	13.0	6.2
FDS-93	13.0	6.2
FDS-750	13.9	6.5
FDS-1600	21.0	9.9
FDS-1800	28.0	13.2
FDS-1805	28.0	13.2
FDS-1807	28.0	13.2
FDS-1808	28.0	13.2
FDS-2100	28.0	13.2
FDS-2101	28.0	13.2
FDS-2102	43.0	20.3
FDS-2107	43.0	20.3
FDS-2110	43.0	20.3
FDS-2111	43.0	20.3
FDS-2117	43.0	20.3
RF-7-106*	14.0	6.6
RF-9-106*	14.0	6.6
RF-12-125*	15.3	7.2
RF-16-145*	36.4	17.2
RF-21-155*	27.9	13.2
RF-21-156*	27.9	13.2
RF-21-160*	43.7	20.7
RF-21-355*	28.0	13.2
RF-23-180*	39.3	18.6

* Oil capacities are for standard track axles that have been measured at various common drive pinion angles. The quantities listed include enough oil for both wheel-ends. These oil capacities will change if the track or the drive pinion angle is different.

WARNING

To prevent serious eye injury, always wear safe eye protection when you perform vehicle maintenance or service.

King Pins

Conventional Front Axles

NOTE: This procedure applies to 901, 903, 910, 935 and 970 front conventional axles. Refer to the identification tag on the front of the axle beam.

On conventional front axles, the grease fittings are on the side of the knuckle.

WARNING

Park the vehicle on a level surface. Block the wheels to prevent the vehicle from moving. Support the vehicle with safety stands. Do not work under a vehicle supported only by jacks. Jacks can slip or fall over and cause serious personal injury.

1. Lift the vehicle so that the tires are off the ground. The tires should always be off the ground when the king pins are lubricated. Support the vehicle with safety stands. Put blocks in front and in back of the rear wheels to keep the vehicle from moving.
2. Clean all grease fittings prior to lubrication.
3. Lubricate the king pins through the top and the bottom grease fittings on the side of the knuckle. **Figure 5.1.**
4. Apply lubricant to the top fitting until new lubricant purges from between the upper shim pack and thrust bearing seal.
5. Lower the vehicle so that the wheels touch the ground.
6. Apply lubricant to the bottom fitting until new lubricant purges and fills the thrust bearing.

Figure 5.1

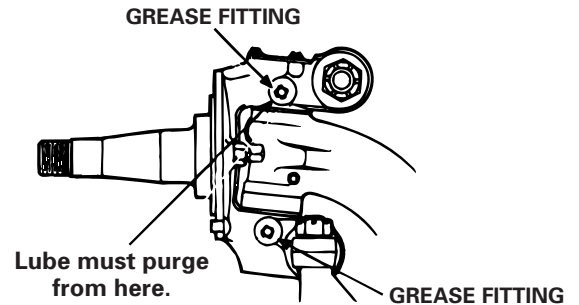

Sealed and Easy Steer™ Front Axles

NOTE: This procedure applies to 911, 921, 931, 932, 933, 934, 941, 942, 943, 944, 951, 952, 961, 963, 971 and 975 Series sealed front axles. Refer to the identification tag on the front of the axle beam.

On sealed and Easy Steer front axles, the grease fittings are on the top and bottom king pin caps of the knuckle.

1. Make sure the tires touch the ground. Do not elevate the vehicle.
2. Clean all grease fittings prior to lubrication.
3. Lubricate the king pins through the grease fittings on the top and bottom of the knuckle. **Figure 5.2.**
4. Apply lubricant until new lubricant purges from the thrust bearing seal and the upper shim pack.

Figure 5.2

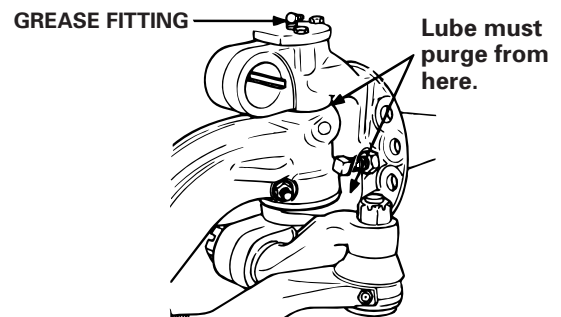

Section 5 Front Non-Driving Axles

Easy Steer Plus™ Front Axles

NOTE: Removal of the long-life bearings, seals and lubricant from the hub assembly will void the warranty.

Meritor's Easy Steer Plus front axle features a permanently-sealed and lubricated truck hub unit designed to help reduce wheel-end maintenance. Refer to Maintenance Manual MM-99120 for service procedures.

CAUTION

A unitized hub is permanently sealed and lubricated as an assembly. Do not attempt to remove the hub bearings, seals and lubricant. You cannot service or reinstall these components into a unitized hub assembly. Damage to components can result.

NOTE: On Easy Steer Plus front axles, the grease fittings are located on the top and bottom king pin caps.

1. Be certain that the tires touch the ground. Do not raise the vehicle.
2. Clean all grease fittings prior to lubrication.
3. Lubricate the king pins through the grease fittings on the top and bottom of the knuckle. **Figure 5.3.**
4. Force lubricant into upper and lower king pin grease fitting caps until new lubricant flows from between the following two areas:
 - Upper axle beam end and the knuckle. **Figure 5.3.**
 - Lower axle beam end and the knuckle. **Figure 5.3.**

Figure 5.3

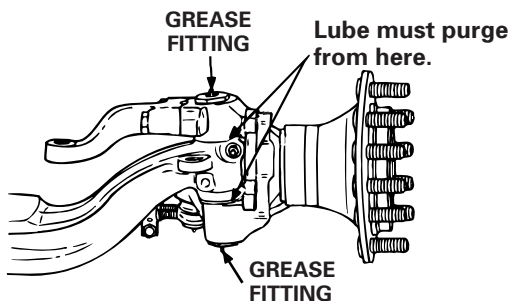

Ball Studs on the Steering Arm, Tie Rod Arm Ends and Drag Link

Conventional Front Axles, Easy Steer Front Axles, Easy Steer Plus Front Axles

1. The tires must touch the ground. Do not raise the vehicle.
2. Clean and remove oil grease fittings prior to lubrication.
3. Apply lubricant at each grease fitting until new lubricant flows from the boot. **Figures 5.4 and 5.5.**

Figure 5.4

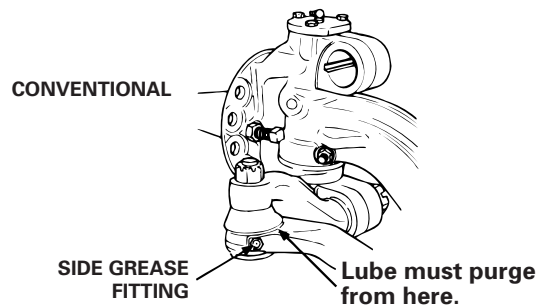
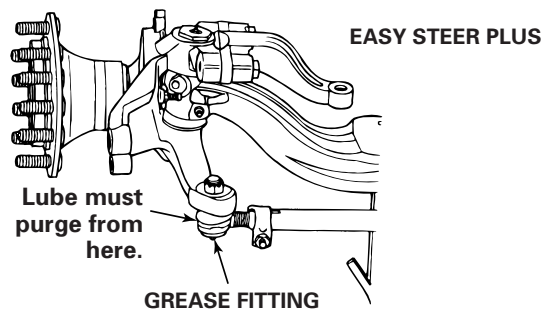

Figure 5.5



Wheel Bearings and Wheel-Ends

Conventional Front Axles, Easy Steer Front Axles, Easy Steer Plus Front Axles

Refer to Section 12 for oil and grease lubrication information.

Section 5 Front Non-Driving Axles

Conventional Front Non-Driving Axle Greasing Intervals and Specifications

Applies to all FF and FD Series axle models used in linehaul and city delivery vocations and including FD-931, FD-933 and FD-961 applications.

Component	Greasing Intervals	Grease	RICO Specification	NLGI Grade	Grease Description	Outside Temperature
King Pins and Bushings	100,000 miles (160 000 km) or once a year, whichever comes first.	Multi-Purpose Grease	O-617-A	1	Lithium 12-Hydroxy Stearate or Lithium Complex	Refer to the grease manufacturer's specifications for the temperature service limits.
Ball Studs on Steering Arm, Tie Rod Arm Ends and Drag Link*			O-617-B	2		

* Applies to ball studs on conventional and Easy Steer front axles. For sealed axles, inspect the boot on the ball stud every 96,000 miles (154 000 km) for wear and damage. Service as necessary.

Conventional Front Non-Driving Axle Greasing Intervals and Specifications

Applies to all FF Series axle model used in other vocations (not linehaul) and including all FC-901, FC-903, FC-921, FC-941, FD-901, FE-970, FG-931, FG-933, FG-941, FG-943, FL-931, FL-941, FL-951, FU-910 and FU-935 applications.

Component	Greasing Intervals	Grease	RICO Specification	NLGI Grade	Grease Description	Outside Temperature
King Pins and Bushings	50,000 miles (80 000 km) or once a year, whichever comes first.	Multi-Purpose Grease	O-617-A	1	Lithium 12-Hydroxy Stearate or Lithium Complex	Refer to the grease manufacturer's specifications for the temperature service limits.
Ball Studs on Steering Arm, Tie Rod Arm Ends and Drag Link*			O-617-B	2		

* Applies to ball studs on conventional and Easy Steer axles. For sealed axles, inspect the boot on the ball stud every 96,000 miles (154 000 km) for wear and damage. Service as necessary.

Easy Steer Plus Front Non-Driving Axle Greasing Intervals and Specifications

Applies to FF 981, FF 982, FF 983, FF 984 and FF 985 front non-driving steering axles in all vocations.

Component	Greasing Intervals	Grease	RICO Specification	NLGI Grade	Grease Description
King Pins and Bushings	100,000 miles (160 000 km) or once a year, whichever comes first.	Multi-Purpose Grease	O-617-A	1	Lithium 12-Hydroxy Stearate or Lithium Complex
Ball Studs on Steering Arm, Tie Rod Arm Ends and Drag Link*			O-617-B	2	
Truck Hub Unit	No Lube to Hub	Unit sealed for life of component	NONE	NONE	DO NOT LUBRICATE

* Applies to ball studs on conventional and Easy Steer axles. For sealed axles, inspect the boot on the ball stud every 96,000 miles (154 000 km) for wear and damage. Service as necessary.

Section 6

On-Highway Brakes

Q Plus™ LX500 Cam Brake Package with the Extended Lube Feature

Available for On-Highway Linehaul and All Other Applications

NOTE: You must continue to observe all other brake preventive maintenance schedules and procedures for Q Plus LX500 and MX500 cam brakes with factory-installed RICO automatic slack adjusters. Refer to Maintenance Manual MM-96173, *Q Plus LX500 Cam Brakes*, and Maintenance Manual 4B, *Automatic Slack Adjuster*.

Meritor's new Q Plus LX500 cam brake package with the Extended Lube feature is available for on-highway linehaul and all other applications and includes:

- Q Plus LX500 cam brakes.
- RICO factory-installed automatic slack adjusters.
- Extended Lube Feature: For on-highway linehaul applications, the Q Plus LX500 camshaft and slack adjusters do not require lubrication and reline for 3 years or 500,000 miles (800 000 km), whichever comes first. For all other applications, the lubrication interval is one year, regardless of mileage.

Q Plus™ MX500 Extended Maintenance Package Option

Available for On-Highway Linehaul Applications Only

Meritor's new Q Plus MX500 cam brake is available for on-highway linehaul applications only and includes:

- Extended Maintenance Package: Proprietary friction material on 5-inch wider shoes for front axles and 8-inch wider shoes for rear axles for more wearable volume than Q Plus LX500 brakes.
- Extended Lube Feature: The Q Plus MX500 camshaft and slack adjusters do not require lubrication and reline for 3 years or 500,000 miles (800 000 km), whichever comes first.
- RICO factory-installed automatic slack adjusters.

Identifying Q Plus™ LX500 and MX500 Cam Brakes

NOTE: Do not remove the identification tag from the camshaft bracket during the extended maintenance period.

You can identify Q Plus LX500 and MX500 cam brakes by checking the identification tags affixed to the brake.

1. A brake shoe tag identifies the brakes as Q Plus brakes.
2. An additional identification tag imprinted with "SEE RICO MAINTENANCE MANUAL MM-96173 FOR LUBE INFO," which is affixed to the brake chamber bracket over the top of the plugged grease hole, identifies the brake as a Q Plus LX500 or MX500 brake.
3. Q Plus LX500 and MX500 brakes and automatic slack adjusters do not have grease fittings.

Lubricating the Q Plus™ LX500 and MX500 Cam Brakes and Automatic Slack Adjusters After Specified Mileage or Time Intervals

1. Remove the identification tag from the chamber bracket housing.
2. Remove grease plugs from both the chamber bracket and the automatic slack adjuster.
3. Install grease fittings and lubricate the brake assembly through the grease fitting in the bracket with RICO-approved synthetic grease O-695 until new grease flows from the inboard seal.
4. Lubricate the automatic slack adjuster through the grease fitting until new grease flows out of the pull pawl or camshaft seal.
5. Replace the fittings with new grease plugs and cover the bracket plug with a new identification tag.

Camshaft Bushings

 **WARNING**

To prevent serious eye injury, always wear safe eye protection when you perform vehicle maintenance or service.

 **CAUTION**

When grease flows from the seal near the cam head, replace the seal. Remove any grease from the cam head, rollers and linings. Grease on the linings can increase stopping distances.

If grease flows from the seal near the cam head, replace the seal. Remove any grease or oil from the cam head, rollers and linings. Always replace contaminated linings. Grease on the linings can increase stopping distances. Serious personal injury and damage to components can result.

Q Plus™, Cast Plus™, Q Series, P Series and T Series Cam Brakes

RICO cam brakes are air-actuated, cam-operated, two-shoe brakes with each shoe mounted on a separate anchor pin. The brakes are available with automatic or manual slack adjusters and can be assembled with spring brakes.

Wedge Brake Grease Specifications

Component	RICO Specification	NLGI Grade	Grease Description	Outside Temperature
All Actuating Components, All Areas Where Shoes Contact Spider, Anchor Plungers, Adjusting Bolts or Retainer Hardware	O-616-A	1	Clay Base	Down to -40°F (-40°C)
	O-645	2	Synthetic Oil, Clay Base	Down to -65°F (-54°C)

Conventional Automatic Slack Adjuster Grease Specifications

Component	RICO Specification	NLGI Grade	Grease Description	Outside Temperature
Automatic Slack Adjuster	O-616-A	1	Clay Base	Down to -40°F (-40°C)
	O-692	1 and 2	Lithium Base	Down to -40°F (-40°C)
	O-645	2	Synthetic Oil, Clay Base	Down to -65°F (-54°C)
Clevis Pins	Any of Above	Refer to Above	Refer to Above	Refer to Above
	O-637*	1-1/2	Calcium Base	Refer to the grease manufacturer's specifications for the temperature service limits.
	O-641	—	Anti-Seize	

* Do not mix O-637 calcium-base, corrosion-control grease with other greases.

Section 6 On-Highway Brakes

Manual Slack Adjuster Grease Specifications

Component	RICO Specification	NLGI Grade	Grease Description	Outside Temperature
Manual Slack Adjuster	O-616-A	1	Clay Base	Down to -40°F (-40°C)
	O-617-A or O-617-B	1 2	Lithium 12-Hydroxy Stearate or Lithium Complex	Refer to the grease manufacturer's specifications for the temperature service limits.
	O-645	2	Synthetic Oil, Clay Base	Down to -65°F (-54°C)
	O-692	1 and 2	Lithium Base	Down to -40°F (-40°C)
Clevis Pins	Any of Above	Refer to Above	Refer to Above	Refer to Above
	O-637*	1-1/2	Calcium Base	Refer to the grease manufacturer's specifications for the temperature service limits.
	O-641	—	Anti-Seize	

* Do not mix O-637 calcium-base, corrosion-control grease with other greases.

Cam Brake Grease Specifications

Components	RICO Specification	NLGI Grade	Grease Description	Outside Temperature
Retainer Clips Anchor Pins Roller (Journals Only) Camshaft Bushings When the brake is disassembled, or when necessary, lubricate the anchor pins and rollers where they touch the brake shoes. Do not allow grease to come in contact with the part of the cam roller that touches the cam head.	O-616-A	1	Clay Base	Down to -40°F (-40°C)
	O-617-A or O-617-B	1 2	Lithium 12-Hydroxy Stearate or Lithium Complex	Refer to the grease manufacturer's specifications for the temperature service limits.
	O-645	2	Synthetic Oil, Clay Base	Down to -65°F (-54°C)
	O-692	1 and 2	Lithium Base	Down to -40°F (-40°C)
Camshaft Splines	Any of Above	Refer to Above	Refer to Above	Refer to Above
	O-637*	1-1/2	Calcium Base	Refer to the grease manufacturer's specifications for the temperature service limits.
	O-641	—	Anti-Seize	

* Do not mix O-637 calcium-base, corrosion-control grease with other greases.

Air Disc Brake (1540, 1560, 1760) Grease Specifications

Component	RICO Specification	NLGI Grade	Grease Description	Outside Temperature
Caliper ①	O-616-A	1	Clay Base	Down to -40°F (-40°C)
	O-645	2	Synthetic Oil, Clay Base	Down to -65°F (-54°C)
Slide Pin Retainers	O-637 ②	1-1/2	Calcium Base	Refer to the grease manufacturer's specifications for the temperature service limits.
	O-641	—	Anti-Seize	
Powershaft Splines	Any of Above	Refer to Above	Refer to Above	Refer to Above

① The grease used inside the caliper must be non-melting and also allow proper brake function at the cold temperatures listed.

② Do not mix O-637 calcium-base, corrosion-control grease with other greases.

Section 6 On-Highway Brakes

Q Plus LX500 and MX500 Greasing Service Intervals and Specifications

On-Highway Linehaul Applications	3 years or 50,000 miles (80 000 km), whichever comes first
All Other Applications	One year, regardless of mileage

Component	RICO Specification	NLGI Grade	Grease Description	Outside Temperature
Camshaft Splines and Clevis Pins	O-695	2	Synthetic Polyurea	-40°F (-40°C)
Anchor Pins When the brake is disassembled, or when necessary, lubricate the anchor pins where they touch the brake shoes.	O-617-A	1	Lithium 12-Hydroxy Stearate or Lithium Complex	Refer to the grease manufacturer's specifications for the temperature service limits.
	O-617-B	2		
	O-645	2	Synthetic Oil, Clay Base	Down to -65°F (-54°C)
	O-692	1 and 2	Lithium Base	Down to -40°F (-40°C)
Shoe Rollers When the brake is disassembled, or when necessary, lubricate the rollers where they touch the brake shoes. DO NOT get grease on the part of the roller that touches the cam head.	O-617-A	1	Lithium 12-Hydroxy Stearate or Lithium Complex	Refer to the grease manufacturer's specifications for the temperature service limits.
	O-617-B	2		
Automatic Slack Adjusters	O-695	2	Synthetic Polyurea	-40°F (-40°C)

Approved Greases

Lubricant	Recommendation
O-616-A	Shell Darina Grease No. 1 Texaco Thermatex EP-1 Texaco Hytherm EP-1 Aralub 3837
O-617-A O-617-B	Multi-Purpose Lithium Chassis Grease
O-637*	Witco Chemical Corp. SA-824946
O-641	Never-Seez Anti-Seize
O-645	Mobilgrease 28 (Military) Mobiltemp SHC 32 (Industrial) Aerospace Lubricants Inc. Tribolube 12-Grade 1
O-692	Amoco Super Permalube #2 Citgo Premium Lithium EP-2 #2 Exxon Ronex MP-2 #2 Kendall L-427 Super Blu #2 Mobilith AW-1 #1 Sohio Factran EP-2 #2
O-695	EVO-LUBE TEK-615

* Do not mix O-637 calcium-base, corrosion-control grease with other greases.

Section 7

Planetary Drive Axles

WARNING

To prevent serious eye injury, always wear safe eye protection when you perform vehicle maintenance or service.

Refer to Section 1 for recommended oil drain conditions based on used axle oil analysis.

Magnets and Magnetic Drain Plugs

Planetary axles are equipped with magnetic drain plugs that have a minimum pick-up capacity of 20 ounces (0.57 kilograms) of low carbon steel. The drain plug must be checked for metal particles at every oil change interval.

RICO recommends replacing the magnetic drain plug each time the oil is changed. Use the correct part. Pipe plugs will leak if used as a drain plug.

The magnetic drain plug can be reused if, after cleaning, the plug has a minimum pick-up capacity of 20 ounces (0.57 kilograms) of low carbon steel.

Breather

CAUTION

Cover the breather when steam cleaning the housing. If the breather is not covered, water can enter the housing and contaminate the oil. Damage to components will result.

Breathers release pressure and vacuum condensation to help maximize oil and component life.

Seals

CAUTION

Always use the correct tools and procedures when replacing seals to prevent incorrect installation and leaking seals.

Seals keep lubricant in and dirt out of a component. When they are worn or damaged, seals leak and produce damaging low lubricant levels that will damage components.

Temperature Indicators

CAUTION

RICO axles can operate above 190°F (88°C) without damage. However, if the oil temperature reaches 250°F (121°C), stop the vehicle immediately and check for the cause of overheating to prevent damage to components.

Check and Adjust the Oil Level

For complete fill procedures for wet disc brakes, refer to Maintenance Manual 4L, *Wet Disc Brakes*.

NOTE: Fill and drain plugs are located in the axle housing bowl and the wheel ends. Most axles have a common oil level. All steering axles and some rigid axles have separate oil levels in each wheel end and the axle housing bowl.

1. The vehicle must be on a level surface.
2. For an axle with a common oil level that has drain and fill plugs only in the axle assembly, proceed to Step 4.
3. Rotate the wheels so that the oil level lines on the wheel ends are parallel to the ground.
4. Clean the areas around the fill/level plugs. Remove the plugs from the wheel end and the axle housing bowl. **Figure 7.1.** The oil level must be even with the bottom of the fill/level plug.
 - **If oil flows from the hole when you loosen the plug:** The oil level is high. Drain the oil to the correct level.
 - **If the oil level is below the bottom of fill/level plug hole:** Add the specified oil according to one of the following procedures:
 - A. **For axles with separate oil levels in the wheel ends and the axle housing bowl:** Fill each area with specified oil to the bottom of the fill plug holes.
 - B. **For axles with a common oil level:** Fill the axle with specified oil at each wheel end and axle housing bowl to the bottom of the fill plug holes. Wait and allow the oil to flow through the axle. Check the oil level again and fill to the correct level, if necessary.

Section 7

Planetary Drive Axles

5. Install and tighten the fill/level plugs to the correct torque specification.

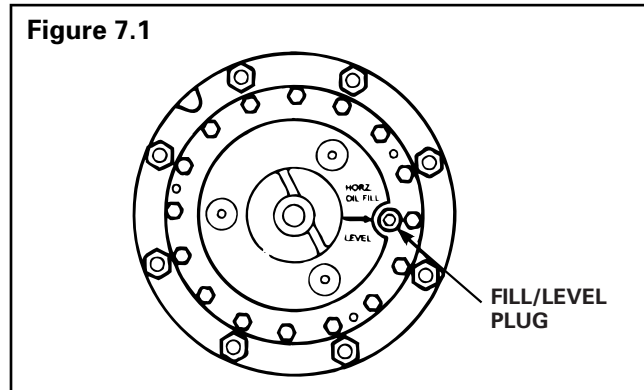

Drain and Replace the Oil

NOTE: Fill and drain plugs are located in the axle housing bowl and the wheel ends. Most axles have a common oil level. All steering axles and some rigid axles have separate oil levels in each wheel end and the axle housing bowl.

WARNING

Park the vehicle on a level surface. Block the wheels to prevent the vehicle from moving. Support the vehicle with safety stands. Do not work under a vehicle supported only by jacks. Jacks can slip and fall over. Serious personal injury can result.

1. Make sure the vehicle is on a level surface. Put large containers under the axle and wheel ends.
2. Raise the vehicle so that the wheels are off the ground. Support the vehicle with safety stands.
3. Rotate the wheels so that the “fill/level” plugs in the wheel ends are toward the ground.
4. Remove the drain plugs from the wheel ends. Drain the oil. Follow correct procedures to discard the oil. Clean the drain plug.
5. Install and tighten the drain plug in the axle housing bowl and the wheel ends to 35-50 lb-ft (48-67 N•m). 
6. Rotate the wheels so that the “oil level lines” on the wheel ends are parallel to the ground. Lower the vehicle.

7. Clean the area around the fill/level plug. Remove the fill/level plug from the wheel ends and the axle housing bowl.
8. Add the specified oil until the oil level is even with the bottom of the fill/level hole.
 - **For axles with separate oil levels in the wheel ends and the axle housing bowl:** Fill each area with specified oil to the bottom of the fill plug holes.
 - **For axles with a common oil level:** Fill the axle with specified oil at each wheel end and axle housing bowl to the bottom of the fill plug holes. Wait and allow the oil to flow through the axle. Check the oil level again and fill to the correct level, if necessary.
9. Install and tighten the fill/level plugs to the correct torque specification.

Section 7

Planetary Drive Axles

Planetary Drive Axle Oil Change Intervals and Specifications

Operation	On-Highway*	Off-Highway*
Initial Oil Change	2,500 miles (4000 km)	100 operating hours*
Check Oil Level	5,000 miles (8000 km)	250 operating hours*
Petroleum Oil Change	25,000 miles (40 000 km) or once a year (whichever comes first)	1,500 operating hours or twice a year (whichever comes first)*
Synthetic Oil or Semi-Synthetic Oil Change	Refer to Technical Publication TP-9303	3,000 operating hours or once a year (whichever comes first)

RICO Specifications	Specification Approval	Oil Description	Outside Temperature			
			°F		°C	
			Min.	Max.	Min.	Max.
O-76A Gear Oil	MIL-PRF-2105-E and SAE J2360	GL-5, SAE 85W/140	10	None	-12	None
O-76D Gear Oil		GL-5, SAE 80W/90	-15	None	-26	None
O-76E Gear Oil		GL-5, SAE 75W/90	-40	None	-40	None
O-76L Gear Oil		GL-5, SAE 75W/140	-40	None	-40	None
O-76M Gear Oil		GL-5, SAE 75W/140	-40	None	-40	None
O-76N Gear Oil		GL-5, SAE 75W/140	-40	None	-40	None

* The interval depends on the individual operating conditions, speeds and loads. Severe operating conditions may require more frequent intervals.

Planetary Drive Axle Oil Capacities

Axle Model	Axle Housing Approximate Oil Capacity*		Wheel Ends Approximate Oil Capacity*	
	Pints	Liters	Pints	Liters
PR-53	33.0	15.6	3.0	1.4
PR-60	27.0	12.8	3.0	1.4
PR-100	22.0	10.4	3.5	1.6
PR-108	29.0	13.7	7.0	3.3
PR-111	27.0	12.8	4.6	2.2
PR-112	44.0	20.8	6.0	2.8
PR-145	32.0	15.1	5.0	2.4
PR-150	29.0	13.7	5.0	2.0
PR-151	30.0	14.2	8.0	3.8
PR-153	31.0	14.7	7.5	3.6
PR-200	40.0	18.9	6.0	2.8
PR-205	46.0	21.8	7.0	3.3
PR-207	45.0	21.3	6.0	2.8
PR-208	43.0	20.3	8.0	3.8
PR-209	56.0	26.4	5.0	2.4
PR-251	42.0	19.9	12.0	5.7

Axle Model	Axle Housing Approximate Oil Capacity*		Wheel Ends Approximate Oil Capacity*	
	Pints	Liters	Pints	Liters
PR-253	39.0	18.5	13.0	6.20
PR-256	44.0	20.8	18.0	8.50
PR-270	44.0	20.8	18.0	8.50
PR-350	28.0	13.2	14.0	16.60
PR-400	32.0	15.1	16.0	7.60
PR-500	56.0	26.5	28.0	13.20
PR-501	64.0	30.3	28.0	13.20
PR-502	62.0	29.3	31.0	14.70
PR-700	64.0	30.3	30.0	14.19
PRC-184	32.0	15.1	4.0	1.80
PRC-264	16.0	7.5	4.0	1.80
PRC-755	32.0	15.1	10.0	4.70
PRC-864	30.0	14.1	6.0	2.80
PRC-867	48.0	22.7	10.0	4.70
PRC-1925	32.0	15.1	16.0	7.57
PRC-3795	28.0	13.2	14.0	6.62

* Due to varied planetary drive axle specifications, these fill quantities are for reference only.

Section 7 Planetary Drive Axles

Planetary Drive Axle Oil Capacities

Axle Model	Axle Housing Approximate Oil Capacity*		Wheel Ends Approximate Oil Capacity*	
	Pints	Liters	Pints	Liters
PRC-3796	48.0	22.7	28.0	13.20
PRC-3805	58.0	27.4	22.0	10.40
PRC-4805	60.0	28.3	31.0	14.60
PRC-5324	80.0	37.8	24.0	11.30
PRC-5334	80.0	37.8	24.0	11.30
PRC-7314	72.0	34.0	24.0	11.30
PRLC-344	44.0	20.8	6.0	2.84
PRLC-614	29.0	13.7	7.0	3.31
PRLC-675	56.0	26.5	5.0	2.37
PRLC-823	44.0	20.8	18.0	8.51
PRLC-1756	39.0	18.5	13.0	6.15
PRLC-1757	39.0	18.5	13.0	6.15
PRLC-1925	72.0	34.0	12.0	5.60
PRLM-855	28.0	13.2	8.0	3.70
PRM-672	29.0	13.7	5.0	2.37
PRM-673	29.0	13.7	5.0	2.37
PRM-676	46.0	21.8	7.0	3.31
PRM-677	46.0	21.8	7.0	3.31
PRM-1314	44.0	20.8	18.0	8.51
PRM-1315	44.0	20.8	18.0	8.51
PRM-1615	44.0	20.8	18.0	8.51
PRM-1756	43.0	20.3	13.0	6.15
PRM-1757	43.0	20.3	13.0	6.15
PRTA-134	14.0	6.6	4.0	1.80
PRTC-203	19.0	8.9	6.0	2.80
PRS-16	27.0	12.8	3.0	1.42
PS-100	20.0	9.5	3.5	1.66
PS-150	22.0	10.4	5.0	2.37
PS-200	38.0	18.0	6.0	2.84
PS-260	44.0	20.8	8.0	3.25
PS-270	44.0	20.8	8.0	3.78
PS-310	36.0	17.0	14.0	6.62
PS-500	58.0	27.4	29.0	13.72
PSC-204	29.0	13.7	6.0	2.80
PSC-593	28.0	13.0	4.0	1.89
PSC-594	28.0	13.2	4.0	1.89
PSC-1615	40.0	18.9	8.0	3.78
PSC-1617	40.0	18.9	8.0	3.78

Axle Model	Axle Housing Approximate Oil Capacity*		Wheel Ends Approximate Oil Capacity*	
	Pints	Liters	Pints	Liters
PSC-1875	56.0	26.4	20.0	9.40
PSC-4564	58.0	27.4	29.0	13.72
PSM-826	42.0	19.9	6.0	2.80
PSM-1044	44.0	20.8	6.0	2.80
PSM-1045	44.0	20.8	6.0	2.80
PSM-1614	44.0	20.8	8.0	3.70
PSTM-824	28.0	13.2	6.0	2.80
EPRC-1356				
Forward	32.0	15.1	14.0	6.60
Middle	32.0	15.1	14.0	6.60
Rear	32.0	15.1	14.0	6.60
SPRC-1356				
85" Track	32.0	15.1	14.0	6.60
90" Track	33.5	15.9	14.0	6.60
100" Track	36.0	17.0	14.0	6.60
SPRC-1357				
Forward	36.0	17.0	14.0	6.60
Rear	36.0	17.0	14.0	6.60
SPRC-1357				
85" Track	32.0	15.1	14.0	6.60
90" Track	33.5	15.9	14.0	6.60
100" Track	36.0	17.0	14.0	6.60
SPRC-1735				
85" Track	32.0	15.1	15.0	7.10
90" Track	33.5	15.9	15.0	7.10
100" Track	36.0	17.0	15.0	7.10
SPRC-1736				
Forward	36.0	17.0	15.0	7.10
Rear	36.0	17.0	15.0	7.10
SPRC-1736				
85" Track	32.0	15.1	15.0	7.10
90" Track	33.5	15.9	15.0	7.10
100" Track	36.0	17.0	15.0	7.10
SPRC-1926	32.0	15.1	16.0	7.60
SPRC-4806	64.0-72.0	31.0-34.0	32.0	15.10

* Due to varied planetary drive axle specifications, these fill quantities are for reference only.

Section 8 Rear Drive Axles

WARNING

To prevent serious eye injury, always wear safe eye protection when you perform vehicle maintenance or service.

CAUTION

You must fill RICO axles with RICO-specified lubricants only. Do not fill an axle with non-approved lubricants, which will void Meritor's warranty. Damage to axle components also can result.

To avoid axle component damage, fill RICO axles with approved lubricants only. Using non-approved lubricants also will void Meritor's warranty.

NOTE: For information on lubricant suppliers, call ArvinMeritor's Customer Service Center at 800-535-5560 and order technical bulletin TP-9539. This bulletin is also available from the Technical Library section on ArvinMeritor's web site at www.arvinmeritor.com. Click Products & Services/Tech Library Icon/HVS Publications/Technical Bulletins/Axles.

NOTE: Refer to Section 12 for information on wheel bearings and wheel-ends.

Magnets and Magnetic Drain Plugs

NOTE: RICO recommends replacing the magnetic drain plug each time the oil is changed. Use the correct part. Pipe plugs will leak if used as a drain plug.

Although RICO axles are normally equipped with magnetic plugs having a minimum pick-up capacity of 1.5 pounds (0.7 kilograms) of low carbon steel, RICO Advanced Lube axles have stronger magnetic "cleansing" features.

These axles are equipped with strong five-pound (2.2 kilograms) pull magnets, and high grade magnetic fill and drain plugs that collect damaging particles at the bottom of the axle housing.

Tandem axles have four magnets in each housing and high grade magnetic fill and drain plugs. Single axles have six magnets in each housing and high grade magnetic drain and fill plugs.

Check the drain plug for metal particles every 100,000 miles (160 000 kilometers). You can reuse a magnetic drain plug if the plug has a minimum pick-up capacity of 1.5 pounds (0.7 kilograms) of low carbon steel after cleaning.

Breather

CAUTION

Cover the breather when steam cleaning the housing. If the breather is not covered, water enters the housing and contaminates the oil. Damage to components can result.

Baffle-type breathers release pressure and vacuum condensation to minimize premature oil and component failure.

Seals

CAUTION

Always use the correct tools and procedures when replacing seals to prevent incorrect installation, leaking seals and damage to components.

Seals keep lubricant in and dirt out of a component. When they are worn or damaged, seals leak and produce damaging low lubricant levels.

Durable triple-lip pinion seals, standard in RICO axles, protect the quality and levels of the lubricant and provide superior performance.

RICO Advanced Lube axles have triple-lip seals designed to work with current and future lubricants.

Temperature Indicators



RICO axles can operate above 190°F (88°C) without damage. However, if oil the temperature reaches 250°F (121°C), stop the vehicle immediately and check for the cause of overheating. Damage to components can result.

Some RICO axles may have a tapped hole in the housing to install a temperature indicator. A temperature indicator monitors oil temperature and helps to maximize component life, which can be shortened by high oil temperatures that result from severe operating conditions, or unequally inflated and mismatched tires.

Advanced Lube Axles

Advanced Lube axles require different drain intervals than other axles. Refer to the Oil Change Intervals and Axle Oil Specifications tables in this section.

The vehicle manufacturer may attach a tag at the axle fill hole or on the inside of the door to identify an Advanced Lube axle. The tag specifies that the axle is filled with semi-synthetic or full-synthetic gear oil.

For RICO R-170 Axles Equipped With Traction Equalizer®

Meritor's R-170 axles with Traction Equalizer normally operate with either standard petroleum, semi-synthetic or full-synthetic oils.

When to Use Limited Slip Friction Modifiers

Occasionally the Traction Equalizer will "slip" or "stick." When this happens, you will hear intervals of shrill noises when the vehicle operates at low speed or when the vehicle makes sharp turns. You can correct this condition by adding limited slip friction modifiers.

NOTE: Limited slip friction modifiers usually deteriorate more quickly than extreme pressure (EP) additives. Shorten the lubricant change schedule if you add a friction modifier.

- **At the initial lubricant change interval for an R-170 equipped with Traction Equalizer:** Replace the factory-installed lubricant with an approved lubricant and one of the additives specified in the table below.
- **After the initial change interval:** Change the lubricant and the additive at or before 50,000 miles (80 000 km).

Specifications

For all GL-5 oils (petroleum oil or synthetic), add one of the following limited slip friction modifiers specified in the table below.

Manufacturer	Specification
DSL-178	Guardsman Products
Equa-Torque #2411 and #2414	Sta-Lube Corporation
Lubrizol # 6178	Lubrizol Corporation

Quantities for R-170 Axles With and Without Traction Equalizer

WITH Traction Equalizer	WITHOUT Traction Equalizer
40 pints oil (18.9 liters) + 3 Pints additive (1.4 liters)	43 pints oil (20.3 liters)

Oil Level

Fill Plug Locations

1. If the fill plug is only in the axle-housing bowl, use that fill plug. Do not use the temperature sending unit hole. **Figure 8.1.**
2. If the drive pin angle is seven degrees or less, use the fill plug in the differential carrier. **Figures 8.2 and 8.7.**
3. If the drive pin angle is more than seven degrees, use the fill plug in the axle-housing bowl. **Figures 8.4 through 8.8.**

Section 8 Rear Drive Axles

Check and Adjust the Oil

WARNING

Check the oil level when the axle is at room temperature. When hot, the oil temperature may be 190°F (88°C) or more and can cause burns. Also, a correct level is not obtained when the axle is warm or hot. Serious personal injury and damage to components can result.

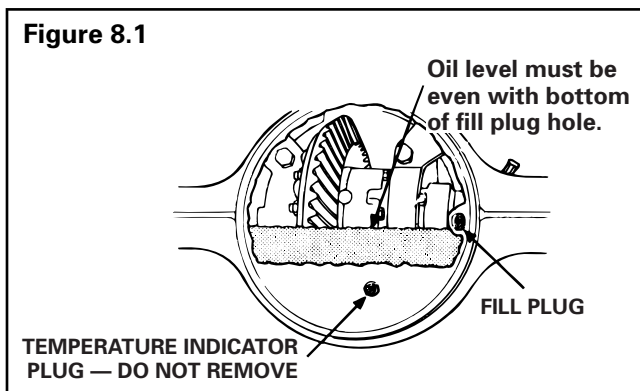

1. Park the vehicle on a level surface. The axle must be cold or near room temperature.
2. Clean the area around the fill plug. Remove the fill plug from the differential carrier or the axle-housing bowl (depending on the axle). Do not remove the temperature indicator plug. **Figures 8.2 through 8.8.**
3. Check the oil level. The level must be even with the bottom of the fill plug hole. **Figure 8.1.**
4. Install the fill plug. Tighten the plug to 35-50 lb-ft (48-67 N•m). 



Drain and Replace the Oil

NOTE: Drain the oil when it is warm. Remove and replace the oil filters each time you drain the oil.

1. Refer to Fill Plug Locations in this section.
2. Park the vehicle on a level surface. Put a large container under the axle.

3. Install the drain plug. Tighten the plug to 35-50 lb-ft (48-67 N•m). 
 - If an oil pump is used: Remove and replace the oil filters.
 - For Advanced Lube axles: Replace the oil filter every 100,000 miles (160 000 km).
4. Clean the area around the fill plug. Remove the fill plug from the differential carrier of the axle-housing bowl (depending on the axle). Do not remove the temperature indicator plug.
5. Add the specified oil until the oil is even with the bottom of the fill plug hole. Wait to allow the oil to flow through the axle.
 - **If the inter-axle differential has a top fill plug hole:** Add an additional two pints (0.946 liters) of the same oil into the inter-axle differential housing.
6. Check oil level again. If necessary, continue to add oil until it is even with the bottom of the fill plug hole.
7. Install the fill plug. Tighten the plug to 35-50 lb-ft (48-67 N•m). 

Inter-Axle Assemblies With Separate Housings

Meritor's SLHD, SQHD, STDD and SFDD forward-rear tandem axle carrier models include separate housings for inter-axle differential assemblies.

The baffles and dams used in these housings hold a reservoir of oil that can also trap wear particles and debris. Always purge the oil from these reservoirs when you change axle oil.

These carriers have separate drain and fill holes in either the inter-axle differential cover or housing.

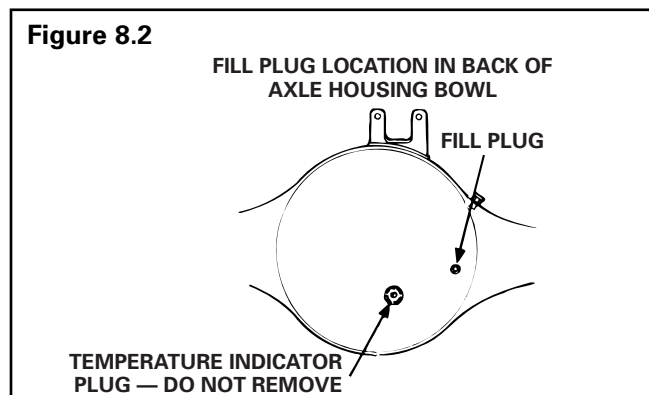

Section 8 Rear Drive Axles

Figure 8.3

FRONT MOUNTED SINGLE REDUCTION AXLES

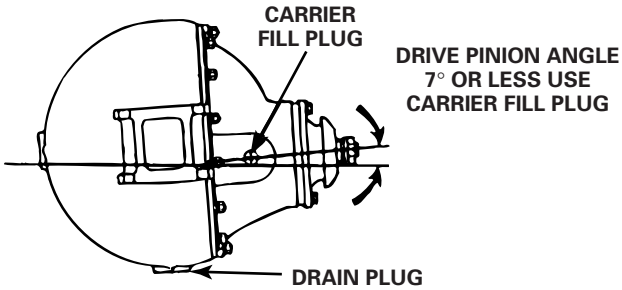

Figure 8.6

FRONT MOUNTED SINGLE
REDUCTION TANDEM AXLES

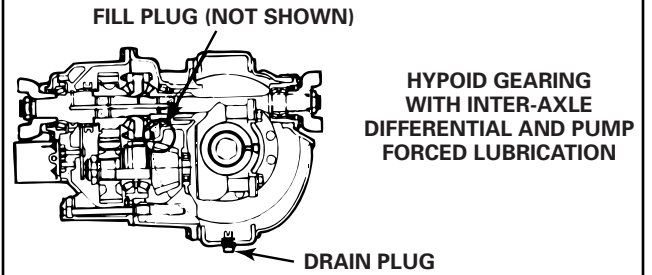

Figure 8.4

FRONT MOUNTED SINGLE REDUCTION AXLES

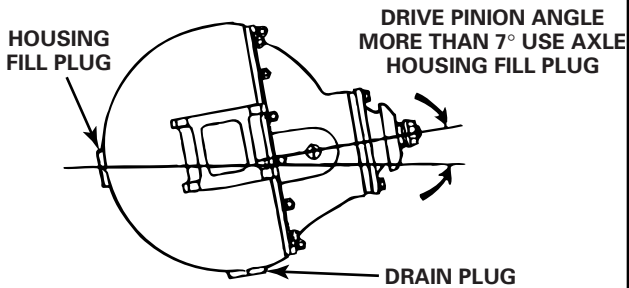

Figure 8.7

FRONT MOUNTED DOUBLE
REDUCTION AND TWO-SPEED AXLES

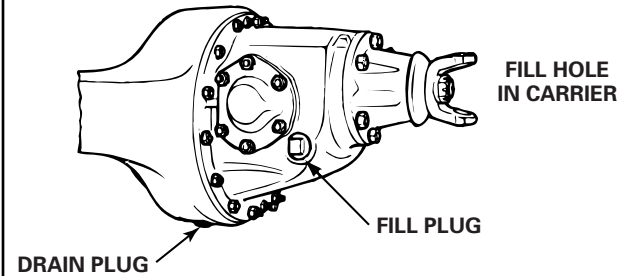

Figure 8.5

FRONT MOUNTED SINGLE REDUCTION TANDEM AXLES

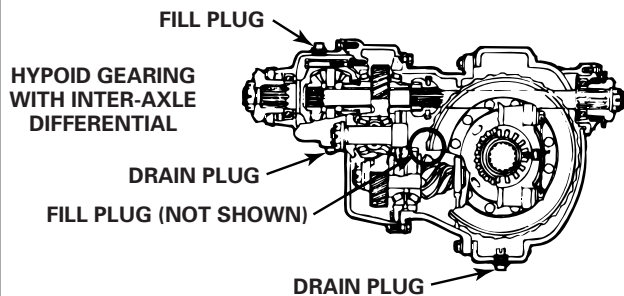
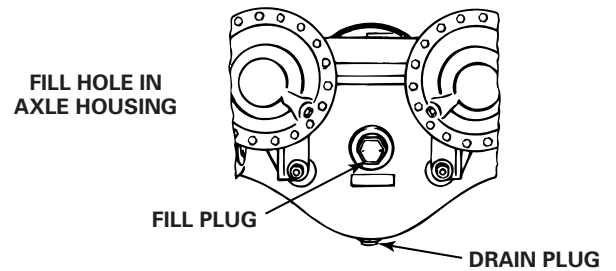

Figure 8.8

FRONT MOUNTED DOUBLE
REDUCTION AND TWO-SPEED AXLES



Section 8

Rear Drive Axles

Oil Change Intervals and Specifications for All Rear Drive Axles^①

Vocation or Vehicle Operation	Linehaul Motorhome Intercity Coach	City Delivery School Bus Fire Truck	Construction Transit Bus Refuse Yard Tractor Logging Heavy Haul Mining Oil Field Rescue
Initial Oil Change	No longer required as of January 1, 1993		
Check Oil Level	Every 25,000 miles (40 000 km), or the fleet maintenance interval (whichever comes first)	Every 10,000 miles (16 000 km), once a month, or the fleet maintenance interval (whichever comes first)	Every 5,000 miles (8000 km), once a month, or the fleet maintenance interval (whichever comes first) ②
Petroleum Based Oil Change on Axle <u>with</u> or <u>without</u> Pump and Filter System	Every 100,000 miles (160 000 km) or annually, whichever comes first	Every 50,000 miles (80 000 km) or annually, whichever comes first	Every 25,000 miles (40 000 km) or annually, whichever comes first
Synthetic Oil Change on Axle <u>without</u> Pump and Filter System ③	Every 250,000 miles (400 000 km) or annually, whichever comes first	Every 100,000 miles (160 000 km) or annually, whichever comes first	Every 50,000 miles (80 000 km) or annually, whichever comes first
Synthetic Oil Change on Axle <u>with</u> Pump and Filter System ③	Every 500,000 miles (800 000 km)	Every 250,000 miles (400 000 km)	Every 100,000 miles (160 000 km)
Filter Change on Axle with Pump and Filter System	Every 100,000 miles (160 000 km)	Every 100,000 miles (160 000 km)	Every 100,000 miles (160 000 km)

① If a No-Spin differential is installed, change the oil (petroleum or synthetic) at minimum interval or 40,000 miles (64 000 km) or a maximum interval or 50,000 miles (80 000 km).

② For continuous heavy-duty operation, check the oil level every 1,000 miles (1600 km). Add the correct type and amount of oil as required.

③ This interval applies to approved semi-synthetic and fully synthetic oils only. For list of approved extended-drain axle oils, refer to TP-9539, *Approved Rear Drive Axle Lubricants*. To order this publication, call ArvinMeritor's Customer Service Center at 800-535-5560.

Axle Oil Specifications

	Gear Oil Type	A.P.I. Specification	SAE Grade	RICO Specification	Military/SAE Specification	Outside Temperature
Non-Extended Drain Lubricants	Petroleum with EP Additives	GL-5	85W/140	O-76A	MIL-PRF-2105E and SAE J2360	Above +10°F (-12°C)
	Petroleum with EP Additives		80W/90	O-76D		Above -15°F (-26°C)
	Petroleum with EP Additives		75W/90	O-76E		Above -40°F (-40°C)
	Petroleum with EP Additives		75W	O-76J		From -40°F (-40°C) to 35°F (2°C)
	Petroleum with EP Additives		75W/140	O-76L		Above -40°F (-40°C)
Extended Drain Lubricants	Petroleum with Extended Drain Additives	GL-5	80W/90	—	MIL-PRF-2105E and SAE J2360	Above -15°F (-26°C)
	Semi-Synthetic		80W/90	—		Above -15°F (-26°C)
	Full Synthetic		75W/140	O-76M		Above -40°F (-40°C)
	Full Synthetic		75W/90	O-76N		Above -40°F (-40°C)

Section 8 Rear Drive Axles

Single Rear Drive Axle Oil Capacities*

Axle Model	Oil Capacity*	
	Pints	Liters
A-150	5.5	2.6
B-100	10.0	4.7
B-140	12.0	5.7
B-150	3.5	1.7
C-100	12.5	5.9
D-100	12.5	5.9
D-140	12.5	5.9
E-100	15.0	7.1
E-105	12.5	5.9
E-150	9.0	4.3
F-100	13.0	6.2
F-106	13.0	6.2
F-120	15.0	7.1
F-121	15.0	7.1
F-140	14.0	6.6
G-161	21.0	9.9
H-100	20.0	9.5
H-140	21.0	9.9
H-150	11.0	5.2
H-162	20.0	9.5
H-170	27.0	12.8
H-172	27.0	12.8
L-100	23.0	10.9
L-140	24.0	11.4
L-155	24.0	11.4
L-172	27.0	12.8
M-172	27.0	12.8
Q-100	31.0	14.7
Q-145	24.0	11.4
QT-140	24.0	11.4
R-100	30.0	14.2
R-140	28.0	13.3
R-155	28.0	13.3

Axle Model	Oil Capacity*	
	Pints	Liters
R-160	28.0	13.3
R-163	34.0	16.1
R-170	43.0	20.3
R-270	55.0	26.0
RL-170	48.0	22.7
RC-22-145	32.3	15.3
RC-23-160	41.0	19.4
RC-25-160	39.5	18.7
RS-13-120	18.4	8.7
RS-15-120	18.4	8.7
RS-15-210	14.3	6.8
RS-17-140	28.6	13.5
RS-17-145	33.6	15.9
RS-17-220	30.7	14.5
RS-19-145	33.2	15.7
RS-21-145	32.3	15.3
RS-21-230	38.9	18.4
RS-23-160	39.5	18.7
RS-23-161	37.2	17.6
RS-23-180	47.3	22.4
RS-23-186	47.3	22.4
RS-23-240	37.4	17.7
RS-23-380	63.6	30.1
RS-26-160	47.5	22.5
RS-26-180	46.6	22.0
RS-26-380	58.2	27.5
RS-30-180	46.6	22.0
RS-30-380	58.2	27.5
RS-38-380	53.1	25.1
S-170	43.0	20.3
U-140	24.0	11.4
U-170	43.0	20.3
U-270	55.0	26.0

Axle Model	Oil Capacity*	
	Pints	Liters
W-170	43.0	20.3
W-270	55.0	26.0
59722	30.5	14.4
59723	30.5	14.4
59732	30.5	14.4
59733	30.5	14.4
59843	30.5	14.4
61142	42.0	19.8
61143	41.0	19.3

* Oil capacities are for standard track axles that have been measured at various common drive pinion angles. The quantities listed include enough oil for both wheel ends. These oil capacities will change if the track or the drive pinion angle is different.

Section 8 Rear Drive Axles

Tandem Rear Drive Axle Oil Capacities

Axle Model	Carrier	Oil Capacity ①	
		Pints	Liters
RT-34-140	Forward	26.0	12.3
	Rear	35.0	16.6
RT-34-145	Forward	29.6	14.0
	Rear	25.4	12.0
RT-34-145P	Forward	25.7	12.1
	Rear	23.4	11.1
RT-40-140	Forward	30.2	14.3
	Rear	22.8	10.8
RT-40-145	Forward	30.2	14.3
	Rear	25.8	12.2
RT-40-160	Forward	39.1	18.5
	Rear	39.4	16.3
RT-44-145	Forward	29.3	13.9
	Rear	25.1	11.9
RT-44-145P	Forward	25.2	12.0
	Rear	22.9	11.0
RT-46-160	Forward	39.1	18.5
	Rear	34.4	16.3
RT-46-160P	Forward	39.3	18.6
	Rear	34.7	16.4
RT-46-164	Forward	39.1	18.5
	Rear	39.4	16.3
RT-48-180 ②	Forward	61.1	28.9
	Rear	36.8	17.4
RT-48-380 ②	Forward	61.1	28.9
	Rear	63.6	30.1
RT-52-160	Forward	44.1	20.9
	Rear	41.2	19.5
RT-52-160P	Forward	44.1	20.9
	Rear	41.2	19.5
RT-52-180 ②	Forward	56.1	26.5
	Rear	36.1	17.1
RT-52-185	Forward	56.1	26.5
	Rear	36.1	17.1
RT-52-380 ②	Forward	56.1	26.5
	Rear	58.2	27.5

Axle Model	Carrier	Oil Capacity ①	
		Pints	Liters
RT-58-180 ②	Forward	56.1	26.5
	Rear	36.1	17.1
RT-58-185	Forward	56.1	26.5
	Rear	36.1	17.1
RT-58-380 ②	Forward	56.1	26.5
	Rear	58.2	27.5
RT-70-380 ②	Forward	54.4	25.7
	Rear	53.1	25.1
SFHD	Forward	17.0	8.0
	Rear	16.5	7.8
SL-100	Forward	39.6	18.7
	Rear	37.7	17.8
SLHD	Forward	32.5	15.3
	Rear	32.0	15.1
SQ-100	Forward	39.6	18.7
	Rear	37.7	17.8
SQ-100A	Forward	39.3	18.6
	Rear	37.6	17.8
SQHD	Forward	34.0	16.0
	Rear	31.0	14.7
SR-170	Forward	55.0	26.0
	Rear	43.0	20.3
SRHD	Forward	39.0	18.5
	Rear	36.0	17.0
SSHHD	Forward	34.0	16.0
	Rear	28.0	13.2
ST-170	Forward	55.0	26.0
	Rear	43.0	20.3
STHD	Forward	34.0	16.0
	Rear	28.0	13.2
SU-170	Forward	55.0	26.0
	Rear	43.0	20.3
SUHD	Forward	34.0	16.0
	Rear	28.0	13.2
SW-170	Forward	55.0	26.0
	Rear	43.0	20.3

① Oil capacities are for standard track axles that have been measured at various common drive pinion angles. The quantities listed include enough oil for both wheel ends. These oil capacities will change if the track or the drive pinion angle is different.

② Forward carrier with oil pump system.

WARNING

To prevent serious eye injury, always wear safe eye protection when you perform vehicle maintenance or service.

TB Series Trailer Axles With Unitized Hub Assemblies

CAUTION

RICO TB Series trailer axles with unitized hub assemblies use conventional brakes and automatic slack adjusters, as well as conventional tire-wheel assemblies. Service these components as you would under normal operation conditions to avoid damage to components.

A unitized hub is permanently sealed and lubricated as an assembly. Do not attempt to remove the hub bearings, seals and lubricant. You cannot service or reinstall these components into a unitized hub assembly. Damage to components can result.

NOTE: Removal of the long-life bearings, seals and lubricant from the hub assembly will void the warranty.

Meritor's TB series trailer axle features a permanently sealed and lubricated unitized hub assembly designed to help reduce wheel-end maintenance.

The unitized hub is designed to remain in place on the axle for a minimum of five years or 500,000 miles (800 000 km).

Comparing a Unitized Wheel-End to a Conventional Wheel-End

On a unitized wheel-end, you install the hub, seal, lubricant and bearings onto the axle spindle as an assembly. **Figure 9.1.**

On a conventional wheel-end, you install the hub, seal, lubricant and bearings onto the axle spindle as separate components. **Figure 9.2.**

Figure 9.1

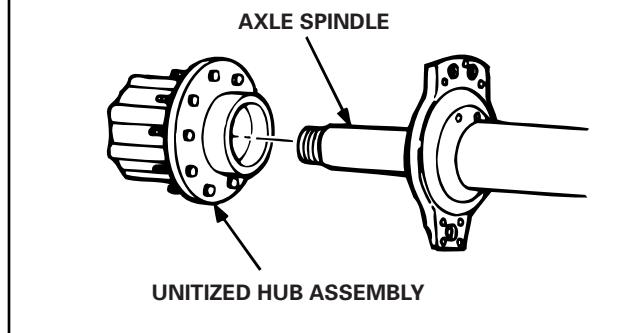
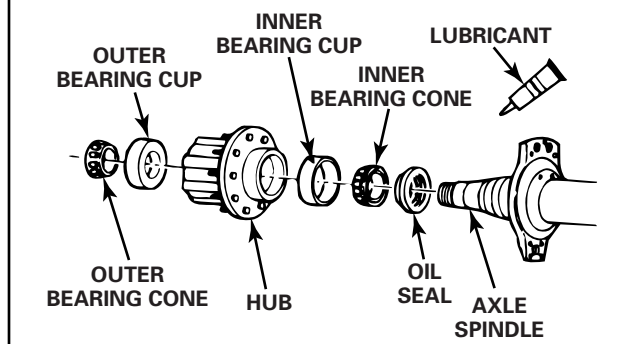

Figure 9.2



Section 9 Trailer Axles

Identifying a Trailer Axle With Unitized Wheel-Ends

- The model number designation for the TB series is prefixed with TB; for example, TB-4670 or TB-8670.
- The axle spindles are shorter with a single journal.
- The hubs contain non-serviceable bearings, seals and lubricant.
- The hubcaps screw onto the axle spindle and have no provisions for adding lubricant.
- The axle spindle retention hardware features a thicker inner nut and a bendable tab lockwasher.
- Warranty information is stamped on each unitized hub:

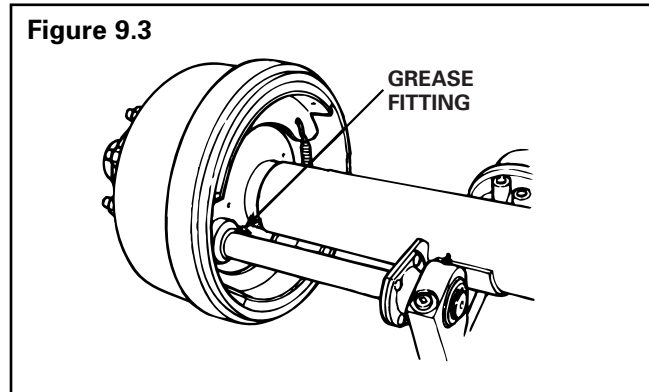

Important:

Removal of long-life bearings, seals or lubricant from the RICO TB series trailer axle hub will void the warranty. Refer to Technical Bulletin TP-96175 or call 800-535-5560 for information.



MERITOR®

TP-9700

Wheel Bearings and Wheel-Ends

Refer to Section 12 for oil and grease lubrication information.

Camshaft Bushings

Conventional and TB Series

Apply the specified grease at the grease fitting on the spider. Apply grease until new grease purges from all the seals. **Figure 9.3.**

Conventional and TB Series Camshaft Bushing Greasing Intervals and Specifications

Greasing Interval*	Grease	RICO Specification	NLGI Grade	Grease Description	Outside Temperature
Use the schedule below that gives the most frequent lubrication: <ul style="list-style-type: none"> • The lubrication schedule of the fleet. • The lubrication schedule of the vehicle manufacturer. • A minimum of four times during the life of the brake linings. 	Multi-Purpose Grease	O-617-A or O-617-B	1 or 2	Lithium 12-Hydroxy Stearate or Lithium Complex	Refer to the grease manufacturer's specifications for the temperature service limits.

* Applies to standard-duty on-highway service. Lubricate more frequently for heavy-duty applications. Determine intervals by inspecting lubricant every two weeks for a four month period. Look for hard, contaminated or missing grease. Choose an interval based on the inspection.

Conventional Trailer Axle Wheel-End Oil Change Intervals and Specifications

Check Oil Level	Oil Change *	RICO Specification	Specification Approval	Oil Description	Outside Temperature			
					°F		°C	
					Min.	Max.	Min.	Max.
1,000 miles (1600 km)	General Service: Change oil if the wheel-end is disturbed during wheel or hub removal or if the oil is contaminated. Standard-Duty Service: For 100,000 miles (160 000 km) or more a year, change the oil every 100,000 miles (160 000 km). For less than 100,000 miles (160 000 km) a year, change the oil once a year. Heavy-Duty Service: For 60,000 miles (96 000 km) or more a year, change oil every 30,000 miles (48 000 km). For less than 60,000 miles (96 000 km) a year, change the oil every 6 months.	O-76A Gear Oil	MIL-PRF-2105-E and SAE J2360	GL-5 SAE 85W/140	10	None	-12	None
		O-76D Gear Oil		GL-5 SAE 80W/90	-15	None	-26	None
		O-76E Gear Oil		GL-5 SAE 75W/90	-40	None	-40	None
		O-76J Gear Oil		GL-5 SAE 75W	-40	35	-40	2
		O-76L Gear Oil		GL-5 SAE 75W/140	-40	None	-40	None
		O-76M Full Synthetic Gear Oil		GL-5 SAE 75W/140	-40	None	-40	None
		O-76N Full Synthetic Gear Oil		GL-5 SAE 75W/90	-40	None	-40	None
		O-81 Full Synthetic Oil		SAE 50	-40	None	-40	None

* The recommended oil change interval is based on operating conditions, speeds and loads. Limited service applications may allow the recommended interval to be increased. Severe service applications may require the recommended interval to be reduced. For more information, contact ArvinMeritor's Customer Service Center at 800-535-5560.

Section 9 Trailer Axles

Conventional Trailer Axle Greasing Intervals and Specifications

Greasing Interval *	Grease	RICO Specification	NLGI Grade	Grease Description	Outside Temperature
<p>General Service: Grease the bearings if the wheel-end is disturbed during wheel or hub removal or if the grease is contaminated.</p> <p>Standard-Duty Service: For 100,000 miles (160 000 km) or more a year, grease the bearings every 100,000 miles (160 000 km). For less than 100,000 miles (160 000 km) a year, grease the bearings once a year.</p> <p>Heavy-Duty Service: For 60,000 miles (96 000 km) or more a year, grease the bearings every 30,000 miles (48 000 km). For less than 60,000 miles (96 000 km) a year, grease the bearings every 6 months.</p>	Multi-Purpose Grease	O-617-A or O-617-B	1 or 2	Lithium 12-Hydroxy Stearate or Lithium Complex	Refer to the grease manufacturer's specifications for the temperature service limits.
	Trailer Axle Bearing	O-647	00	Lithium Complex	

* The recommended greasing interval is based on operating conditions, speeds and loads. Limited service applications may allow the recommended interval to be increased. Severe service applications may require the recommended interval to be reduced. For more information, contact an ArvinMeritor service representative.

WARNING

To prevent serious eye injury, always wear safe eye protection when you perform vehicle maintenance or service.

Operating Information

Magnets and Magnetic Drain Plugs

Most RICO transfer cases are equipped with magnetic plugs having a minimum pick-up capacity of 20 ounces (0.57 kilograms) of low carbon steel.

NOTE: RICO recommends replacing the magnetic drain plug each time the oil is changed. Use the correct part. Pipe plugs will leak if used as a drain plug.

The magnetic drain plug can be reused if, after cleaning, the plug has a minimum pick-up capacity of 20 ounces (0.57 kilograms) of low carbon steel.

Breather

CAUTION

Cover the breather when steam cleaning the housing. If the breather is not covered, water enters the housing and contaminates the oil.

Breathers release pressure that builds up inside the transfer case during vehicle operation.

Seals

CAUTION

Always use the correct tools and procedures when you replace a seal to ensure that you correctly install the seal. A seal that is not correctly installed can leak. Damage to components can result.

Seals keep lubricant in and dirt out of a component. When they are worn or damaged, seals leak and produce low lubricant levels which may damage components.

Temperature Indicator

CAUTION

RICO transfer cases may operate above 190°F (88°C) without damage. However, if the oil temperature reaches 250°F (121°C), stop the vehicle immediately and check for the cause of overheating. Maximum continuous running oil temperature should not exceed 225°F (107°C). Damage to components can result.

Check and Adjust Oil Level

CAUTION

Use only SAE Grade 50W full synthetic oil, RICO specification O-81, in the transfer case. Petroleum base oils and synthetic base oils can react against sealing materials. Damage to components can result.

Only use new lubricant when you change or adjust the oil in the transfer case. Do not reuse lubricant, which can contain metallic particles and other contaminants. Damage to components can result.

1. Park the vehicle on a level surface.
2. Clean the area around the fill plug/fill cap. Remove the fill plug/fill cap from the transfer case. **Figure 10.1.** The oil level must be even with the bottom of the fill plug hole or the top of the stand pipe.
 - **If oil flows from the hole when you loosen the plug:** The oil level is high. Drain the oil to the bottom of the fill hole.
 - **If the oil level is below the bottom of fill/level plug hole or stand pipe:** Add the specified oil until oil is even with the bottom of the fill hole.
3. Install and tighten the fill plug to 35-50 lb-ft (47-68 N•m). 

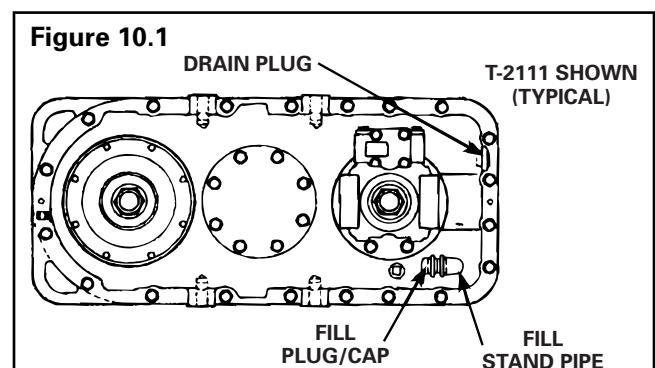

Section 10 Transfer Cases

Drain and Replace the Oil

1. Park the vehicle on a level surface. Put a large container under the transfer case.
2. Remove the drain plug from the bottom of the transfer case. Drain and discard the oil correctly. Clean the plug. **Figure 10.1.**
3. Install and tighten the drain plug to 35-50 lb-ft (47-68 N•m). **T**
4. Clean the area around the fill plug. Remove the fill plug from the transfer case.
5. Add the specified oil until the oil level is even with the bottom of the fill plug hole.
6. Install and tighten the fill plug to 35-50 lb-ft (47-68 N•m). **T**
7. Run the vehicle for 1/4 mile (0.4 km), then top off the oil level by adding oil to the fill opening.
8. Reinstall and tighten the fill plug to 35-50 lb-ft (47-68 N•m). **T**

Transfer Case Oil Change Intervals

Operation	On-Highway	Off-Highway
Check Oil Level	2,000 miles (3200 km)	40 operating hours
Initial Oil Change	2,500 miles (4000 km)	40-100 operating hours
Scheduled Oil Change	12,000-25,000 miles (19 000-40 000 km)	200-300 operating hours

Transfer Case Oil Specifications^{①④⑤}

Oil Description	RICO Specification	A.P.I. Specification	Military Specification	SAE Grade	Outside Temperature
Petroleum GL-1 Oil with Rust and Oxidation Inhibitor ^②	—	A.P.I. GL-1	—	90W 80W	Above 10°F (-12°C) Above -15°F (-26°C)
Heavy Duty Engine Oil ^②	—	A.P.I.-CD, CE, SF or SG ^⑥	—	50W 40W 30W	Above 10°F (-12°C) Above 10°F (-12°C) Above -12°F (-26°C)
Full Synthetic Oil ^③	O81	—	—	50W	Above -40°F (-40°C)
A.P.I. GL-5 (Axle Lube) ^①	DO NOT USE IN TRANSFER CASES				

^① Do Not use multi-viscosity (I.E. 80/90W) GL-5 Gear Oil (axle lube).

^② 90W GL-1 or 50W motor oil is same viscosity and commonly used above 10°F (-12°C).

^③ RICO approved full synthetic oil for manual ZFRICOTransmissions is also approved for RICOtransfer cases. Use synthetic oil only if the transfer case was initially filled with synthetic oil.

^④ Do not mix or switch oil types. Use the same oil that initially filled the transfer case.

^⑤ Do not use multi-viscosity oils.

^⑥ Current designations are acceptable.

Transfer Case Oil Capacities

Transfer Case Model	Oil Capacity	
	Pints*	Liters*
T-32	2.0	0.95
T-136	14.0	6.62
T-215	3.0	1.42
T-221	4.0	1.89
T-223	5.0	2.37
T-226	6.5	3.07
T-228	21.0	9.93
T-232	6.2	2.93
T-1138	13.5	6.38
T-2111	3.0	1.42
T-2111-HD	5.0	2.37
T-2111-HT	5.0	2.37
T-2111-PD	10.0	4.73
T-2111-SD	5.0	2.37
T-2120	4.0	1.89
T-2120-RS	6.5	3.10
T-600	6.2	2.93

* Due to the varied transfer case configurations, these fill quantities are for reference only. The fill procedure for all transfer cases is as follows:

1. Fill to the top of the stand pipe or fill hole.
2. Run the vehicle for 1/4 mile (0.4 km).
3. Top off the oil level.
4. Check that the sump temperature does not exceed 225°F (107°C).

Section 11

Transmissions

WARNING

To prevent serious eye injury, always wear safe eye protection when you perform vehicle maintenance or service.

NOTE: For a list of synthetic oil suppliers, call ArvinMeritor's Customer Service Center at 800-535-5560 and order TP-2053. This bulletin is also available from the Technical Library section on ArvinMeritor's web site at arvinmeritor.com. Click Products & Services/Tech Library Icon/HVS Publications/Technical Bulletins/Transmissions.

Recommended Oil Drain Conditions Based on Used-Oil Analysis

Manual Transmission Oils

If used transmission oil analyses indicate that any one of these criteria is not met, drain the used oil and replace it with an oil that is recommended for manual transmissions.

Used-Oil Analyses (ppm = parts per million)

Iron (Fe)	If level is greater than 500 ppm, drain and replace the oil.
Silicon (Si)	If level is greater than 100 ppm, drain and replace the oil.
Water (H ₂ O)	If level is greater than 0.3%, drain and replace the oil.

Magnets and Magnetic Drain Plugs

All ZF RICO transmissions have four magnets in the bottom of the main case. The magnets and magnetic plugs have a minimum pick-up capacity of 1.5 pounds (0.7 kilograms) of low carbon steel.

NOTE: ZF RICO recommends replacing the magnetic drain plug each time the oil is changed. Use the correct part. Pipe plugs will leak if used as a drain plug.

The magnetic drain plug can be reused if, after cleaning, the plug has a minimum pick-up capacity of 1.5 pounds (0.7 kilograms) of low carbon steel.

Transmission Oil Coolers

Required

- An engine has a rating of 399 HP or above.
- The transmission operating temperature is always above 225°F (107°C) at continuous operation or reaches 275°F (135°C) during intermittent operation.

Recommended

- An engine has a rating of 350 to 398 HP.
- Some aerodynamic vehicles that have engine ratings below 399 HP because of the amount of air that flows over the transmission to dissipate heat.

Temperature Indicator

The temperature indicator is optional on ZF RICO transmissions. The temperature sending unit is on the bottom right side of the main case. The normal operating temperature range is less than 225°F (107°C).

Use the temperature indicator gauge to check transmission operation. For example:

- If the temperature suddenly rises to 275°F (135°C) or more, check the transmission for the cause of the increase.
- When operating a vehicle on a mountain grade, if the temperature increases 50-75°F but returns to the normal operating temperature, this indicates a normal operating condition. If the temperature does not return to the normal range, check the transmission.

Oil Level

Before You Check the Oil Level

1. The oil must be at room temperature.
2. The vehicle must be parked for at least 10 minutes.

Check and Adjust the Oil Level

1. Park the vehicle on a level surface.

NOTE: If foam appears when you remove the fill plug, the oil is too hot to check. Install the oil plug and allow the oil to cool. If oil flows from the fill plug hole when you remove the plug, the oil level is too high. Drain the oil to the correct level.

2. Clean the area by the fill plug. Remove the fill plug from the side of the transmission.
3. Check for oil leaks. If a transmission oil leak is evident, refer to the Troubleshooting section of Maintenance Manual 26A, 9-, 10- and 13-Speed Transmissions, for procedures. To order a copy of this manual, call ArvinMeritor's Customer Service Center at 800-535-5560.
4. Check the transmission oil level. Verify that it is **EVEN WITH** the bottom of the fill plug. If the oil level is **BELOW** the bottom of the oil fill plug, add the specified oil. **Figure 11.1.**

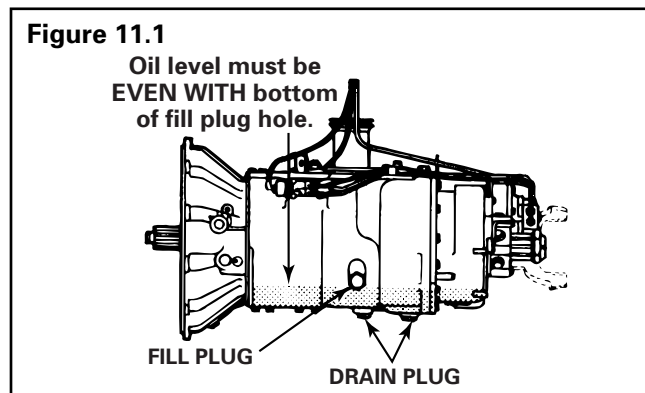

5. Install the oil fill plug and tighten it to 35-50 lb-ft (48-67 N•m).
6. Operate the vehicle for 5 minutes. Check for transmission oil leaks and correct operation.

Drain and Replace the Oil

NOTE: Drain the oil when the transmission is hot.

1. Park the vehicle on a level surface. Place a large container under the transmission. Place a screen on top of the container.
2. Remove the drain plugs from the bottom of the transmission. Drain the oil. Follow United States Environmental Protection Agency (EPA) guidelines to recycle used oil.
3. Inspect the screen on top of the container for metal particles and damaged parts.

Service the Transmission if Necessary

1. If the transmission is disassembled or replaced and a transmission oil cooler is used, remove the cooler.
2. Remove the oil from the oil cooler and the oil lines. Follow United States Environmental Protection Agency (EPA) guidelines to recycle used oil.
3. Install the oil cooler and the oil lines. Tighten the fittings to the vehicle manufacturer's specifications.
4. Install the drain plug and tighten it to 35-50 lb-ft (48-67 N•m).
5. Clean the air by the fill plug. Remove the fill plug from the side of the transmission.

CAUTION

Only use the specified oil. Do not use multi-viscosity engine oils or Extreme Pressure (EP) GL-5 gear oils. Damage to components can result. The use of multi-viscosity or EP oils will void ZF Meritor's warranty.

6. Add the specified transmission oil through the fill plug hole. Add the oil until the oil level is **EVEN WITH** the bottom of the fill plug hole.
7. Install and tighten the fill plug to 35-50 lb-ft (48-67 N•m).
8. Operate the vehicle for 5 minutes. Check for correct operation.

Section 11

Transmissions

Oil Change Intervals

Manual Transmissions
 Engine Synchro Shift™ (ESS™)
 SureShift™

Check Oil Level	Approved Petroleum Lubricant Oil Change	Approved Synthetic Oil Change
10,000 miles (16 000 km)	50,000 miles (80 000 km)	500,000 miles (800 000 km) ①

Oil Change Specifications

Manual Transmissions②
 Engine Synchro Shift™ (ESS™)
 SureShift™

Oil Description	RICO Specification	A.P.I. Specification	Military Specification Approval	SAE Grade	Outside Temperature
Heavy-Duty Engine Oil	—	A.P.I. -CD, -CE, -SG, -SH or SJ ③	MIL-L-2104 E or F ③	50 40 30	Above 10°F (-12°C) Above 10°F (-12°C) Above -15°F (-26°C)
Petroleum GL-1 Oil with Rust and Oxidation Inhibitor	—	A.P.I. - GL-1	—	90 80	Above 10°F (-12°C) Above -15°F (-26°C)
Full-Synthetic Oil	O-81	—	—	50	Above -40°F (-40°C)

① This interval is for linehaul applications.

② Do not use multi-viscosity or EP (Extreme Pressure) GL-5 gear oils. DO NOT MIX OILS IN THE TRANSMISSION.

③ Current designations are acceptable.

FreedomLine™ Transmission Oil Specification

Oil Description	ZF RICO Specification	A.P.I. Specification	Military Specification Approval	SAE Grade	Outside Temperature
Full-Synthetic Oil	Exxon Mobil SHC 50	—	—	50	Above -60°F (-51°C)

Manual Transmissions

9 - SPEED

10 - SPEED

13 - SPEED

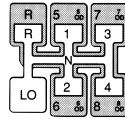
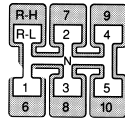
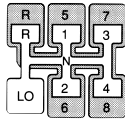

9-Speed Manual

Transmission Description	Model Number	Torque Rating lb-ft	Overall Ratio		Rev. L	Rev. H	Ratio and Percent Step																	
			FWD.	REV.			L %	1 %	2 %	3 %	4 %	5 %	6 %	7 %	8									
9-Speed Direct Drive, A Ratio	M-11G9A-M11	1,150																						
	M-12G9A-M12	1,250																						
	M-13G9A-M13	1,350	13.41	13.17	13.17	3.73	13.41	48	9.05	39	6.51	37	4.74	34	3.53	38	2.56	39	1.84	37	1.34	34	1.00	
	M-14G9A-M14	1,450																						
	M-15G9A-M15	1,550																						
9-Speed Overdrive, A Ratio	MO-12G9A-M12	1,250	13.41	13.17	9.81	2.78	9.99	48	6.74	39	4.85	37	3.53	34	2.63	38	1.91	39	1.37	37	1.00	34	0.74	
	MO-13G9A-M13	1,350																						
	MO-14G9A-M14	1,450																						
9-Speed Overdrive, B Ratio	MO-11G9B-M11	1,150																						
	MO-12G9B-M12	1,250																						
	MO-13G9B-M13	1,350	17.74	17.42	12.60	3.24	12.83	67	7.69	40	5.48	41	3.89	38	2.81	42	1.98	40	1.41	41	1.00	38	0.72	
	MO-14G9B-M14	1,450																						
	MO-15G9B-M15	1,550																						

9-Speed Manual — Additional Specifications

Model	Optional Internal Oil Pump	Oil Capacity (pints)	Length (inches)	Weight (lbs.*)	PTO Speed (% of engine)
M-11G9A-M11		20.5	29.5	605	75.8
M-12G9A-M12		20.5	29.5	605	75.8
M-13G9A-M13		20.5	29.5	605	75.8
M-14G9A-M14		20.5	29.5	605	75.8
M-15G9A-M15	STD.	20.5	29.5	608	75.8
MO-12G9A-M12		20.5	29.5	605	101.7
MO-13G9A-M13		20.5	29.5	605	101.7
MO-14G9A-M14		20.5	29.5	605	101.7
MO-11G9B-M11		20.5	28.9	605	87.1
MO-12G9B-M12		20.5	28.9	605	87.1
MO-13G9B-M13		20.5	29.5	605	87.1
MO-14G9B-M14		20.5	29.5	605	87.1
MO-15G9B-M15	STD.	20.5	29.5	608	87.1

*Weights are approximate, less clutch housing, shift controls, output yoke and lubricant.

13-Speed Manual

Transmission Description	Model Number	Torque Rating lb-ft	Overall Ratio		Rev. L	Rev. H	Ratio and Percent Step																								
			FWD.	REV.			L %	1 %	2 %	3 %	4 %	5 %	6 %	7 %	8 %	9 %	10 %	11 %	12												
13-Speed Overdrive, A Ratio	RM013-145A	1,450	15.43	15.15	13.15	3.73	13.39	48	9.03	39	6.50	37	4.74	34	3.53	38	2.56	15	2.22	21	1.84	15	1.60	19	1.34	15	1.17	17	1.00	15	0.87

13-Speed Manual — Additional Specifications

Model	Optional Internal Oil Pump	Oil Capacity (pints)	Length (inches)	Weight (lbs.*)	PTO Speed (% of engine)
RM013-145A		22	32.4	666	75.8

*Weights are approximate, less clutch housing, shift controls, output yoke and lubricant.

Section 11 Transmissions

10-Speed Manual

Transmission Description	Model Number	Torque Rating lb-ft	Overall Ratio		Rev. L	Rev. H	Ratio and Percent Step																				
			FWD.	REV.			1 %	2 %	3 %	4 %	5 %	6 %	7 %	8 %	9 %	10											
10-Speed Direct Drive, A Ratio	M-11G10A-M11	1,150																									
	M-12G10A-M12	1,250																									
	M-13G10A-M13	1,350	15.02	16.71	16.71	3.73	15.02	35	11.14	35	8.26	37	6.02	34	4.48	34	3.35	35	2.48	35	1.84	37	1.34	34	1.00		
	M-14G10A-M14	1,450																									
	M-15G10A-M15	1,550																									
	M-14G10A-M16 ¹	1,450																									
10-Speed Overdrive, A Ratio	MO-11G10A-M11	1,150																									
	MO-12G10A-M12	1,250																									
	MO-13G10A-M13	1,350																									
	MO-14G10A-M14	1,450	15.02	16.71	12.45	2.78	11.19	35	8.30	35	6.15	37	4.48	34	3.34	34	2.50	35	1.85	35	1.37	37	1.00	34	0.74		
	MO-15G10A-M15	1,550																									
	MO-14G10A-M16 ¹	1,450																									
	MO-16G10A-M16	1,650																									
MO-16G10A-M18 ¹	1,650																										
10-Speed Overdrive, C Ratio	MO-11G10C-M11	1,150																									
	MO-12G10C-M12	1,250																									
	MO-13G10C-M13	1,350																									
	MO-14G10C-M14	1,450																									
	MO-15G10C-M15	1,550																									
	MO-16G10C-M16	1,650	17.53	19.49	14.15	2.88	12.72	38	9.23	37	6.75	37	4.92	38	3.57	38	2.58	38	1.88	37	1.37	37	1.00	38	0.73		
	MO-14G10C-M16 ¹	1,450																									
	MO-16G10C-M18	1,650																									
	MO-17G10C-M17	1,750																									
	MO-17G10C-M19	1,750																									
MO-18G10C-M18	1,850																										
MO-18G10C-M20 ¹	1,850																										

¹ Available with Torq-2 with either a 100 lb-ft or 200 lb-ft increase in the top two gears in CAT/Cummins engines. Other Torq-2 combinations are available, call your OEM representative for details.

10-Speed Manual — Additional Specifications

Model	Optional Internal Oil Pump	Oil Capacity (pints)	Length (inches)	Weight (lbs.*)	PTO Speed (% of engine)
M-11G10A-M11		20.5	29.5	605	75.8
M-12G10A-M12		20.5	29.5	605	75.8
M-13G10A-M13		20.5	29.5	605	75.8
M-14G10A-M14		20.5	29.5	605	75.8
M-15G10A-M15	STD.	20.5	29.5	608	75.8
M-14G10A-M16	STD.	20.5	29.5	608	75.8
MO-11G10A-M11		20.5	29.5	605	75.8
MO-12G10A-M12		20.5	29.5	605	75.8
MO-13G10A-M13		20.5	29.5	605	101.7
MO-14G10A-M14		20.5	29.5	605	101.7
MO-15G10A-M15	STD.	20.5	29.5	608	101.7
MO-14G10A-M16	STD.	20.5	29.5	608	101.7
MO-16G10A-M16	STD.	20.5	29.5	608	101.7
MO-16G10A-M18	STD.	20.5	29.5	608	101.7
MO-11G10C-M11		20.5	29.5	605	98.2
MO-12G10C-M12		20.5	29.5	605	98.2
MO-13G10C-M13		20.5	29.5	605	98.2
MO-14G10C-M14		20.5	29.5	605	98.2
MO-15G10C-M15	STD.	20.5	29.5	608	98.2
MO-16G10C-M16	STD.	20.5	29.5	608	98.2
MO-14G10C-M16	STD.	20.5	29.5	608	98.2
MO-16G10C-M18	STD.	20.5	29.5	608	98.2
MO-17G10C-M17	STD.	20.5	29.5	608	98.2
MO-17G10C-M19	STD.	20.5	29.5	608	98.2
MO-18G10C-M18	STD.	20.5	29.5	608	98.2
MO-18G10C-M20	STD.	20.5	29.5	608	98.2

*Weights are approximate, less clutch housing, shift controls, output yoke and lubricant.

ESS System Automated Transmissions

9 - SPEED

10 - SPEED

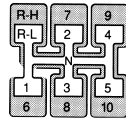
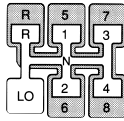

9-Speed ESS

Transmission Description	Model Number	Torque Rating lb-ft	Overall Ratio		Rev. L	Rev. H	Ratio and Percent Step																	
			FWD.	REV.			L %	1 %	2 %	3 %	4 %	5 %	6 %	7 %	8									
9-Speed Direct Drive, A Ratio	M-11G9A-X11	1,150																						
	M-12G9A-X12	1,250																						
	M-13G9A-X13	1,350	13.41	13.17	13.17	3.73	13.41	48	9.05	39	6.51	37	4.74	34	3.53	38	2.56	39	1.84	37	1.34	34	1.00	
	M-14G9A-X14	1,450																						
	M-15G9A-X15	1,550																						
9-Speed Overdrive, A Ratio	MO-12G9A-X12	1,250	13.41	13.17	9.81	2.78	9.99	48	6.74	39	4.85	37	3.53	34	2.63	38	1.91	39	1.37	37	1.00	34	0.74	
	MO-13G9A-X13	1,350																						
	MO-14G9A-X14	1,450																						
9-Speed Overdrive, B Ratio	MO-11G9B-X11	1,150																						
	MO-12G9B-X12	1,250																						
	MO-13G9B-X13	1,350	17.74	17.42	12.60	3.24	12.83	67	7.69	40	5.48	41	3.89	38	2.81	42	1.98	40	1.41	41	1.00	38	0.72	
	MO-14G9B-X14	1,450																						
	MO-15G9B-X15	1,550																						

FOR ENGINE TYPE:
X = Add "D" for Detroit Diesel or "E" for CAT/Cummins engine.

9-Speed ESS — Additional Specifications

Model	Optional Internal Oil Pump	Oil Capacity (pints)	Length (inches)	Weight (lbs.*)	PTO Speed (% of engine)
M-11G9A-X11		20.5	29.5	605	75.8
M-12G9A-X12		20.5	29.5	605	75.8
M-13G9A-X13		20.5	29.5	605	75.8
M-14G9A-X14		20.5	29.5	605	75.8
M-15G9A-X15	STD.	20.5	29.5	608	75.8
MO-12G9A-X12		20.5	29.5	605	101.7
MO-13G9A-X13		20.5	29.5	605	101.7
MO-14G9A-X14		20.5	29.5	605	101.7
MO-11G9B-X11		20.5	29.5	605	87.1
MO-12G9B-X12		20.5	29.5	605	87.1
MO-13G9B-X13		20.5	29.5	605	87.1
MO-14G9B-X14		20.5	29.5	605	87.1
MO-15G9B-X15	STD.	20.5	29.5	608	87.1

*Weights are approximate, less clutch housing, shift controls, output yoke and lubricant.

Section 11 Transmissions

10-Speed ESS

Transmission Description	Model Number	Torque Rating lb-ft	Overall Ratio		Rev. L	Rev. H	Ratio and Percent Step																			
			FWD.	REV.			1 %	2 %	3 %	4 %	5 %	6 %	7 %	8 %	9 %	10										
10-Speed Direct Drive, A Ratio	M-11G10A-X11	1,150																								
	M-12G10A-X12	1,250																								
	M-13G10A-X13	1,350	15.02	16.71	16.71	3.73	15.02	35	11.14	35	8.26	37	6.02	34	4.48	34	3.35	35	2.48	35	1.84	37	1.34	34	1.00	
	M-14G10A-X14	1,450																								
	M-15G10A-X15	1,550																								
	M-14G10A-E16	1,450																								
10-Speed Overdrive, A Ratio	MO-11G10A-X11	1,150																								
	MO-12G10A-X12	1,250																								
	MO-13G10A-X13	1,350																								
	MO-14G10A-X14	1,450	15.02	16.71	12.45	2.78	11.19	35	8.30	35	6.15	37	4.48	34	3.34	34	2.50	35	1.85	35	1.37	37	1.00	34	0.74	
	MO-15G10A-X15	1,550																								
	MO-14G10A-E16 ¹	1,450																								
	MO-16G10A-X16	1,650																								
MO-16G10A-E18	1,650																									
10-Speed Overdrive, C Ratio	MO-11G10C-X11	1,150																								
	MO-12G10C-X12	1,250																								
	MO-13G10C-X13	1,350																								
	MO-14G10C-X14	1,450																								
	MO-15G10C-X15	1,550																								
	MO-16G10C-X16	1,650	17.53	19.49	14.15	2.88	12.72	38	9.23	37	6.75	37	4.92	38	3.57	38	2.58	38	1.88	37	1.37	37	1.00	38	0.73	
	MO-14G10C-E16 ¹	1,450																								
	MO-16G10C-E18 ¹	1,650																								
	MO-17G10C-X17	1,750																								
	MO-17G10C-E19	1,750																								
	MO-18G10C-X18	1,850																								
MO-18G10C-E20 ¹	1,850																									

FOR ENGINE TYPE: X = Add "D" for Detroit Diesel or "E" for CAT/Cummins engine. E = Available in CAT/Cummins engine only.

¹ Available with Torq-2 with either a 100 lb-ft or 200 lb-ft increase in the top two gears. Other Torq-2 combinations are available, call your OEM representative for details.

10-Speed ESS — Additional Specifications

Model	Optional Internal Oil Pump	Oil Capacity (pints)	Length (inches)	Weight (lbs.*)	PTO Speed (% of engine)
M-11G10A-X11		20.5	29.5	605	75.8
M-12G10A-X12		20.5	29.5	605	75.8
M-13G10A-X13		20.5	29.5	605	75.8
M-14G10A-X14		20.5	29.5	605	75.8
M-15G10A-X15	STD.	20.5	29.5	608	75.8
M-14G10A-E16	STD.	20.5	29.5	608	75.8
MO-11G10A-X11		20.5	29.5	605	75.8
MO-12G10A-X12		20.5	29.5	605	75.8
MO-13G10A-X13		20.5	29.5	605	101.7
MO-14G10A-X14		20.5	29.5	605	101.7
MO-15G10A-X15	STD.	20.5	29.5	608	101.7
MO-14G10A-E16	STD.	20.5	29.5	608	101.7
MO-16G10A-X16	STD.	20.5	29.5	608	101.7
MO-16G10A-E18	STD.	20.5	29.5	608	101.7
MO-11G10C-X11		20.5	29.5	605	98.2
MO-12G10C-X12		20.5	29.5	605	98.2
MO-13G10C-X13		20.5	29.5	605	98.2
MO-14G10C-X14		20.5	29.5	605	98.2
MO-15G10C-X15	STD.	20.5	29.5	608	98.2
MO-16G10C-X16	STD.	20.5	29.5	608	98.2
MO-14G10C-E16	STD.	20.5	29.5	608	98.2
MO-16G10C-X18	STD.	20.5	29.5	608	98.2
MO-17G10C-E17	STD.	20.5	29.5	608	98.2
MO-17G10C-E19	STD.	20.5	29.5	608	98.2
MO-18G10C-E18	STD.	20.5	29.5	608	98.2
MO-18G10C-X20	STD.	20.5	29.5	608	98.2

*Weights are approximate, less clutch housing, shift controls, output yoke and lubricant.

SureShift™ Automated Transmissions (All J1939 Engines)

9-Speed SureShift

Transmission Description	Model Number	Torque Rating lb-ft	Overall Ratio		Rev. L	Rev. H	Ratio and Percent Step																
			FWD.	REV.			L	%	1	%	2	%	3	%	4	%	5	%	6	%	7	%	8
9-Speed Direct Drive, A Ratio	M-11G9A-S11	1,150																					
	M-12G9A-S12	1,250																					
	M-13G9A-S13	1,350	13.41	13.17	13.17	3.73	13.41	48	9.05	39	6.51	37	4.74	34	3.53	38	2.56	39	1.84	37	1.34	34	1.00
	M-14G9A-S14	1,450																					
	M-15G9A-S15	1,550																					
9-Speed Overdrive, A Ratio	MO-12G9A-S12	1,250																					
	MO-13G9A-S13	1,350	13.41	13.17	9.81	2.78	9.99	48	6.74	39	4.85	37	3.53	34	2.63	38	1.91	39	1.37	37	1.00	34	0.74
	MO-14G9A-S14	1,450																					
9-Speed Overdrive, B Ratio	MO-11G9B-S11	1,150																					
	MO-12G9B-S12	1,250																					
	MO-13G9B-S13	1,350	17.74	17.42	12.60	3.24	12.83	67	7.69	40	5.48	41	3.89	38	2.81	42	1.98	40	1.41	41	1.00	38	0.72
	MO-14G9B-S14	1,450																					
	MO-15G9B-S15	1,550																					

9-Speed SureShift — Additional Specifications

Model	Optional Internal Oil Pump	Oil Capacity (pints)	Length (inches)	Weight (lbs.*)	PTO Speed (% of engine)
M-11G9A-S11		20.5	29.5	605	75.8
M-12G9A-S12		20.5	29.5	605	75.8
M-13G9A-S13		20.5	29.5	605	75.8
M-14G9A-S14		20.5	29.5	605	75.8
M-15G9A-S15	STD.	20.5	29.5	608	75.8
MO-12G9A-S12		20.5	29.5	605	101.7
MO-13G9A-S13		20.5	29.5	605	101.7
MO-14G9A-S14		20.5	29.5	605	101.7
MO-11G9B-S11		20.5	29.5	605	87.1
MO-12G9B-S12		20.5	29.5	605	87.1
MO-13G9B-S13		20.5	29.5	605	87.1
MO-14G9B-S14		20.5	29.5	605	87.1
MO-15G9B-S15	STD.	20.5	29.5	608	87.1

*Weights are approximate, less clutch housing, shift controls, output yoke and lubricant.

Section 11 Transmissions

10-Speed SureShift

Transmission Description	Model Number	Torque Rating lb-ft	Overall Ratio		Rev. L	Rev. H	Ratio and Percent Step																		
			FWD.	REV.			1 %	2 %	3 %	4 %	5 %	6 %	7 %	8 %	9 %	10									
10-Speed Direct Drive, A Ratio	M-11G10A-S11	1,150																							
	M-12G10A-S12	1,250																							
	M-13G10A-S13	1,350	15.02	16.71	16.71	3.73	15.02	35	11.14	35	8.26	37	6.02	34	4.48	34	3.35	35	2.48	35	1.84	37	1.34	34	1.00
	M-14G10A-S14	1,450																							
	M-15G10A-S15	1,550																							
	M-14G10A-S16 ¹	1,450																							
10-Speed Overdrive, A Ratio	MO-11G10A-S11	1,150																							
	MO-12G10A-S12	1,250																							
	MO-13G10A-S13	1,350																							
	MO-14G10A-S14	1,450	15.02	16.71	12.45	2.78	11.19	35	8.30	35	6.15	37	4.48	34	3.34	34	2.50	35	1.85	35	1.37	37	1.00	34	0.74
	MO-15G10A-S15	1,550																							
	MO-14G10A-S16 ¹	1,450																							
	MO-16G10A-S16	1,650																							
	MO-16G10A-S18 ¹	1,650																							
10-Speed Overdrive, C Ratio	MO-11G10C-S11	1,150																							
	MO-12G10C-S12	1,250																							
	MO-13G10C-S13	1,350																							
	MO-14G10C-S14	1,450																							
	MO-15G10C-S15	1,550	17.53	19.49	14.15	2.88	12.72	38	9.23	37	6.75	37	4.92	38	3.57	38	2.58	38	1.88	37	1.37	37	1.00	38	0.73
	MO-16G10C-S16	1,650																							
	MO-14G10C-S16 ¹	1,450																							
	MO-16G10C-S18 ¹	1,650																							
	MO-17G10C-S17	1,750																							
	MO-17G10C-S19	1,750																							
MO-18G10C-S18	1,850																								
MO-18G10C-S20 ¹	1,850																								

¹ Available with Torq-2 with either a 100 lb-ft or 200 lb-ft increase in the top two gears with CAT/Cummins engines. Other Torq-2 combinations are available, call your OEM representative for details.

10-Speed SureShift — Additional Specifications

Model	Optional Internal Oil Pump	Oil Capacity (pints)	Length (inches)	Weight (lbs.*)	PTO Speed (% of engine)
M-11G10A-S11		20.5	29.9	605	75.8
M-12G10A-S12		20.5	29.9	605	75.8
M-13G10A-S13		20.5	29.5	605	75.8
M-14G10A-S14		20.5	29.5	605	75.8
M-15G10A-S15	STD.	20.5	29.5	608	75.8
M-14G10A-S16	STD.	20.5	29.5	608	75.8
MO-11G10A-S11		20.5	29.9	605	75.8
MO-12G10A-S12		20.5	29.9	605	75.8
MO-13G10A-S13		20.5	29.5	605	101.7
MO-14G10A-S14		20.5	29.5	605	101.7
MO-15G10A-S15	STD.	20.5	29.5	608	101.7
MO-14G10A-S16	STD.	20.5	29.5	608	101.7
MO-16G10A-S16	STD.	20.5	29.5	608	101.7
MO-16G10A-S18	STD.	20.5	29.5	608	101.7
MO-11G10C-S11		20.5	29.5	605	98.2
MO-12G10C-S12		20.5	29.5	605	98.2
MO-13G10C-S13		20.5	29.5	605	98.2
MO-14G10C-S14		20.5	29.5	605	98.2
MO-15G10C-S15	STD.	20.5	29.5	608	98.2
MO-16G10C-S16	STD.	20.5	29.5	608	98.2
MO-16G10C-S18	STD.	20.5	29.5	608	98.2
MO-17G10C-S17	STD.	20.5	29.5	608	98.2
MO-17G10C-S19	STD.	20.5	29.5	608	98.2
MO-18G10C-S18	STD.	20.5	29.5	608	98.2
MO-18G10C-S20	STD.	20.5	29.5	608	98.2

*Weights are approximate, less clutch housing, shift controls, output yoke and lubricant.

FreedomLine™ Automated Transmissions

12-Speed FreedomLine

Transmission Description	Model Number	Torque Rating lb-ft	Overall Ratio		Rev. L	Rev. H	Ratio and Percent Step																						
			FWD.	REV.			1	2	3	4	5	6	7	8	9	10	11	12											
12-Speed Direct Drive	M-13Z12A-A13	1,350	15.86	14.68	14.68	11.41	15.86	29	12.33	29	9.57	29	7.44	27	5.87	28	4.57	32	3.47	28	2.70	29	2.10	29	1.63	26	1.29	29	1.00
	M-14Z12A-A14	1,450																											
12-Speed Overdrive	MO-13Z12A-A13	1,350																											
	MO-14Z12A-A14	1,450	15.81	14.62	11.41	8.88	12.33	29	9.59	29	7.44	29	5.78	26	4.57	29	3.55	31	2.70	29	2.10	29	1.63	28	1.27	27	1.00	28	.78
	MO-15Z12A-A15	1,550																											
	MO-16Z12A-A16	1,650																											

12-Speed FreedomLine — Additional Specifications

Model	Optional Internal Oil Pump	Oil Capacity (pints)	Length (inches)	Weight (lbs.*)	PTO
M-13Z12A-A13	STD.	23.25	31.7	565	Available
M-14Z12A-A14	STD.	23.25	31.7	565	Available
MO-14Z12A-A14	STD.	23.25	31.7	565	Available
MO-15Z12A-A15	STD.	23.25	31.7	565	Available
MO-16Z12A-A16	STD.	23.25	31.7	565	Available

*Weights are approximate, less shift controls, output yoke and lubricant.

16-Speed FreedomLine

Transmission Description	Model Number	Torque Rating lb-ft	Overall Ratio		Rev. L	Rev. H	Ratio and Percent Step																															
			FWD.	REV.			1	2	3	4	5	6	7	8	9	10	11	12	13	14	15	16																
16-Speed Direct Drive	M-13Z16A-A13	1,350																																				
	M-14Z16A-A14	1,450	17.03	15.77	15.77	13.07	17.03	21	14.12	23	11.50	21	9.54	21	7.86	21	6.52	18	5.51	21	4.57	23	3.73	21	3.09	23	2.52	21	2.09	22	1.72	21	1.43	18	1.21	21	1.00	
	M-14Z16A-A15	1,550																																				
	M-16Z16A-A16	1,650																																				
16-Speed Overdrive	MO-13Z16A-A13	1,350																																				
	MO-14Z16A-A14	1,450	17.01	15.75	13.07	10.81	14	12.21	11.68	22	9.54	21	7.89	21	6.52	21	5.39	18	4.57	21	3.78	22	3.09	21	2.56	22	2.09	21	1.73	21	1.43	21	1.18	18	1.00	20	0.83	
	MO-15Z16A-A15	1,550																																				
	MO-16Z16A-A16	1,650																																				

16-Speed FreedomLine — Additional Specifications

Model	Optional Internal Oil Pump	Oil Capacity (pints)	Length (inches)	Weight (lbs.*)	PTO
M-14Z16A-A14	STD.	25.0	33.4	604	Available
M-15Z16A-A15	STD.	25.0	33.4	604	Available
M-16Z16A-A16	STD.	25.0	33.4	604	Available
MO-14Z16A-A14	STD.	25.0	33.4	604	Available
MO-15Z16A-A15	STD.	25.0	33.4	604	Available
MO-16Z16A-A16	STD.	25.0	33.4	604	Available

*Weights are approximate, less shift controls, output yoke and lubricant.

Section 11

Transmissions

Platform "F" Manual Transmission Oil Capacities ①

Model	Oil Capacity (Pints)	Length (In.)	Weight (Lbs.)	PTO (% of Engine)
RM9-115A ③	20.0	28.9	588	75.8
RM9-125A ③	20.0	28.9	588	75.8
RM9-135A ③	20.5	29.5	605	75.8
RM9-145A ③	20.5	29.5	605	75.8
RM9-155A ③	20.5	29.5	608	75.8
RMO9-125A	20.0	28.9	588	101.7
RMO9-135A	20.5	29.5	605	101.7
RMO9-145A	20.5	29.5	605	101.7
RMX9-125A ③	20.0	28.9	588	101.7
RMX9-135A ③	20.5	29.5	605	101.7
RMX9-145A ③	20.5	29.5	605	101.7
RMO9-115B	20.0	28.9	588	87.1
RMO9-125B	20.0	28.9	588	87.1
RMO9-135B	20.5	29.5	605	87.1
RMO9-145B	20.5	29.5	605	87.1
RMX9-115B ③	20.0	28.9	588	87.1
RMX9-125B ③	20.0	28.9	588	87.1
RMX9-135B ③	20.5	29.5	605	87.1
RMX9-145B ③	20.5	29.5	605	87.1
RMX9-155B ③	20.5	29.5	608	87.1
RMX9-115R ③	20.0	28.9	588	101.7
RMX9-125R ③	20.0	28.9	588	101.7
RMX9-135R ③	20.5	29.5	605	101.7
RMX9-145R ③	20.5	29.5	605	75.8
RM10-115A ③	20.0	28.9	588	75.8

Model	Oil Capacity (Pints)	Length (In.)	Weight (Lbs.)	PTO (% of Engine)
RM10-125A ③	20.0	28.9	588	75.8
RM10-135A ③	20.5	29.5	605	75.8
RM10-145A ③	20.5	29.5	605	75.8
M-14F10A-M16 ③	20.5	29.5	605	75.8
RM10-155A ③	20.5	29.5	608	75.8
RD10-145A	20.5	29.5	605	75.8
RMX10-115A ③	20.0	28.9	588	101.7
RMX10-125A ③	20.0	28.9	588	101.7
RMX10-135A ③	20.5	29.5	605	101.7
RMX10-145A ③	20.5	29.5	605	101.7
MO-14F10A-M16 ③	20.5	29.5	605	101.7
RMX10-155A ③	20.5	29.5	608	101.7
RMX10-165A ③	20.5	29.5	608	101.7
RMX10-115C ③	20.5	29.5	605	98.2
RMX10-125C ③	20.5	29.5	605	98.2
RMX10-135C ③	20.5	29.5	605	98.2
RMX10-145C ③	20.5	29.5	605	98.2
MO-14F10C-M16 ③	20.5	29.5	605	98.2
RMX10-155C ③	20.5	29.5	608	98.2
RMX10-165C ③	20.5	29.5	608	98.2
MO-16F10C-M18 ③	20.5	29.5	608	98.2
RMO13-145A ③	22.0	32.4	666	75.8

- ① Oil capacities are approximate. Fill the transmission to the bottom of the fill plug hole. On transmissions equipped with an oil pump and/or oil cooler, operate the engine for five minutes after the initial fill and check the oil level again.
- ② Weights are approximate, less clutch housing, shift controls, output yoke and lubricant.
- ③ Available with Meritor's Engine Synchro Shift™ (ESS™) System. For ESS transmission models, replace the "M" in the above model numbers with an "S".

WARNING

To prevent serious eye injury, always wear safe eye protection when you perform vehicle maintenance or service.

Wheel Bearings

Grease the Bearings

WARNING

Park the vehicle on a level surface. Block the wheels to prevent the vehicle from moving. Support the vehicle with safety stands. Do not work under a vehicle only supported by jacks. Jacks can slip or fall over and cause serious personal injury.

1. Raise the vehicle so that the wheels are off the ground. Support the vehicle with safety stands.
2. Remove the tire and wheel assembly. Remove and disassemble the hub.
3. Use the correct cleaning solvent to remove the old grease from all parts. Discard the seals. Inspect the wheel bearings for wear or damage. Replace worn or damaged bearings.
4. Before installing the wheel bearings, lubricate the bearing journals on the spindle with the grease that is used for the bearings.
Figure 12.1.
5. Use a pressure packer to force the specified grease from the large end of the cones into the cavities between the rollers and cage. Pack the hub between the bearing cups with grease to the level of the smallest diameter of the cups.
 - **If a pressure packer is not available:** Grease the bearings by hand.
6. Install the inner and outer bearing cones into the cups in the hubs. The bearing cups must be pressed tight against the shoulder in the hubs.
7. Install new wheel seals in the hubs.
8. Install the hub and the wheel and tire assembly. Install the outer wheel bearing cone in the hub. Install the adjusting nut.
9. Adjust the wheel bearings.

Figure 12.1

TYPICAL GREASE-LUBRICATED WHEEL BEARINGS

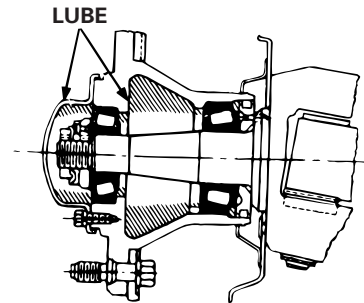

Check the Oil Level

NOTE: If you cannot observe the oil level because the sightglass is stained, remove the fill plug, check the oil level with your finger and follow the procedures for Step 2, below. Replace the stained sightglass as soon as possible.

1. Check the oil level on the cap.
2. If the oil level is more than 1/4-inch (6 mm) below the specified level on the cap, remove the fill plug.
3. Add the specified oil to the specified level.
Figure 12.2.
4. Install the fill plug.

Figure 12.2

TYPICAL OIL-LUBRICATED WHEEL BEARINGS

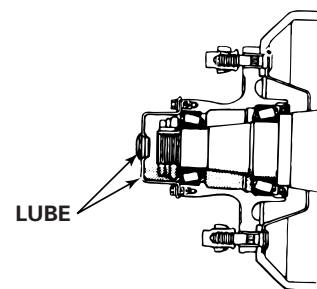

Section 12

Wheel Bearings and Wheel-Ends

Drive Axle Hubs Without Fill Holes

1. Add the specified amount of lubricant through the carrier or housing bowl oil fill hole.
2. Tilt the axle to the right and to the left to let the oil flow into the hub cavities. Keep the axle tilted for one minute in each position.
3. With the axle in the level position, add the specified oil so that the level is even with the bottom of the fill plug hole.
4. Install and tighten the fill plug.

Wheel-End Axle Greasing Intervals and Specifications

Greasing Interval	Grease	RICO Specification	NLGI Grade	Grease Description	Outside Temperature
Whichever comes first: Replacing Seals Relining Brakes On-Highway: 30,000 miles (48 000 km) On/Off Highway and Off-Highway: Twice a year	Multi-Purpose Grease	O-617-A (preferred) or O-617-B (acceptable)	1 or 2	Lithium 12-Hydroxy Stearate or Lithium Complex	Refer to the grease manufacturer's specifications for the temperature service limits.

Wheel-End Oil Change Intervals and Specifications

Operation	On-Highway	Off-Highway
Check Oil Level	1,000 miles (1600 km)	1,000 miles (1600 km)
Petroleum Oil Change	Whichever comes first. Seals replaced. Brakes relined. 100,000 miles (160 000 km). Once a year.	Whichever comes first. Seals replaced. Brakes relined. Once a year.
Synthetic Oil Change	—	—

RICO Specifications	Military/SAE Specifications	Oil Description	Outside Temperature			
			°F		°C	
			Min.	Max.	Min.	Max.
O-76A Gear Oil	MIL-PRF-2105-E and SAE J2360	GL-5, SAE 85W/140	10	None	-12	None
O-76D Gear Oil		GL-5, SAE 80W/90	-15	None	-26	None
O-76E Gear Oil		GL-5, SAE 75W/90	-40	None	-40	None
O-76J Gear Oil		GL-5, SAE 75	-40	35	-40	2
Heavy-Duty Engine Oil	MIL-L-2104 E or F	A.P.I. -CD, -CE, -SG, -SH or -SJ SAE 40 or 50 ①	10	None	-12	None
Heavy-Duty Engine Oil	MIL-L-210 E or F	A.P.I. -CD, -CE, -SG, -SH or -SJ SAE 30 ②	-15	None	-26	None

① Current designations are acceptable. Multi-grade engine oils are acceptable if the SAE rating ends in 40 or 50.

② Current designations are acceptable. Multi-grade engine oils are acceptable if the SAE rating ends in 30.

Section 13 List of Lubricants

Grease Lubricants^①

RICO Specification	Grease	Typical Application	NLGI Grade	Grease Description	Outside Temperature
O-616	Brake Grease	Cam Brake Anchor Pins, Mechanical Brake Anchor Pins	2	Clay Base	②
O-616-A	Brake Grease	Air Disc Brake Caliper, Automatic Slack Adjuster, Wedge Brake Components	1	Clay Base	Down to -40°F (-40°C)
O-617-A or O-617-B	Multi-Purpose Grease	Cam Brake Chamber Brackets, Cam Brake Hold Down Clips, Cross Tube Ends, Drag Link, Wheel Bearings, King Pins and Bushings, Knuckle Bushings, Manual Slack Adjuster, Steering Arm, Ball Studs, Tie Rod End Ball Studs, Trailer Axle Wheel Bearings, Wedge Brake Hold-Down Clips, Wedge Brake Shoe Contacts at Anchors.	1 or 2	Lithium 12-Hydroxy Stearate or Lithium Complex	②
O-634-B	Universal Joint Grease	Driveshaft Slip Yokes, Driveshaft Splines, Driveshaft Universal Joints	2	Lithium 12-Hydroxy Stearate with Molybdenum Disulfide	②
O-637 ^③	Special Rust-Preventing Brake Grease	Air Disc Brake Slide Pin, Splines and Clevis Pins, Cam Brake Camshaft Splines	1-1/2	Calcium	②
O-645	Low-Temperature Brake Grease	Air Disc Brake Caliper, Automatic Slack Adjuster, Wedge Brake Components	2	Synthetic	Down to -65°F (-54°C)
O-647	Trailer Axle Bearing Grease	Trailer Axle Wheel Bearings	00	Synthetic	②
O-661	High-Temperature Multi-Purpose Wheel Bearing Grease	Clutch Release Bearing	3	Lithium Complex	②
O-692	Automatic Slack Adjuster Grease	Automatic Slack Adjuster	1 & 2	Lithium Base	Down to -40°F (-40°C)

① Grease recommendations are based on commercial products that have given satisfactory results in normal operation. However, there are many proprietary grease products on the market which will perform satisfactorily and may be preferable because of supply problems, common usage for other truck components, etc. When such products are recommended by reputable suppliers for the specific lubrication of our components, RICO has no objections, provided that these substitute products are equal to or better than RICO recommendations in lubrication properties, water resistance, corrosion protection, high and low temperature characteristics, oxidation stability, shear stability, etc. All substitute products are subject to RICO approval. For more information, contact an ArvinMeritor service representative.

② Refer to the manufacturer's specifications for the temperature service limits.

③ Do not mix O-637 calcium-base, corrosion-control grease with other greases.

Section 13

List of Lubricants

Oil Lubricants

RICO Specification	Oil	Typical Application	Military/SAE Specifications	Oil Description	Outside Temperature			
					°F		°C	
					Min.	Max.	Min.	Max.
O-62	Petroleum Oil	Transfer Case	—	SAE 90	10	None	-12	None
O-63	Petroleum Oil	Transfer Case	—	SAE 140	40	None	4	None
O-76A	Gear Oil	Front Driving Axle, Front Driving Axle Wheel Bearings, Non-Driving Axle Wheel Bearings, Planetary Axle, Rear Driving Axle, Trailer Axle Wheel Bearings	MIL-PRF-2105-E and SAE J2360	GL-5 SAE 85W/140	10	None	-12	None
O-76D	Gear Oil	Front Driving Axle, Front Driving Axle Wheel Bearings, Non-Driving Axle Wheel Bearings, Planetary Axle, Rear Driving Axle, Trailer Axle Wheel Bearings		GL-5 SAE 80W/90	-15	None	-26	None
O76E	Gear Oil	Front Driving Axle, Front Driving Axle Wheel Bearings, Non-Driving Axle Wheel Bearings, Planetary Axle, Rear Driving Axle, Trailer Axle Wheel Bearings		GL-5 SAE 75W/90	-40	None	-40	None
O-76J	Gear Oil	Front Driving Axle, Front Driving Axle Wheel Bearings, Non-Driving Axle Wheel Bearings, Planetary Axle, Rear Driving Axle, Trailer Axle Wheel Bearings		GL-5 SAE 75W	-40	35	-40	2
O-76L	Gear Oil	Front Driving Axle, Front Driving Axle Wheel Bearings, Non-Driving Axle Wheel Bearings, Planetary Axle, Rear Driving Axle, Trailer Axle Wheel Bearings		GL-5 SAE 75W/140	-40	None	-40	None
O-76M	Full Synthetic Oil	Rear Driving Axle, Trailer Axle Wheel Bearings		GL-5 SAE 75W/140	-40	None	-40	None
O-76N	Full Synthetic Oil	Rear Driving Axle, Trailer Axle Wheel Bearings		GL-5 SAE 75W/90	-40	None	-40	None
O-81	Full Synthetic Oil	Transmission		—	SAE 50	-40	None	-40
—	Heavy Duty Engine Oil	Transmission	MIL-L-2104 -E or -F*	A.P.I. -CD, -CE, -SG, -SH or -SJ; SAE 50*	10	None	-12	None
—	Heavy Duty Engine Oil	Transmission		A.P.I. -CD, -CE, -SG, -SH or -SJ; SAE 40*	10	None	-12	None
—	Heavy Duty Engine Oil	Transmission		A.P.I. -CD, -CE, -SG, -SH or -SJ; SAE 30*	-15	10	-26	-12
—	Petroleum Gear	Transmission		A.P.I.-GL-1; SAE 90	10	None	-12	None
—	Petroleum Gear	Transmission		A.P.I.-GL-1; SAE 80	-15	None	-26	None

* Current designations are acceptable.