

REVISIONS				
ZONE	REV.	DESCRIPTION	DATE	APPV

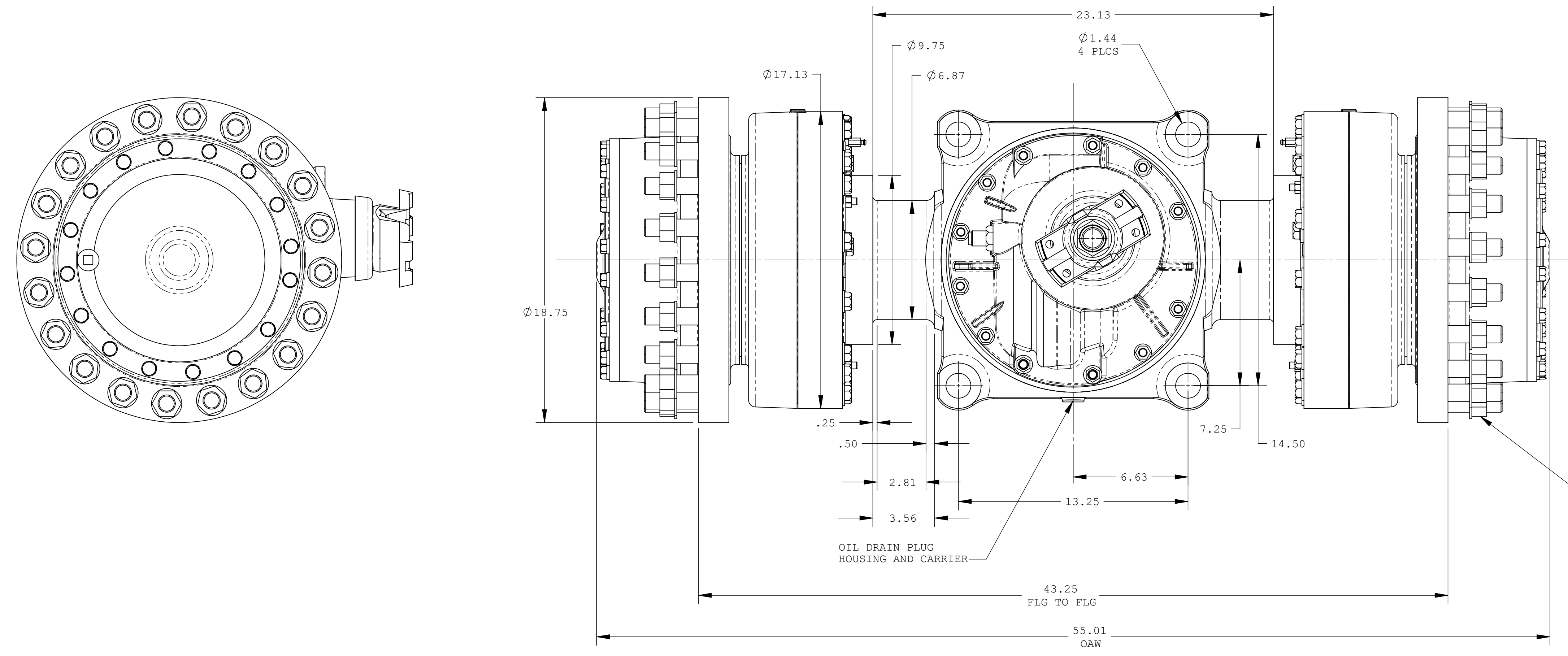
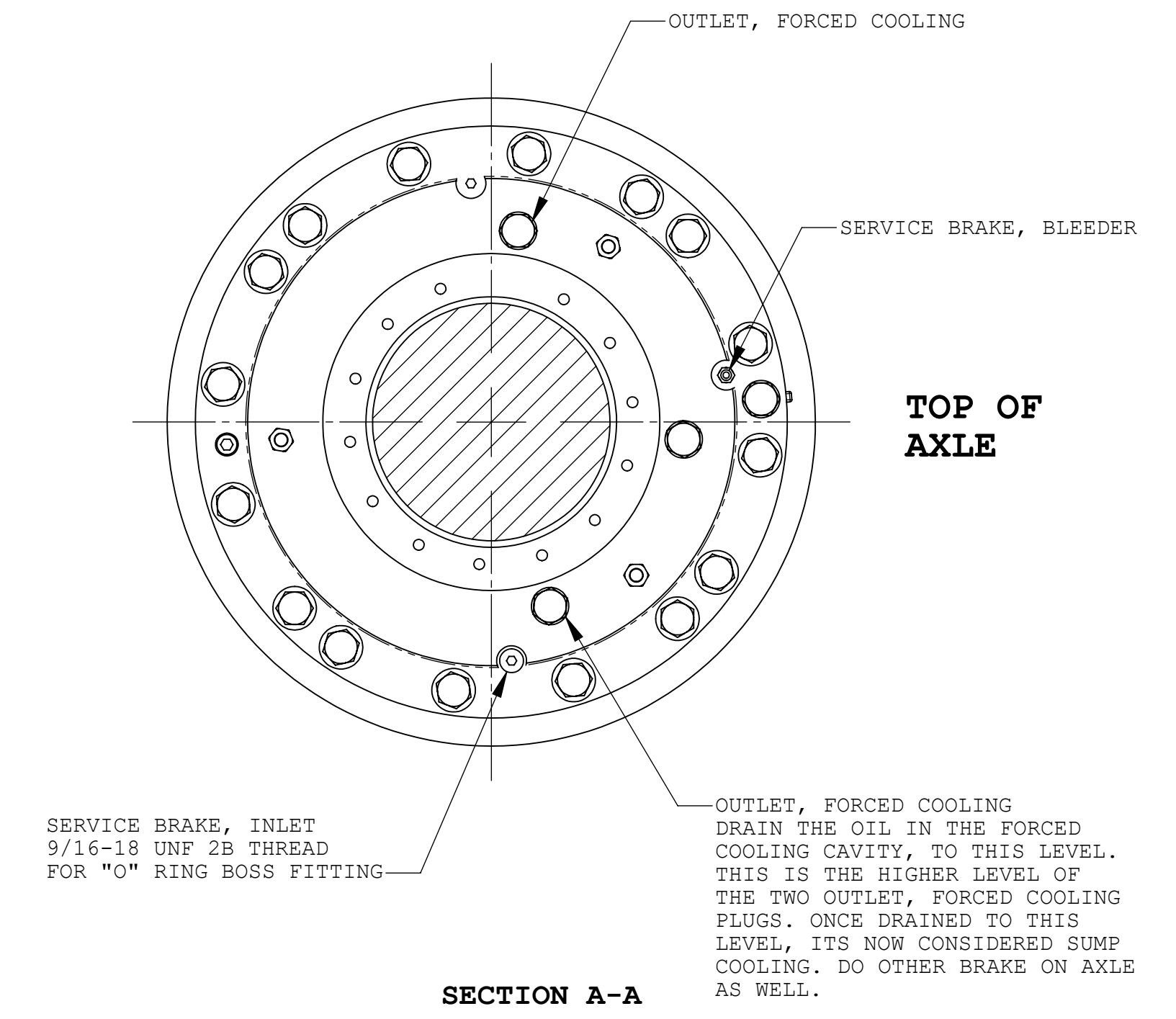
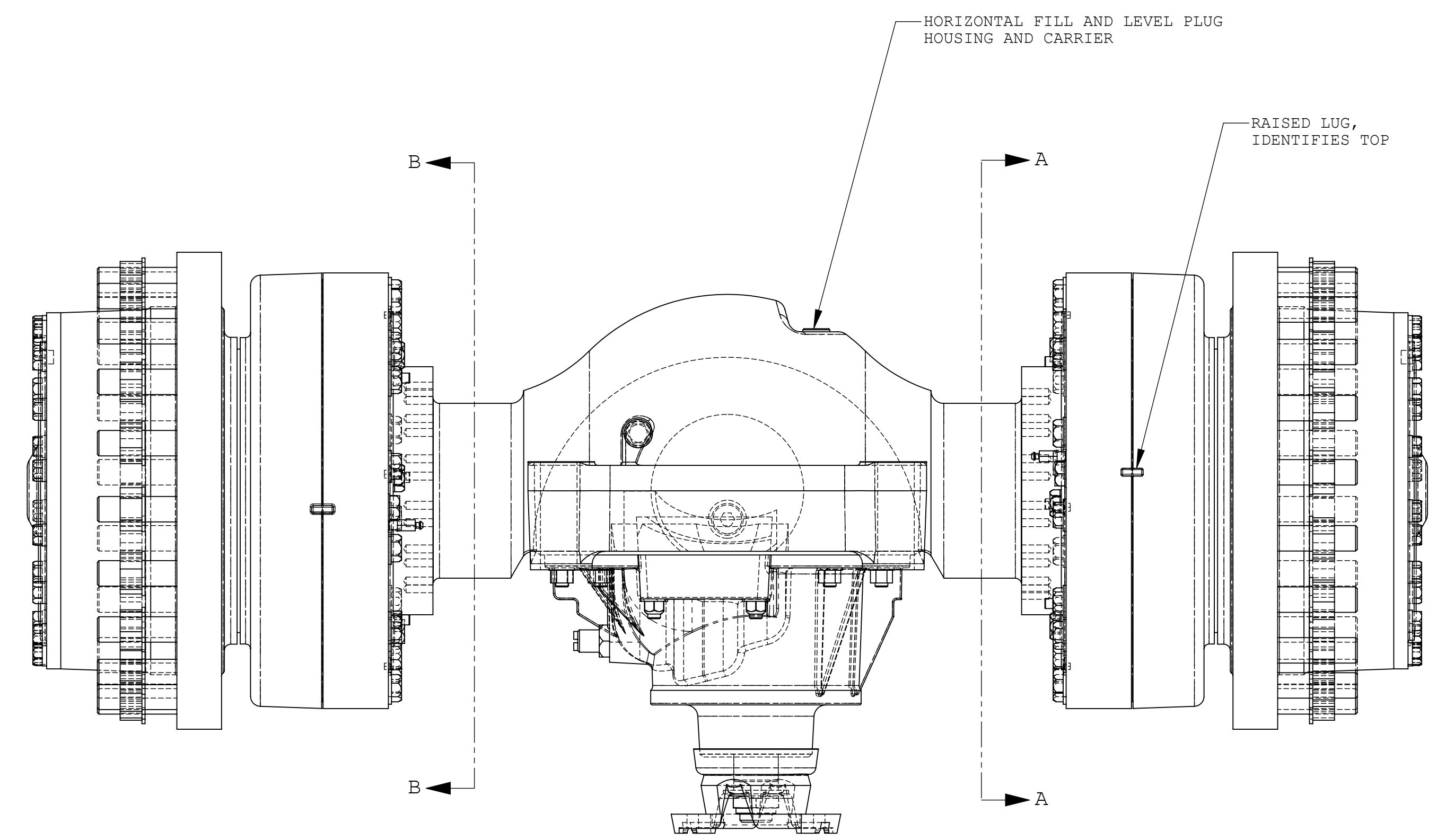
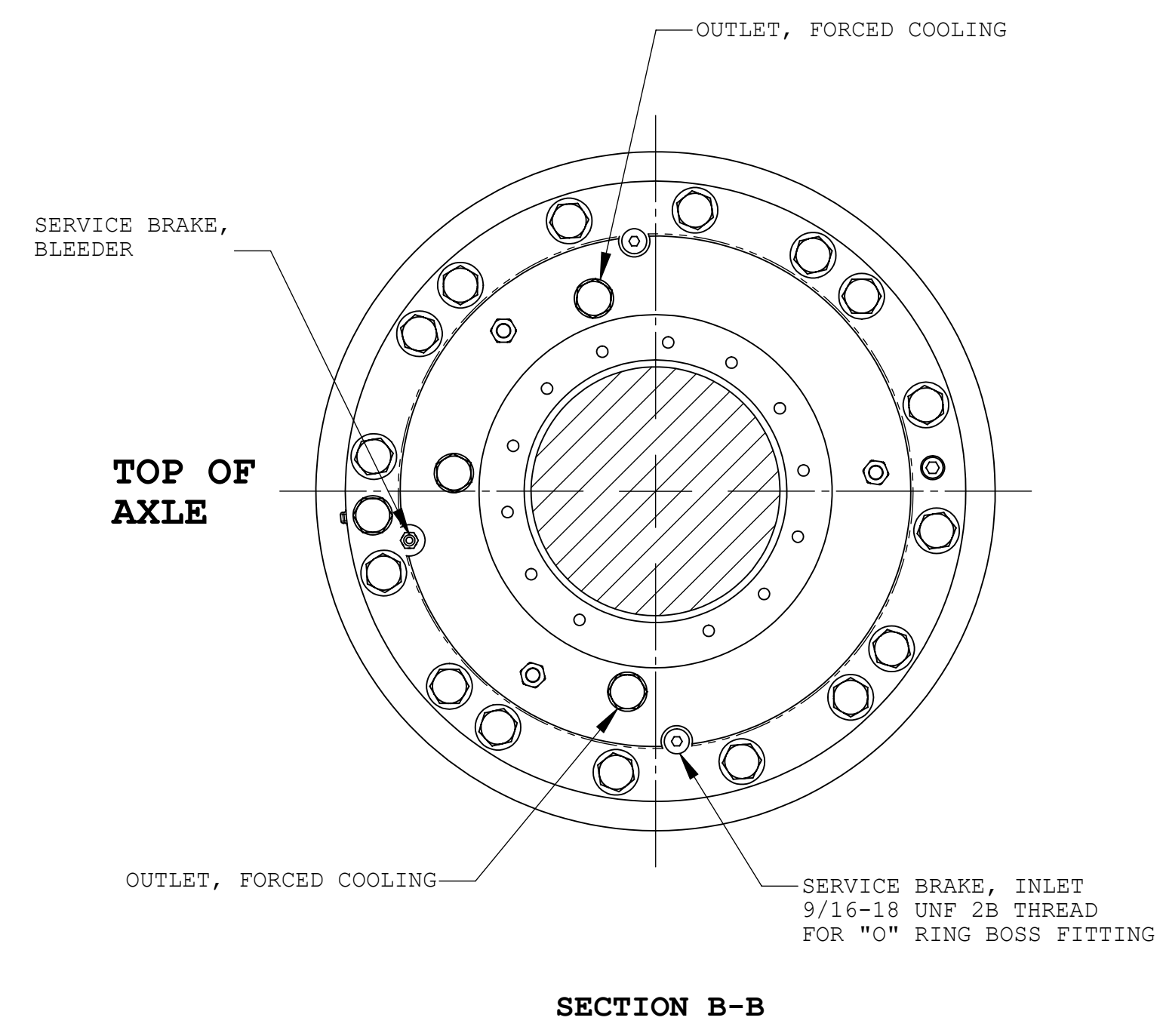

ITEM	QTY	DRAWING NO.	DESCRIPTION
1	1		
<p>This drawing contains proprietary information. This drawing or any part of it shall not be reproduced in any manner except as authorized in writing.</p>			
<p>TOLERANCES UNLESS OTHERWISE SPECIFIED</p> <p>DECIMAL .1 ±.01</p> <p>XX ±.04</p> <p>XXX ±.010</p>		<p>RICO</p> <p>PLANETARY DRIVE AXLE ASSY - 30.36:1</p>	
<p>SIZE: B</p> <p>ANGULAR ±1°</p>		<p>DRAWN BY: MWR</p> <p>DATE: 09/16/2020</p>	<p>SCALE: 1:4</p> <p>SHEET 1 OF 1</p>