

REVISIONS				
ZONE	REV.	DESCRIPTION	DATE	APPROVED
	A	ADDED NOTE TO SHEET 2	8/9/2017	JRF

DESIGNATOR	PART NUMBER	DESCRIPTION	TERMINALS	NOTES
A1	284742-1	AMP 60-POSITION HOUSING	SEE NOTE 6	NOTE 6
A2	282080-1	AMP SUPERSEAL 1.5 SERIES - 2 POSITION	183025-1 (AMP)	NOTE 3
A3	827551-3	AMP JUNIOR TIMER - 2 POSITION	925590-1 (AMP)	NOTE 5
D1	12065287	DELPHI METRI-PACK 150 - 3 POSITION	12103881 (TERMINAL SUPPLY)	NOTE 1
D2*	DT06-2S	DEUTSCH - 2 POSITION	0462-201-16141 (TERMINAL SUPPLY)	NOTE 4
D3*	DT06-2S	DEUTSCH - 2 POSITION	0462-201-16141 (TERMINAL SUPPLY)	NOTE 4
D4*	DT06-2S	DEUTSCH - 2 POSITION	0462-201-16141 (TERMINAL SUPPLY)	NOTE 4
D5*	DT06-2S	DEUTSCH - 2 POSITION	0462-201-16141 (TERMINAL SUPPLY)	NOTE 4
D6**	DT06-3S	DEUTSCH - 3 POSITION	0462-201-16141 (TERMINAL SUPPLY)	NOTE 4
W1	12015791	WEATHERPACK TOWER - 1 POSITION	12089188 (TERMINAL SUPPLY)	NOTE # 2
W2	12010975	WEATHERPACK SHROUD - 6 POSITION	12124582 (TERMINAL SUPPLY)	NOTE # 2
W3	12015793	WEATHERPACK TOWER - 3 POSITION	12089188 (TERMINAL SUPPLY)	NOTE # 2
W4	12010974	WEATHERPACK SHROUD - 4 POSITION	12089040 (TERMINAL SUPPLY)	NOTE # 2
W5	12015797	WEATHERPACK TOWER - 4 POSITION	12089188 (TERMINAL SUPPLY)	NOTE # 2
W6	12015797	WEATHERPACK TOWER - 4 POSITION	12089188 (TERMINAL SUPPLY)	NOTE # 2
W7	12015792	WEATHERPACK TOWER - 2 POSITION	12124580 (TERMINAL SUPPLY)	NOTE # 2
W8	12010974	WEATHERPACK SHROUD - 4 POSITION	12089040 (TERMINAL SUPPLY)	NOTE # 2
W9	12015792	WEATHERPACK TOWER - 2 POSITION	12124580 (TERMINAL SUPPLY)	NOTE # 2

NOTE #1- CRIMP TOOL- 12155975. REMOVAL TOOL- 12094429. (TERMINAL SUPPLY)
 NOTE #2- CRIMP TOOL- 12014254. REMOVAL TOOL- 12014012. INSERTION TOOL- 12033495. (TERMINAL SUPPLY)
 NOTE #3- CRIMP TOOL- 58583-1. REMOVAL TOOL- 9-1579007-1. (TE CONNECTIVITY)
 NOTE #4- CRIMP TOOL- HDT-48-00. REMOVAL TOOL- 0411-310-1605. (TERMINAL SUPPLY)
 NOTE #5- CRIMP TOOL- 539635-1 REMOVAL TOOL- 725864-1. (TE CONNECTIVITY)
 NOTE #6- A1 - 60 PIN CONNECTOR USES TWO DIFFERENT TERMINALS (16 AWG & 20 AWG)

AMP - 16 AWG - 1241608-1 (PINS 1-5, 15-20, 30-35, 45-50, 60)
 CRIMP TOOL- 539635-1, REMOVAL TOOL 6-1579007-2 (TE CONNECTIVITY)

AMP - 20 AWG - 968221-1 (PINS 6-14, 21-29, 36-44, 51-59)
 CRIMP TOOL- 539-635-1, REMOVAL TOOL 6-1579007-0 (TE CONNECTIVITY)

* WEDGELock W2S IS REQUIRED FOR THE D2, D3, D4, AND D5 CONNECTORS
 ** WEDGELock W3S IS REQUIRED FOR THE D6 CONNECTOR

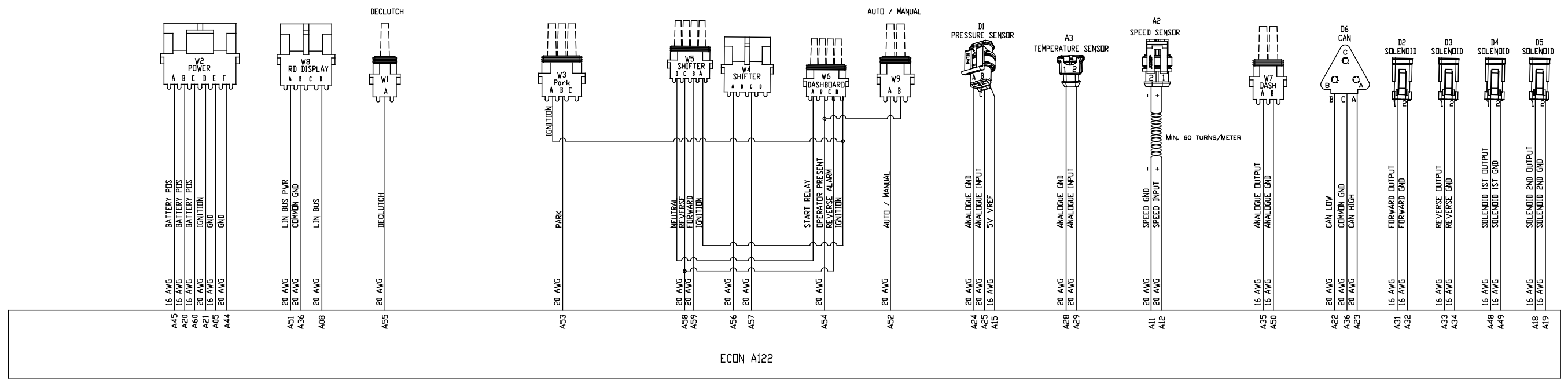

A1 - 60 WAY CONNECTOR

NOTE: SEE SHEET 2 FOR WIRE LENGTHS AND LAYOUT.

UNLESS OTHERWISE SPECIFIED DIMENSIONS ARE GIVEN IN INCHES.					
DISTANCE TOLERANCES: .X ± .1" .XX ± .04" .XXX ± .010"	ANGULAR TOLERANCE: ±1° FRACTIONAL TOLERANCE: ±1/8"			TITLE WIRE HARNESS, TCU	
This drawing contains proprietary information. This drawing or any part of it shall not be reproduced in any manner except as authorized in writing by BPR/Rico Inc.		THIRD ANGLE PROJECTION 	SIZE D	PROCESS ASSY	DWG NO. 11980293-A
SCALE NTS	DRAWN BY JRF	DATE 06/07/16	SHEET 1 of 2		

REVISIONS				
ZONE	REV.	DESCRIPTION	DATE	APPROVED
		SEE SHEET 1 FOR REVISIONS		

FROM BRANCH	DIMENSION	TO BRANCH	TO END OF BRAID	CONN PDS	FROM END OF BRAID TO CONNECTOR
1	N/A	N/A	N/A	1/1	6.25-8.25
1	39	2	N/A	N/A	N/A
1	39	3	N/A	N/A	N/A
1	39	4	N/A	N/A	N/A
1	39	5	N/A	N/A	N/A
1	39	6	N/A	N/A	N/A
1	39	7	N/A	N/A	N/A
1	39	8	N/A	N/A	N/A
2	N/A	N/A	7.5	2/1	2.5
3	N/A	N/A	8.5	3/1	2.5
4	N/A	N/A	24.5	4/1	2.5
5	N/A	N/A	26.0	5/1	5.0
5	N/A	N/A	26.0	5/2	5.0
5	N/A	N/A	26.0	5/3	5.0
5	N/A	N/A	26.0	5/4	5.0
6	N/A	N/A	31.0	6/1	5.0
6	N/A	N/A	31.0	6/2	5.0
7	N/A	N/A	36.5	7/1	2.5
7	N/A	N/A	36.5	7/2	2.5
8	N/A	N/A	126.0	8/1	5.0
8	N/A	N/A	126.0	8/2	5.0
8	N/A	N/A	126.0	8/3	5.0
8	N/A	N/A	126.0	8/4	5.0
8	N/A	N/A	126.0	8/5	5.0
8	N/A	N/A	126.0	8/6	5.0

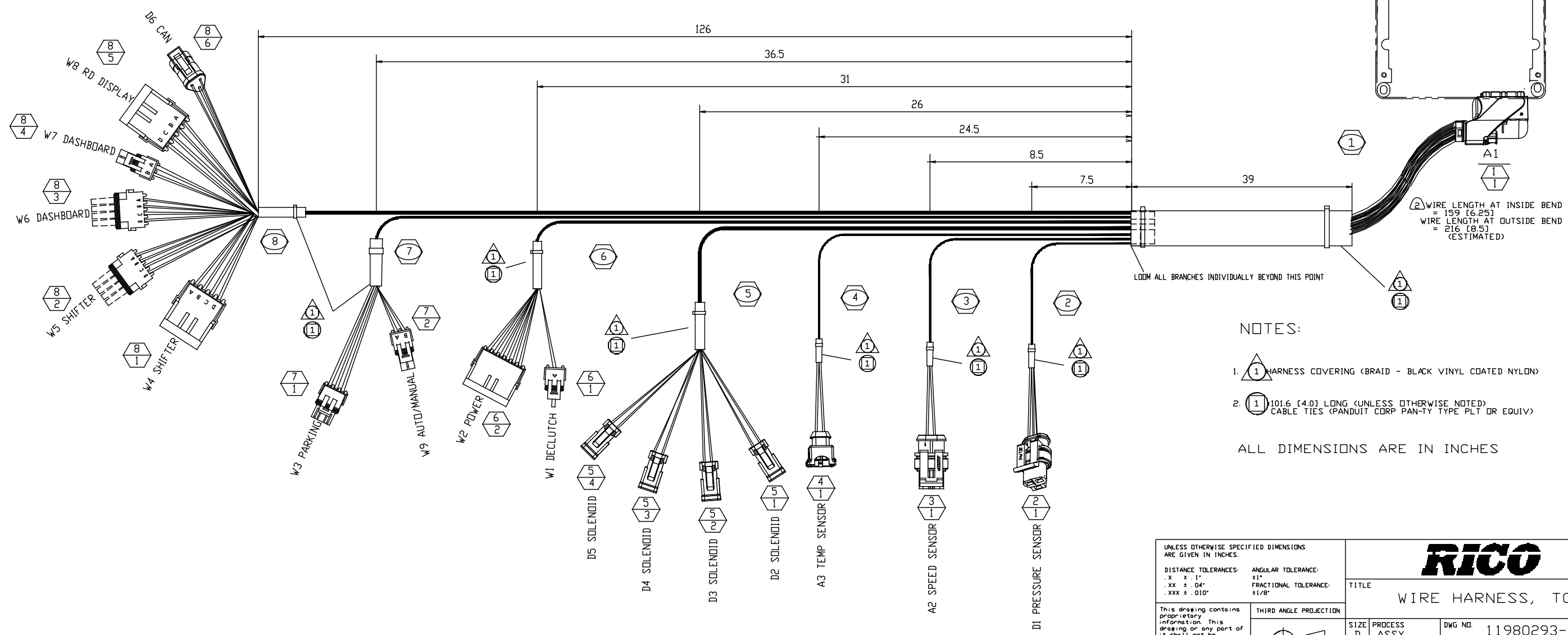

- NOTES:
- ① HARNESS COVERING (BRAID - BLACK VINYL COATED NYLON)
 - ① 101.6 [4.0] LONG (UNLESS OTHERWISE NOTED) CABLE TIES (PANDUIT CORP PAN-TY TYPE PLT OR EQUIV)

ALL DIMENSIONS ARE IN INCHES

UNLESS OTHERWISE SPECIFIED DIMENSIONS ARE GIVEN IN INCHES.			
DISTANCE TOLERANCES: .X ± .1" .XX ± .04" .XXX ± .010"	ANGULAR TOLERANCE: ±1° FRACTIONAL TOLERANCE: ±1/8"		
This drawing contains proprietary information. This drawing or any part of it shall not be reproduced in any manner except as authorized in writing by BPR/Rico Inc.		THIRD ANGLE PROJECTION 	SIZE D SCALE NTS
PROCESS ASSY		DWG NO. 11980293-A	DATE 06/07/16
DRAWN BY JRF		SHEET 2 of 2	