

---

---

# MANUAL

---

---

---

**CURTIS**PMC

MODEL **1204/5**  
MOTOR CONTROLLERS

---

© 1999 CURTIS INSTRUMENTS, INC.

DESIGN OF CURTIS 1200 SERIES  
CONTROLLERS PROTECTED BY U.S.  
PATENT NO. 4626750.

**CURTIS**

**CURTIS PMC**

235 East Airway Boulevard  
Livermore, California 94568 USA  
Tel: 925-961-1088  
Fax: 925-961-1099  
[www.curtisinst.com](http://www.curtisinst.com)

1204 / 1205 Manual  
p/n 98690, Rev. B: May 1999

1204 / 1205 Manual  
p/n 98690, Rev. B: May 1999

© 1999 CURTIS INSTRUMENTS, INC.

This electronic version of the 1204/1205 manual is offered as a convenience to our customers. You may download any or all of it.

If you would like a hard copy of the published manual, please order it by part number from the Curtis office nearest you.

The electronic version of the manual is identical to the printed version published in May 1999. Bookmarks have been added to the electronic version to speed the process of going directly to a particular part of the document.

---

**CURTIS INSTRUMENTS, INC.**

200 KISCO AVENUE  
MOUNT KISCO, NEW YORK 10549 USA  
☎ 914-666-2971 FAX 914-666-2188

■ **CURTIS PMC**

235 EAST AIRWAY BOULEVARD  
LIVERMORE, CALIFORNIA 94550 USA  
☎ 925-961-1088 FAX 925-961-1099

■ **ADDITIONAL OFFICES** *located in*  
*Bulgaria, China, England, France, Germany,*  
*India, Italy, Japan, Netherlands, Puerto Rico,*  
*Russia, Sweden, and Switzerland*

# CONTENTS

1. OVERVIEW .....	1
2. HARDWARE INSTALLATION .....	3
Controller .....	3
Throttle .....	4
Other Hardware .....	6
Main contactor .....	7
Forward/reverse contactors .....	7
Forward/reverse switches .....	7
Keyswitch .....	8
Polarity protection diode .....	8
Control wiring fuse .....	8
Power wiring fuse .....	8
3. WIRING .....	9
Connections: Low Current .....	9
Connections: High Current .....	9
Wiring: Series Motors .....	10
KSI .....	10
Forward/reverse (with standard power wiring) ...	11
Plug braking .....	11
Freewheeling .....	11
Forward/reverse (with alternate power wiring) ...	12
Reversing with 4×SPDT contactors .....	12
Mechanical reversing switch .....	13
Throttle pot .....	14
Standard potbox .....	14
Pots for twist-grip throttles .....	14
Reduced speed operation .....	15
Electronic throttle .....	16
Wiring: Permanent Magnet Motors .....	17
Installation Checkout .....	20
4. MAINTENANCE AND ADJUSTMENT .....	22
Controller .....	22
Potbox .....	24

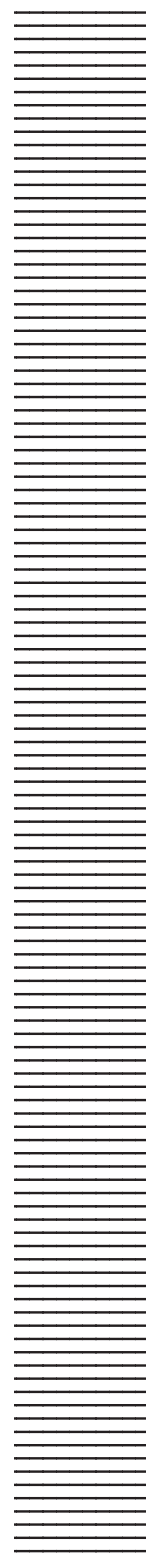

=====	5. TROUBLESHOOTING AND BENCH TESTING .....	25
=====	Operational Notes .....	25
=====	In-Vehicle Diagnostic Tests .....	28
=====	Bench Testing .....	32
=====	6. GLOSSARY: FEATURES AND FUNCTIONS .....	35
=====		
=====	<b>APPENDIXES</b>	
=====	A. Functional Description of 1204/1205 Controllers .....	A-1
=====	B. Pulse Width Modulation .....	B-1
=====	C. Specifications .....	C-1

---

## FIGURES

<b>FIG. 1</b>	Curtis PMC 1205 electronic motor controller .....	1
<b>FIG. 2</b>	Mounting dimensions, Curtis PMC 1204/1205 controller .....	3
<b>FIG. 3</b>	Mounting dimensions, Curtis PMC potboxes PB-5, -6, -9, and -10 .....	5
<b>FIG. 4</b>	Curtis PMC footpedal FP-2 .....	5
<b>FIG. 5</b>	Typical installation, Curtis PMC 1204/1205 controller .....	6
<b>FIG. 6</b>	Basic wiring for use with series motors .....	10
<b>FIG. 7</b>	Alternate control wiring, to provide freewheeling .....	11
<b>FIG. 8</b>	Alternate power wiring, for reversing with 4×SPST contactors .....	12
<b>FIG. 9</b>	Alternate power wiring, for reversing with mechanical forward/reverse switch arm .....	13
<b>FIG. 10</b>	Standard throttle pot, 0–5k $\Omega$ .....	14
<b>FIG. 11</b>	Bi-directional twist-grip throttle with 10 k $\Omega$ center-tapped, 4-terminal pot .....	14
<b>FIG. 12</b>	Bi-directional twist-grip throttle with 20 k $\Omega$ pot and controller with optional 5k $\Omega$ –0 throttle input .....	15
<b>FIG. 13</b>	Reduced speed operation (with standard 0–5k $\Omega$ pot) ....	15
<b>FIG. 14</b>	Curtis PMC electronic throttle (ET series) .....	16
<b>FIG. 15</b>	Basic wiring for use with permanent magnet (PM) motors .....	17

<b>FIG. 16</b>	Alternate PM motor wiring, using 4×SPST contactors to provide freewheeling.....	18
<b>FIG. 17</b>	Preferred PM motor wiring for freewheeling or dynamic braking .....	18
<b>FIG. 18</b>	Adjustment pots .....	23
<b>FIG. 19</b>	Guide to troubleshooting procedures.....	27
<b>FIG. 20</b>	Setup for bench testing .....	33
<b>FIG. A-1</b>	Block diagram, Curtis PMC 1204/1205 controller .....	A-1
<b>FIG. B-1</b>	Pulse width modulation .....	B-1

## 1

## OVERVIEW

Curtis PMC Model 1204 and 1205 electronic motor speed controllers are designed to provide smooth, silent, cost-effective control of motor speed and torque on a wide variety of industrial electric vehicles.

**Fig. 1** *Curtis PMC 1205 electronic motor controller.*

*Model 1204 has identical connections.*



Like all Curtis PMC 1200 series controllers, the 1204/1205 models offer superior operator control of the vehicle's motor drive speed. Key features of the 1204/1205 controllers include:

- ✓ Infinitely variable drive and brake control
- ✓ Power MOSFET design provides high efficiency (for reduced motor and battery losses) and silent operation
- ✓ High pedal disable (HPD) function monitors throttle status during turn-on and prevents operation until throttle has been returned to neutral *[optional feature]*
- ✓ Thermal protection and compensation circuit provides both under-temperature and overtemperature cutback, as well as steady current limit throughout the entire operating range
- ✓ Undervoltage cutback function protects against low battery voltage, including low voltage caused by external loads

*More Features* 

- ✓ Pot fault circuit shuts off controller if pot wires open
- ✓ Simple installation with no adjustments required
- ✓ Tin-plated solid copper bus bars
- ✓ Push-on connectors for control wiring

Familiarity with your Curtis PMC controller will help you to install and operate it properly. We encourage you to read this manual carefully. If you have questions, please contact the Curtis office nearest you.

**CAUTION**

**Working on electric vehicles is potentially dangerous.** You should protect yourself against runaways, high current arcs, and outgassing from lead acid batteries:

**RUNAWAYS** — Some fault conditions could cause the vehicle to run out of control. Jack up the vehicle and get the drive wheels off the ground before attempting these procedures or any other work on the motor control circuitry.

**HIGH CURRENT ARCS** — Electric vehicle batteries can supply very high power, and arcs can occur if they are short circuited. Always open the battery circuit before working on the motor control circuit. Wear safety glasses, and use properly insulated tools to prevent shorts.

**LEAD ACID BATTERIES** — Charging or discharging generates hydrogen gas, which can build up in and around the batteries. Follow the battery manufacturer's safety recommendations. Wear safety glasses.



## 2

## HARDWARE INSTALLATION

## CONTROLLER

The controller may be oriented in any position, but **the location should be carefully chosen to keep the controller as clean and dry as possible. If a clean, dry mounting location cannot be found, a cover must be used to deflect dirt and water splash.**

The controller should be fastened with four screws to a clean, flat metal surface that provides an adequate heat sink. The mounting surface is an integral part of the overall heatsinking of the controller, and affects its ability to dissipate heat. The case outline and mounting hole dimensions are shown in Figure 2. If your controller is an adjustable model, be sure to mount it so as to allow access to the adjustment screws.

Although not usually necessary, a thermal joint compound can be used to improve heat conduction from the case to the mounting surface.

**Fig. 2** *Mounting dimensions, Curtis PMC 1204/5 controller.*

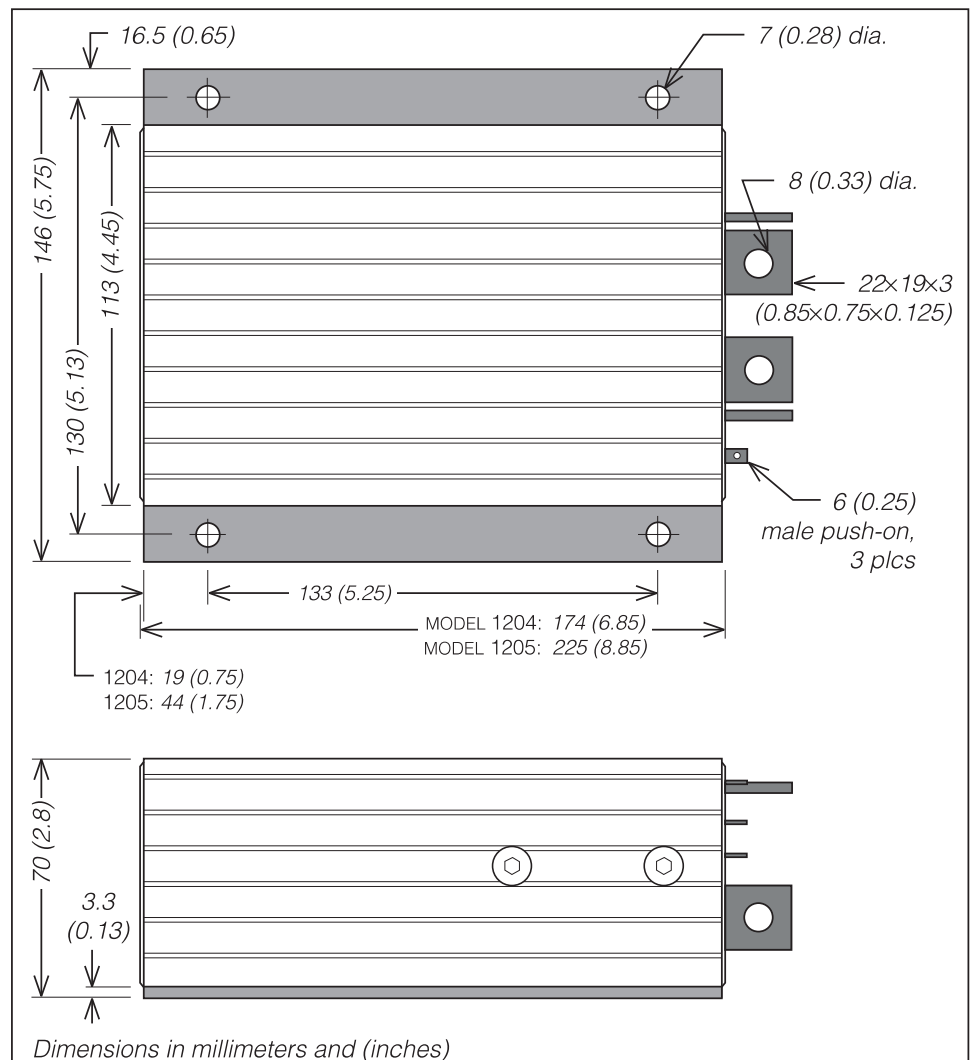

## THROTTLE

The standard controller throttle input is 0–5k $\Omega$ . Curtis PMC potboxes (PB-5, -6, -9, -10) are designed to match this input. Some of these potboxes have a built-in microswitch, eliminating the need to install a separate pedal-actuated microswitch. Curtis PMC also offers a self-contained footpedal unit (FP-2) that eliminates the need for fabricating and installing a pedal-potbox linkage. Any potbox that provides a nominal 0–5k $\Omega$  output (controller output begins at  $\approx$ 300 ohms, full output is  $\approx$ 4400 ohms) will work with the standard throttle input. For other types, contact your Curtis office.

If a Curtis PMC potbox is used, it must be mounted so as to allow connection between the potbox lever arm and the vehicle accelerator linkage. The potbox mounting dimensions are shown in Figure 3. The lever arm provides a series of holes so that the accelerator pedal “throw” can be converted into the correct amount of potentiometer rotation. Use of a second return spring on the pedal, in addition to the potbox return spring, is required to prevent an uncontrollable full-on throttle input (which could happen if there was a single spring, and it broke). If the self-contained potbox spring is insufficient to return the pedal by itself, two additional pedal return springs must be used.

It is also required that the accelerator pedal hit a mechanical stop at its full-on position just before ( $\approx$ 1 mm [1/32"–1/16"]) the potbox lever hits its own full-on stop. This mechanical stop will prevent the potbox lever arm from bending if undue force is put on the pedal. Protection of the potbox from water and dirt will help avoid problems of corrosion and electrical leakage.

After the potbox has been mounted, operation of the pot can be tested by measuring the resistance between the two wires with an ohmmeter. With the pedal not applied, the resistance should be less than 50 ohms. As the pedal is applied, the resistance should rise smoothly until it reaches a value between 4500 and 5500 ohms. Values below 4500 ohms may cause a reduction in efficiency and top speed. Values above 7000 ohms indicate a defective potbox, and will cause controller shutdown.

Curtis PMC’s electronic throttle (ET-XXX), manufactured by Hardellet, is designed for 24–36V systems, and can be used with any 1204/1205 controller having the 0–5V throttle input option.

**Fig. 3** Mounting dimensions, Curtis PMC potboxes PB-5, -6, -9, and -10.

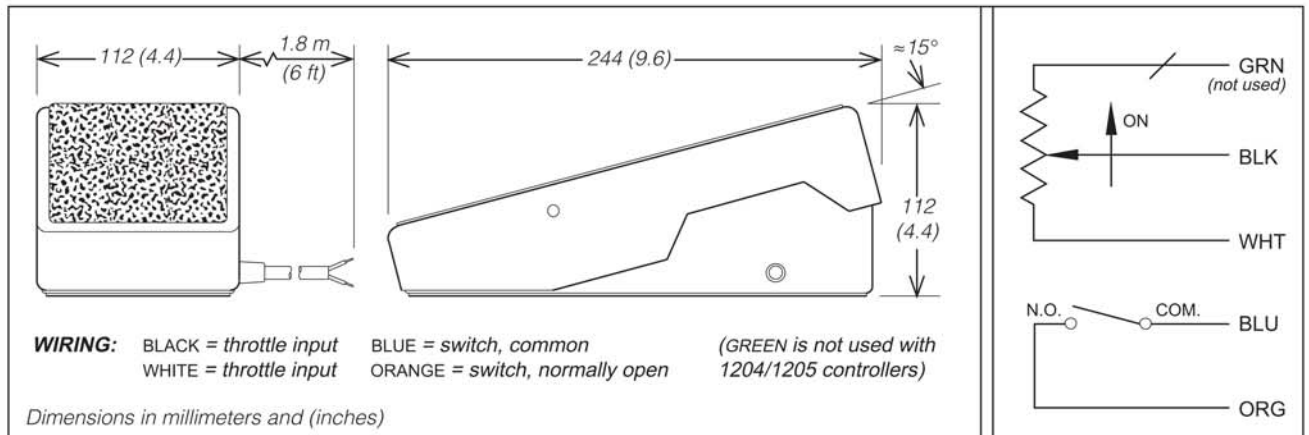
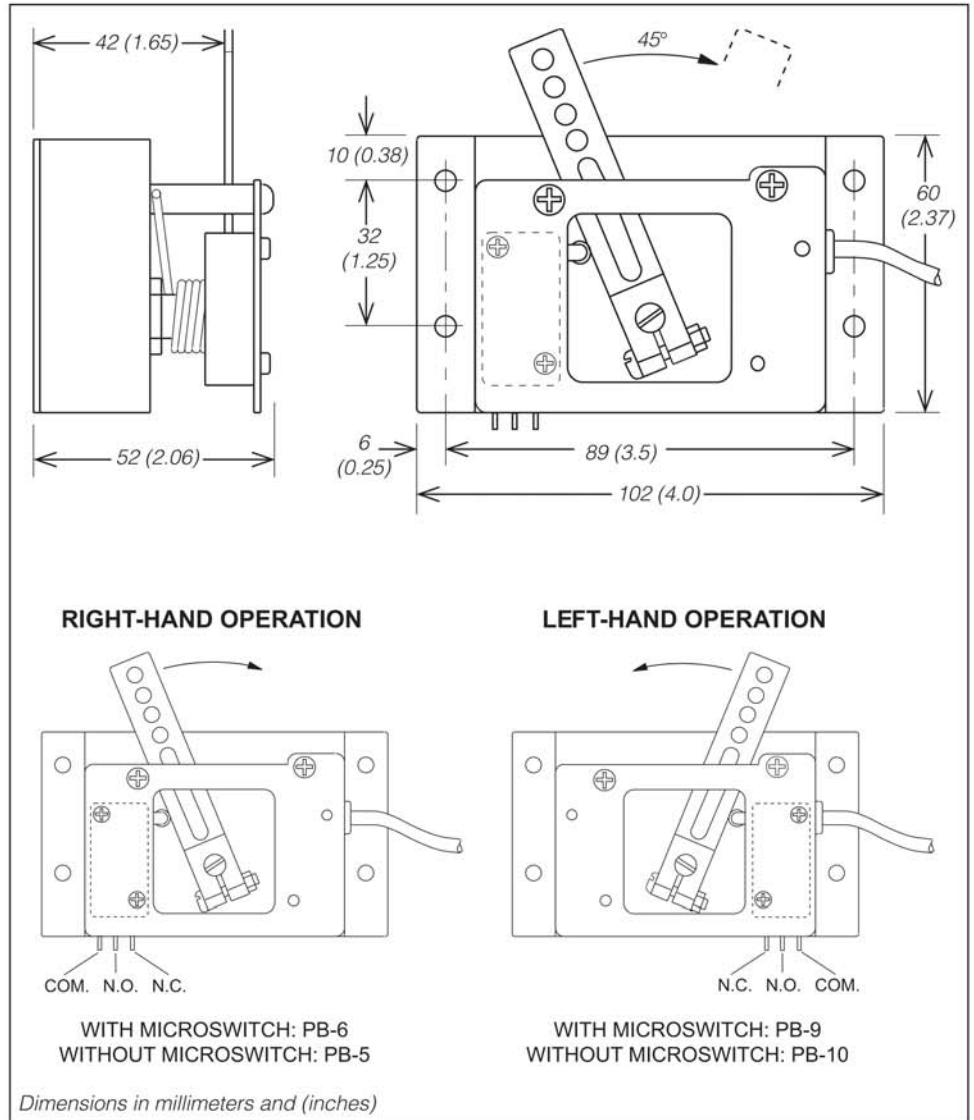

**Fig. 4** Curtis PMC footpedal FP-2.

### OTHER HARDWARE

The recommended hardware for a typical 1204/1205 controller installation is shown in Figure 5.

Contactors should be mounted in a clean, dry location. If such a location is unavailable, a cover should be used to deflect dirt and water splash.

The precharge resistor connected to the main contactor, and the coil suppression diodes connected to the main contactor and to the forward/reverse contactors, are somewhat delicate components. Care should be taken to prevent damage to them during installation.

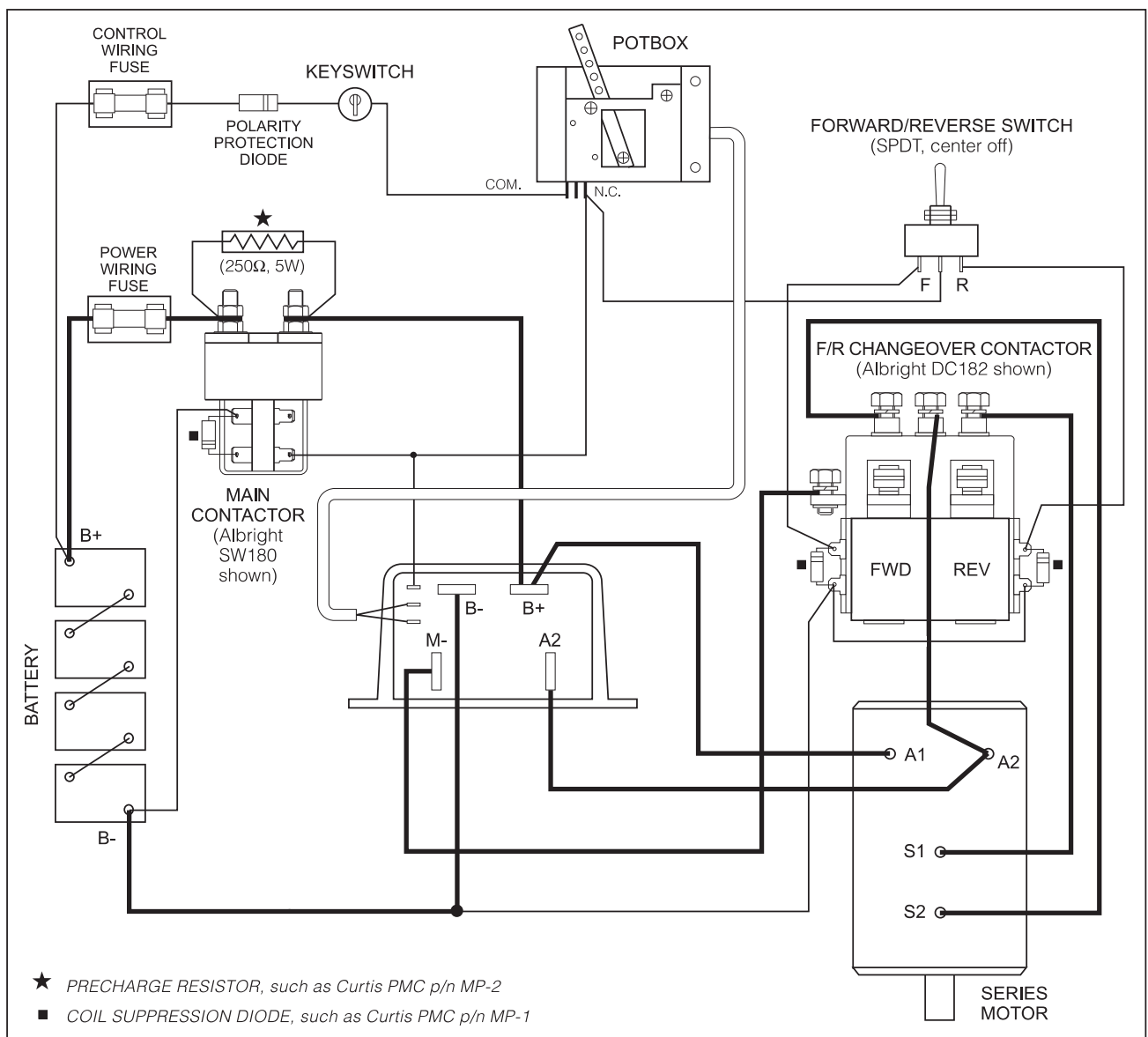

**Fig. 5** Typical installation,  
 Curtis PMC 1204/1205 controller.

### Main Contactor

Most applications use a main contactor in series with the battery positive (B+) cable to disconnect all power when the system is turned off, as shown in Figure 5. A heavy-duty single-pole, single-throw (SPST) contactor with silver-alloy contacts is recommended, such as an Albright SW80 or SW180 (*available from Curtis*).

A coil suppression diode, such as a Curtis PMC p/n MP-1 (which is rated at 100 volts, 3 amps), should be used on the contactor coil.

The rapid charging of the controller's internal filter capacitors causes a high inrush current to flow briefly when the contactor closes. To extend contact life, a precharge resistor, such as Curtis PMC's p/n MP-2, is recommended; the resistor precharges the capacitors and reduces the inrush current through the contacts. If an inexpensive "can" type solenoid is used, the resistor is mandatory to prevent contact welding.

### Forward/Reverse Contactors

The forward/reverse contactor coils must match the vehicle's battery voltage. Use of two single-pole, double-throw (2×SPDT) contactors is recommended. Although inexpensive "can" type solenoids can be used, their ratings are typically not sufficient for long life. Changeover contactor sets — such as the Albright DC88 and DC182 (*available from Curtis*) — are therefore recommended.

A coil suppression diode, such as a Curtis PMC p/n MP-1 (which is rated at 100 volts, 3 amps) should be used on each of the forward/reverse contactor coils.

### Forward/Reverse Switches

The forward/reverse contactor coils can be operated by any type of single-pole, double-throw (SPDT) center-off switch capable of switching the coil current. Toggle or rocker switches are generally used.

If your controller has the optional high pedal disable (HPD) feature and you plan to wire it for freewheeling, the best switch to use is a double-pole, double-throw (DPDT) "hesitation switch"— a toggle switch with a mechanism that forces it to stop in the center (neutral) position before going into the opposite direction. If a standard switch is moved quickly from one direction to the other, it may not be in neutral long enough to actuate HPD, and the motor will plug brake instead of freewheeling. The switch must be in neutral for several milliseconds to actuate HPD.

### Keyswitch

The vehicle should have a master on/off switch to turn the system off when not in use. A keyswitch is typically used for this purpose.

### Polarity Protection Diode

For polarity protection, a diode should be added to the control circuit. This diode must be sized appropriately for the maximum total contactor coil currents.

### Control Wiring Fuse

To protect the control circuitry from accidental shorts, a small fuse (typically 10 amps) connected in series with the B+ feed to the control circuitry wiring is recommended.

### Power Wiring Fuse

To protect the power wiring circuit, a fuse appropriate for the controller's rated current (*see Appendix C*) is recommended.

## 3

## WIRING

**CONNECTIONS: Low Current**

Three 1/4" push-on terminals are provided for the low current connections to the KSI and throttle inputs.

For the control wiring, 0.75 mm<sup>2</sup> (#18 AWG) vinyl insulated stranded wire is recommended.

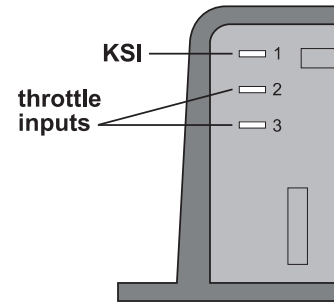
**CONNECTIONS: High Current**

Four tin-plated solid copper bus bars are provided for the high current connections to the battery and motor:

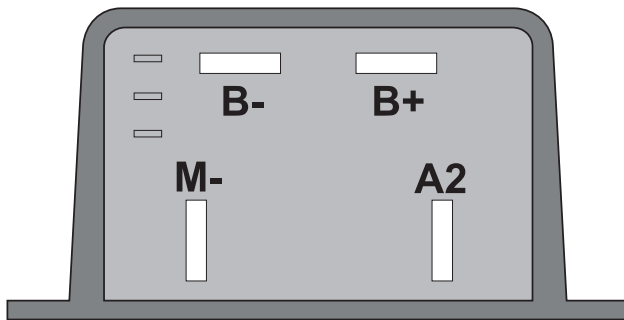

- M-** output to motor field
- B-** negative connection to battery
- B+** positive connection to battery and to motor armature
- A2** plug diode to motor armature

The cables used for the battery and motor connections must be heavy enough to carry the high current required. A minimum size of 25 mm<sup>2</sup> (#4 AWG) is recommended. Rubber insulated welding cable is convenient to work with because of its flexibility.

Connections to the controller bus bars should be made with lugs suitable for the cable used, fastened by M8 (5/16") bolts and nuts. **When tightening the bolts, two opposing wrenches should be used.** Failure to use the double-wrench technique could cause undue strain to be placed on the internal connections, and could also result in cracked seals around the bus bars.





turn off the main contactor and the forward/reverse contactors. This will act as a safety feature by removing power from the motor control system when the keyswitch is turned off.

Interlocks (seat switches, battery charger interlocks, etc.) should be wired in series so that they turn off the controller KSI and the contactors.

### Forward/Reverse Wiring (with standard power wiring)

These forward/reverse wiring schemes assume the standard power wiring (shown by the heavy lines in Figure 6). Some vehicles, especially those previously using older, resistor-type controllers, may reverse the motor armature rather than the field winding. Be careful if you are replacing this type of controller. **When using the Curtis PMC controller it is essential that the field be reversed and that the armature be connected directly to the controller's B+ and A2 terminals, because the plug diode inside is connected to these terminals.**

#### *Plug braking*

The standard forward/reverse control wiring (shown by the light lines in Figure 6) provides plug braking. The forward/reverse switch should be in the positive feed to the contactor coils, so that they can be turned off by the keyswitch, interlocks, and pedal microswitch. The coil of one contactor or the other is energized to select the direction desired.

#### *Freewheeling (wiring to inhibit plug braking)*

If your controller has the HPD option, this feature can be used to inhibit plug braking by briefly turning off the controller's KSI when the forward/reverse switch goes through neutral. As shown in Figure 7, another set of

**Fig. 7** *Control wiring for inhibiting plug braking, in order to allow freewheeling.*

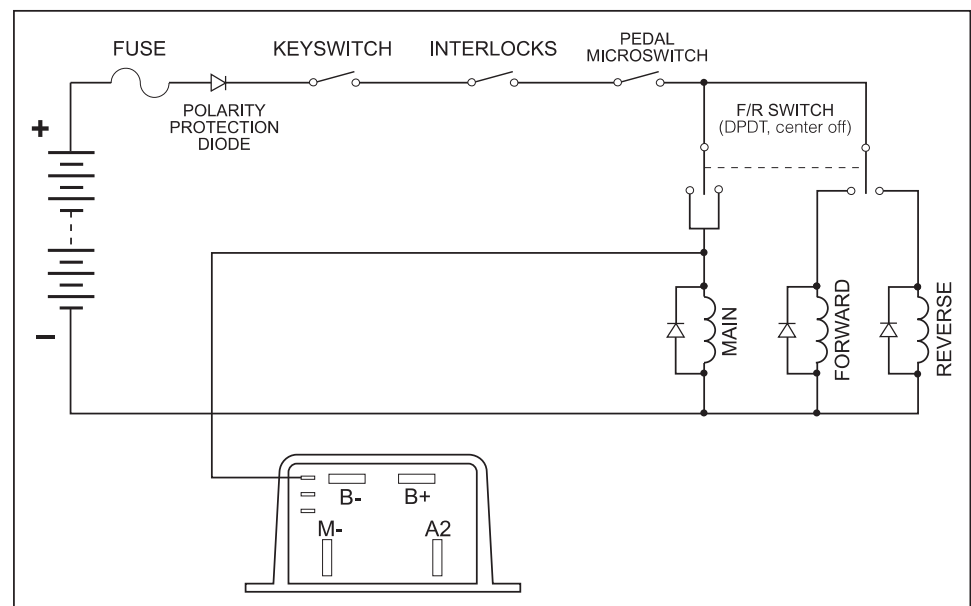

contacts is added on the forward/reverse switch. Therefore, a double-pole, double-throw (DPDT) center-off switch must be used for this setup. A “hesitation switch” is recommended, to ensure the switch is in neutral long enough to actuate HPD and inhibit plug braking.

Plug braking can be reactivated during freewheeling by releasing the throttle and reapplying it.

### Forward/Reverse Wiring (with alternate power wiring)

The basic wiring scheme in Figure 6 shows reversing via two single-pole, double-throw (2×SPDT) contactors. Your vehicle may be configured for a different type of reversing. Two alternative power wiring schemes are described below—reversing with four single-pole, single-throw (4×SPST) contactors, and reversing mechanically rather than electrically.

#### Power wiring for reversing with 4×SPST contactors

It is possible to use four single-pole, single-throw (4×SPST) contactors, wired as shown in Figure 8. However, this configuration has the disadvantage that if any one of the contactors sticks closed, the motor field is effectively shorted out in one drive direction. The motor will not turn, and it may be damaged if operated like this for long.

Other disadvantages are that four, rather than two, contactors must be mounted and wired, and that the coils draw twice as much power. The control wiring options for the 4×SPST contactors are the same as for the 2×SPDT contactors (see Figures 6 and 7).

As previously noted in the section on standard power wiring, **when using the Curtis PMC controller it is essential that the field be reversed and that the armature be connected directly to the controller’s B+ and A2 terminals, because the plug diode inside is connected to these terminals.**

**Fig. 8** Power wiring for reversing with 4×SPST contactors.

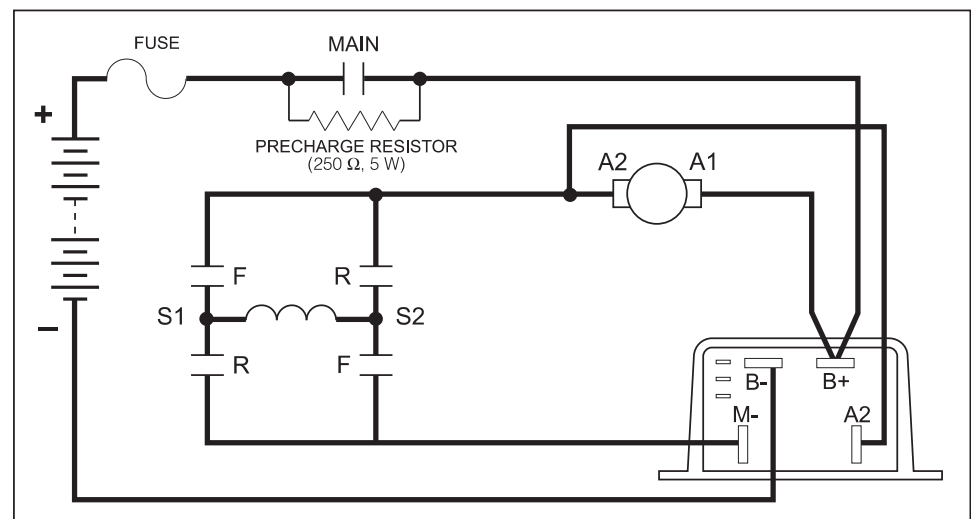

*Power wiring for mechanical reversing switch (golf car type)*

As shown in Figure 9, this type of switch mechanically interchanges the two motor field cables by rotating a movable contact bar. The configuration shown is typical; many variations are in use.

**Fig. 9** *Power wiring for reversing with mechanical forward/reverse switch arm.*

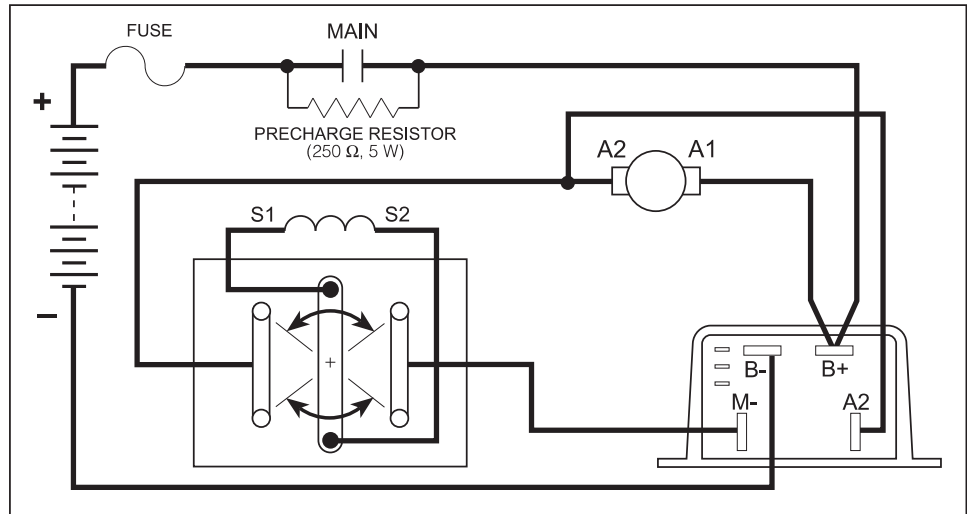

## Throttle Pot Wiring

### Standard potbox wiring

If the throttle input to the controller is from a Curtis PMC potbox or footpedal, the wiring is simple: just connect the two wires of the potbox/footpedal cable to the two push-on terminals of the controller, as shown in Figure 6. It doesn't matter which wire goes on which terminal. The wires can be extended as required.

Any suitable potentiometer of 5 k $\Omega$  nominal resistance will work with the standard throttle input of the 1204/1205 controllers. As shown in Figure 10, connection should be made to the wiper and to one outer terminal of the pot so that resistance increases as the accelerator is applied.

**Fig. 10** *Standard throttle pot, 0–5k $\Omega$ .*

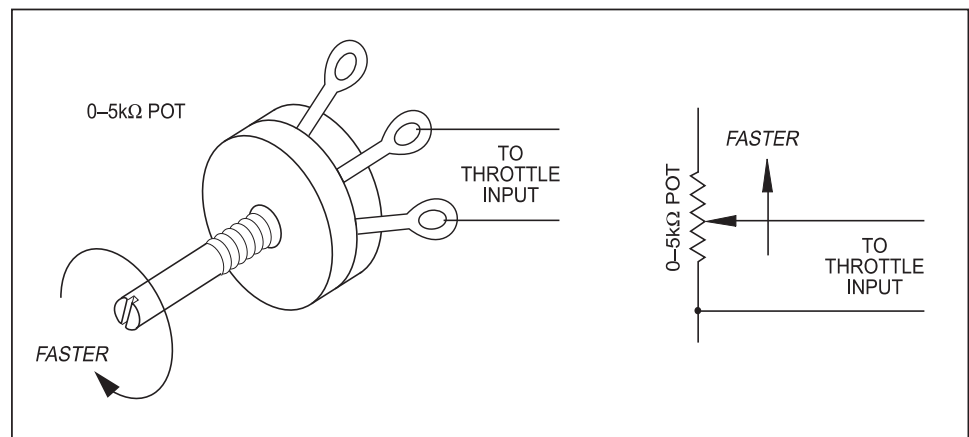

### Pots for twist-grip throttles

Twist grip throttles either twist in only one direction (and are used only for acceleration), or they twist both ways (and are also used for reversing, by means of microswitches that select a direction contactor). For twist grips that twist in only one direction, the controller throttle input can be from a 5 k $\Omega$  pot as shown above in Figure 10.

For twist grips that twist both ways, a pot capable of going from zero in neutral to 5 k $\Omega$  in each direction can be used. A mechanism can be designed to make a standard pot turn in the same direction regardless of which direction the twist grip is turned. Alternately, a 4-terminal, center-tapped 10 k $\Omega$  pot can be coupled directly to the twist grip, as shown in Figure 11.

**Fig. 11** *Bi-directional twist-grip throttle with 10 k $\Omega$  center-tapped, 4-terminal pot.*

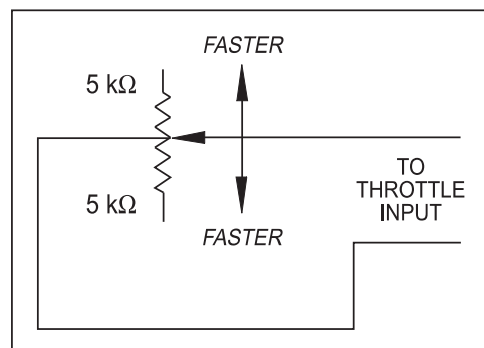

A third method of accommodating bi-directional twist grip throttles uses a standard potentiometer and a controller with a

**Fig. 12** *Bi-directional twist-grip throttle with a standard 20 kΩ pot and a controller with the optional 5kΩ–0 throttle input.*

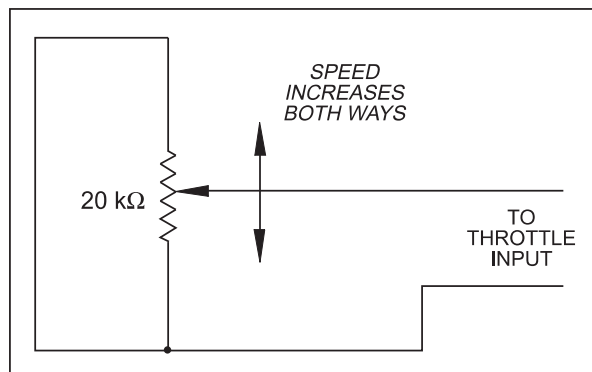

nonstandard throttle input. As shown in Figure 12, a standard 20 kΩ pot is used, with its end terminals wired together. The resistance goes from 5 kΩ at neutral to zero at the extremes — the opposite of the standard throttle input configuration. Contact the factory if you need this type of controller.

**WARNING:** *with the input circuit shown in Figure 12, potentiometer or wiring open circuits turn off the controller's output. However, pot wiring shorts appear the same as a normal zero ohm signal to the controller, and will produce full speed operation if the short occurs while the power is on.*

#### Reduced speed operation

Vehicle top speed can be easily limited, for safety or other reasons. A single resistor connected in parallel with the throttle pot will reduce maximum speed according to its resistance value, as shown in Figure 13. Use of a variable resistor makes adjustment of maximum speed easier. With a switch, speed can be limited in reverse only, or the speed reduction can be switched off — for example, to allow authorized personnel to run the vehicle outdoors at full speed.

The speed reduction shown in the curve is approximate. The actual vehicle top speed will depend on the motor characteristics and the vehicle

**Fig. 13** *Reduced speed operation (with standard 0–5kΩ pot).*

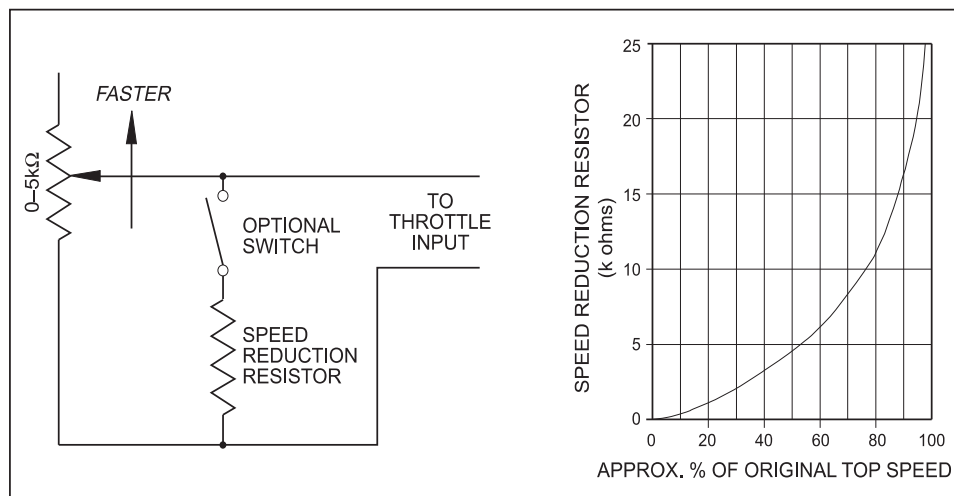

load. You should determine by experiment the proper resistor value to give the desired speed reduction. (NOTE: with reduced speed operation, only top speed is reduced; full power is maintained for starting at low speeds.)

Unlike resistor controllers, Curtis PMC 1204/1205 controllers operate efficiently in the reduced speed mode, because little power is lost through the controller.

**Electronic Throttle Wiring**

Curtis PMC’s electronic throttle, ET-XXX, is wired as shown in Figure 14. It requires a controller with the optional 0–5V throttle input.

**Fig. 14** *Curtis electronic throttle (ET series) with a controller having the optional 0–5V throttle input.*

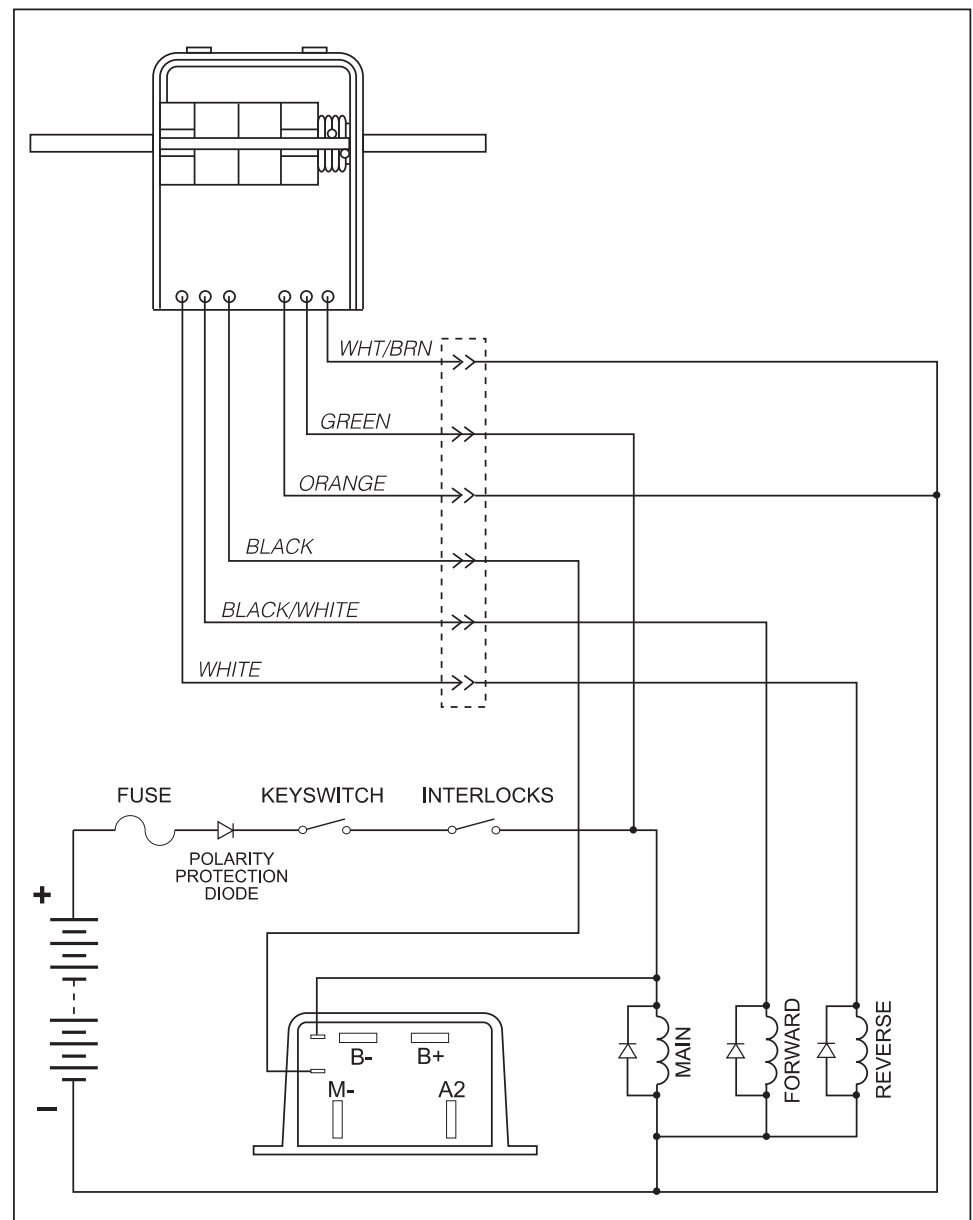

## WIRING: PM MOTORS

Wiring for controllers in vehicles with permanent magnet motors is the same as in those with series motors, except for the forward/reverse circuit. PM motors have only two terminals: the armature brushes. The magnetic field is provided by the permanent magnets and cannot be reversed; instead, the motor is reversed by interchanging the armature leads.

The PM motor must be connected, via the forward/reverse circuitry, to the controller's B+ and M- bus bars. If your controller is designed for use with either series or PM motors, it will have an A2 bus bar which you should leave unconnected. If your controller is designed for use only with PM motors, it will have no A2 bus bar.

Basic PM motor wiring — using two single-pole, double-throw (2×SPDT) contactors — is shown in Figure 15. Note that when the forward/reverse switch is in the neutral position, neither of the direction contactors is operated and the motor is shorted. This will produce sudden braking if neutral is selected while the vehicle is moving, or if the motor is reversed while the vehicle is moving. The motor acts as a generator, and will effectively be shorted out by the freewheel diode inside the controller. The faster the vehicle is moving when the motor is shorted out, the more

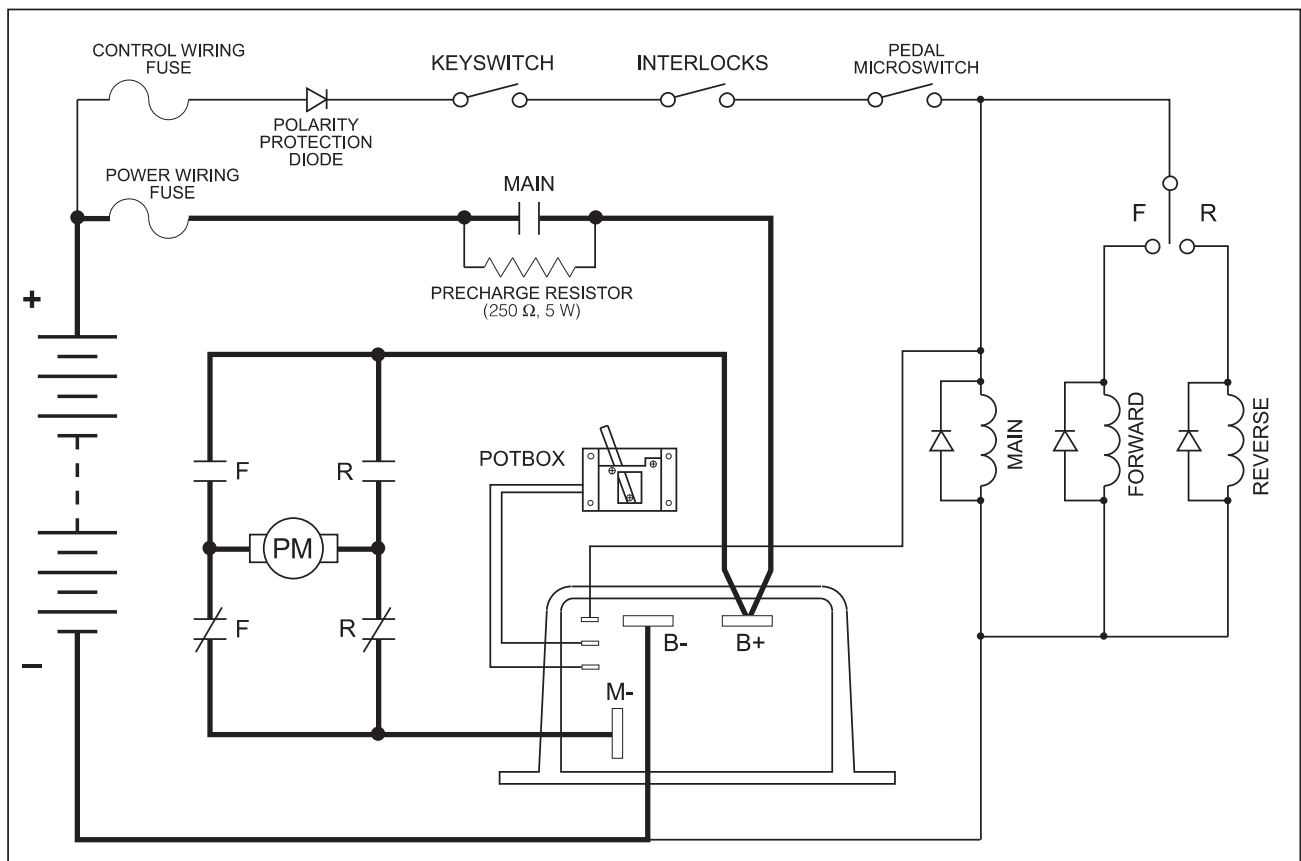
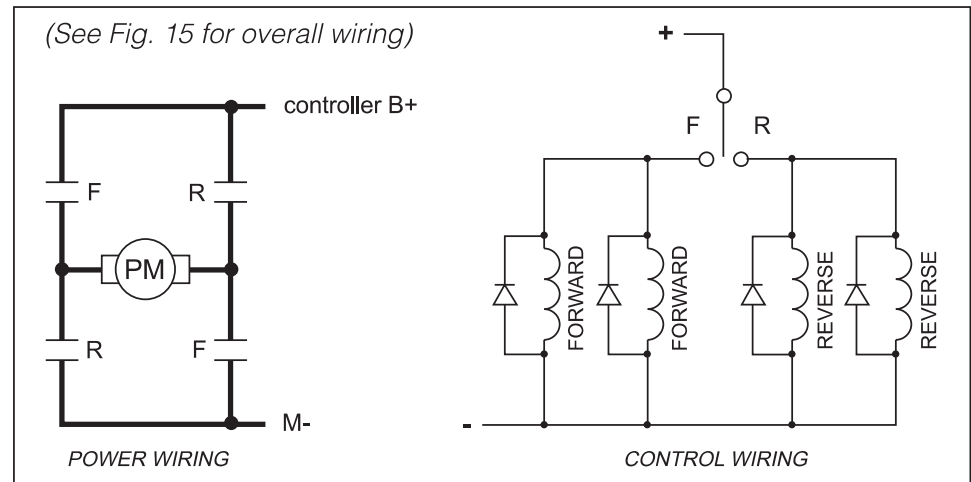

**Fig. 15** Basic wiring for use with PM motors.

violent the effect of the sudden braking will be. If violent braking is not acceptable for your application, use one of the wiring schemes described below to allow the motor to freewheel in neutral or whenever the pedal is released. However, note that **sudden braking will still occur if the opposite direction is selected and the pedal is re-applied while the vehicle is still moving.**

A partial solution is to arrange four single-pole, single-throw (4×SPST) contactors to open the motor circuit whenever the pedal is released. This arrangement, shown in Figure 16, causes the vehicle to freewheel in neutral or whenever the pedal is released. The drawback to this scheme is that if one of the contactors sticks closed, the controller’s output is shorted and the controller may be damaged. For this reason, we do not recommend the 4×SPST arrangement — although it is widely used.

**Fig. 16** PM motor wiring to provide freewheeling, using 4×SPST contactors. Although this configuration is widely used, we do **not** recommend it.



A better approach — and the one we recommend — is shown in Figure 17. The motor is reversed by the two single-pole, double-throw (2×SPDT) contactors. A third contactor (SPST) opens the motor circuit in neutral or when the pedal is released, allowing the motor to freewheel.

**Fig. 17** Preferred PM motor wiring to allow freewheeling, using 2×SPDT direction contactors with a third contactor (SPST). A resistor can be added across the third contactor to provide dynamic braking instead of freewheeling.

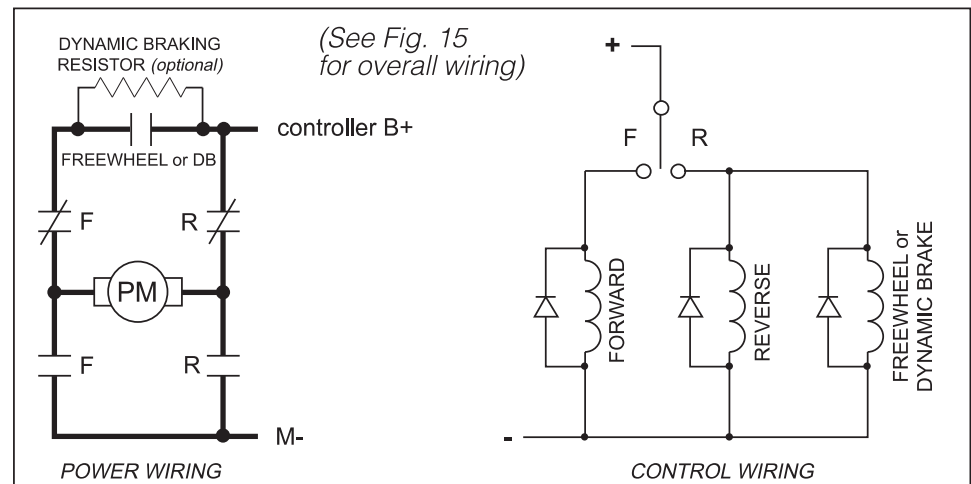



---

If you prefer dynamic braking to freewheeling, you can install a dynamic braking resistor. The motor generates power in slowing down the vehicle; the dynamic braking resistor dissipates this power as heat. The amount of braking torque is determined by the resistance, and is proportional to the vehicle's speed. The resistor gets hot and must be sized and mounted accordingly. (NOTE: The size of the motor and the amount of braking desired are factors in determining the appropriate dynamic braking resistor; contact Curtis for guidelines.) The N.O. and N.C. contacts of the forward/reverse contactors must be wired as shown in Figure 17 or this scheme will not work.

Note that in all the PM motor wiring schemes shown (i.e., Figures 15–17), the forward/reverse switch is double-pole, double-throw (DPDT) center-off. In addition to operating the forward/reverse contactors, the switch turns on the controller's KSI and main contactor when forward or reverse is selected. By turning off the KSI in the neutral position, the controller's HPD feature will inhibit the controller output if the forward/reverse switch is changed with the pedal depressed. While this will not prevent the braking effect of reversing direction with the vehicle moving, it will at least keep the motor from being driven in the opposite direction.

A forward/reverse interlock module (Curtis PMC p/n 1301) is available for 24–36V models to prevent reversing direction while the vehicle is in motion. This module allows the contactors to be reversed only when the motor's back EMF has come down to a preset level. Contact Curtis for Application Notes providing further information.

## INSTALLATION CHECKOUT

Carefully complete the following checkout procedure before operating the vehicle. If a step does not test correctly, use the troubleshooting guide (Section 5) to identify the problem.



*Put the vehicle up on blocks to get the drive wheels off the ground before beginning these tests.*

*Don't let anyone stand in front of or behind the vehicle during the checkout.*

*Make sure the keyswitch is off and the vehicle is in neutral before beginning.*

*Wear safety glasses and use well-insulated tools.*

- A. Connect the battery. Use a voltmeter to verify that the proper voltage and polarity appears at the battery B+ and B- terminals.
- B. Check the voltage at the controller B+ and B- bus bars. If your system has a precharge resistor in parallel with the main contactor, you should see approximately 90% of the full battery voltage. If your system does not have a resistor, temporarily connect one (100 to 200 ohms, 5 watts, or a 100 watt light bulb). The voltage at the controller should rise to approximately 90% of the full battery voltage.
- C. If "A" and "B" do not check out, troubleshoot the wiring connections. Do not turn on the keyswitch until the trouble is corrected and "A" and "B" check out.
- D. With the forward/reverse switch in neutral, turn on the keyswitch. If the motor runs without the throttle being applied, turn the keyswitch off and recheck the wiring. If the motor does **not** run without the throttle applied, proceed with the checkout. Select a direction and slowly apply the throttle; the motor should now respond.
- E. Look to see which direction the wheels are turning. If the wheels are going the wrong way, turn everything off and interchange the motor field connections.
- F. If you have HPD, check it next. Turn off the keyswitch and direction switch. Apply the throttle, turn the keyswitch on, and then select a

direction. The motor should not run. Release the throttle and re-apply it — the motor should now run. If the motor runs before you release the throttle, recheck the wiring.

G. Take the vehicle down off the blocks and drive it in a clear area. It should have smooth acceleration and good top speed.

H. On vehicles that are intended to plug brake, test the plug braking by driving forward at moderate speed and shifting into reverse without letting up on the throttle. The vehicle should smoothly brake to a stop and accelerate in reverse.

I. On vehicles that are intended to have plug braking inhibited, verify that the maneuver in “H” produces freewheel coasting.

## 4

## MAINTENANCE &amp; ADJUSTMENT

Curtis 1204/1205 controllers and potboxes require only minimal maintenance if properly installed. **NOTE:** The controllers are sealed and thus are not field serviceable.

## CONTROLLER

Maintenance

It is recommended that the following two steps be performed occasionally. **First remove power by disconnecting the battery, and discharge the capacitors in the controller** (with a light bulb or a 2–10  $\Omega$ , 25 W resistor connected for a few seconds across B+, B-). Follow good safety practices: get the vehicle drive wheels off the ground, wear safety glasses, and use insulated tools (*see page 2*).

1. Make sure the electrical connections to the controller (and to the motor, contactors, etc.) are tight. When checking the controller bus bar connections for tightness, use two opposing wrenches. This double-wrench technique will help avoid putting stress on the bus bars, which could crack the seals. **Always use insulated wrenches.**
2. Inspect all seals at the front and back of the controller. If necessary, use a moist rag to wipe these areas clean enough so that you can see the seals. Look for cracks and other signs of seal damage.

If the seals are intact, clean the controller thoroughly either by washing it off or by wiping it clean with a moist rag. **Power must not be reapplied until the controller terminal area is completely dry.**

If the seals have been damaged, there are several possible causes. Perhaps the double-wrench technique was not used when the cables were installed. Perhaps the vehicle's environment requires that the controller be better protected: either by mounting it in a different location, or by installing a protective cover.

**Damaged seals can lead to faulty operation.** We strongly recommend replacing controllers that have faulty seals.

### Adjustment

On some models, the plug braking current and acceleration rate settings are adjustable. On these adjustable controllers, the adjustment pots are located as shown in Figure 18.

**Fig. 18** *Adjustment pots.*

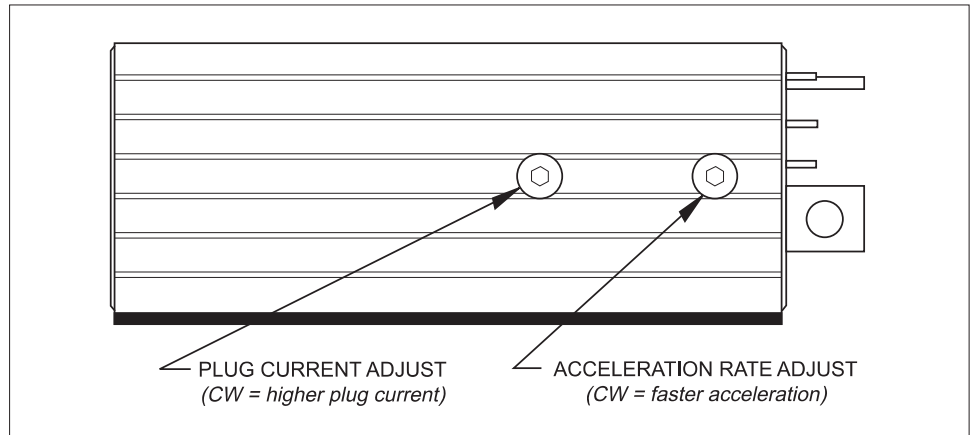

Use the following adjustment procedure. **The keyswitch should be off during adjustment.**

1. Remove the socket head screw (1/8" Allen) for the adjustment you want to make.
2. Adjust the internal potentiometer using a small **insulated** screwdriver (*available from Curtis*).
3. Replace the socket head screw and nylon seal washer. To prevent stripping, do not over-tighten.

## POTBOX

### Maintenance

Potbox maintenance is similar to controller maintenance: inspect for integrity of connections and mounting, and clean (with a moist rag) as required.

### Adjustment

Curtis PMC potboxes are factory set and rarely require user attention. To test and adjust, connect an ohmmeter to the potbox wires and use this procedure:

1. With the spring holding the lever arm against the return stop, the resistance should be less than 50 ohms. Slowly move the lever. If the resistance abruptly starts to increase when the lever is 3 mm (1/8") from the stop (1.5 mm [1/16"] for potboxes without the microswitch), no adjustment is needed.
2. If adjustment is required, loosen the screw holding the lever on the pot shaft. Use a screwdriver to rotate the pot shaft slightly with respect to the lever. Recheck the point at which the resistance starts to increase and continue making adjustments until the increase occurs at 3 mm (1/8") [at 1.5 mm (1/16") for potboxes without the microswitch]. When adjustment is correct, tighten the screw holding the lever on the pot shaft, then recheck to see that this action did not disturb the adjustment. Make sure that the lever is still seated down on the pot shaft below the slight bevel on the end of the shaft.
3. Check the resistance with the lever pushed all the way to the other stop. It should be between 4500 and 5500 ohms. If it is outside this range, the potbox is faulty and should be replaced.
4. For potboxes equipped with a microswitch, check for correct switch operation. Use an ohmmeter, or simply listen for the slight click the switch makes. It should operate when the lever is 1.5 mm (1/16") from the return stop. If it does not, adjust by loosening the two screws holding the slotted microswitch mounting plate to the stop spacers and moving the plate. Recheck the switch operating point after tightening the screws.

# 5

## TROUBLESHOOTING AND BENCH TESTING

*Some behaviors that may seem to suggest controller malfunction do not, in fact, indicate a problem but rather are typical of normal operation. Before undertaking the diagnostic tests, check to see whether your problem is addressed in the first section, “Operational Notes.” The diagnostic tests are designed to enable you to determine whether the trouble is in the controller or in some other part of the motor control circuitry. **The controllers themselves are sealed and not field serviceable; contact your local Curtis PMC service center if the problem is in the controller.** The diagnostic section provides enough detail to enable you to track circuitry problems to their source and repair them. Finally, the bench tests will allow you to confirm controller operation in a simple, low-power test configuration. Bench testing is primarily intended for checking out a number of controllers on a regular basis.*

### OPERATIONAL NOTES

#### Noise

Controller operation is normally silent. An exception is that a 1 kHz tone may be heard during plug braking. This noise is normal and indicates that plugging is taking place. The noise will stop when plug braking stops.

#### Inability of Vehicle to Plug Brake to a Stop on a Steep Ramp

If the vehicle is rolling backwards down a steep ramp in reverse and the throttle is applied demanding forward drive, the controller will attempt to plug the vehicle to a stop. If the ramp is so steep that the plugging current setpoint is insufficient to stop the vehicle, it will continue to be braked but will nevertheless roll down the ramp. If the mechanical brakes are applied, and the vehicle is stopped, the full drive current will be available when the throttle is applied and the vehicle will proceed up the ramp.

#### Sluggish Vehicle Behavior

Loss of power will be noticeable when the batteries become overly discharged. This is a normal response to low battery voltage. Curtis PMC 1204/1205 controllers are designed to protect against damage caused by low batteries. On 24–36 volt controllers, for example, power to the motor is cut back when the voltage goes below 16 volts. Refer to the specifications (Appendix C) for other models.

### Hot Controller

If the controller gets hot, it does not necessarily indicate a serious problem. Curtis PMC 1204/1205 controllers protect themselves by reducing power to the motor if their internal temperature exceeds 75°C (167°F). Power output will be reduced for as long as the overheat condition remains, and full power will return when the unit cools.

In typical applications, overheating will rarely be a problem. However, operation with oversized motors and vehicle overloading may cause overheating, particularly if the controller is mounted so that heat cannot be conducted away from its case or if other heat-generating devices are nearby. If thermal cutback occurs often during normal operation, the controller is probably undersized and should be replaced with a higher current model.

### Unintended Activation of HPD

Sudden applications of full throttle may activate the HPD feature, in applications where the pedal microswitch is wired in line with KSI. This happens if the pot is rotated well into its active stroke before the microswitch can cause the controller to power up. Normal nonabusive application of the throttle should not cause this action.

## **IN-VEHICLE DIAGNOSTIC TESTS**

These tests require a general purpose volt ohmmeter; you can use either a conventional “V-O-M” or an inexpensive digital voltmeter.

The troubleshooting chart (*opposite*) serves as a guide to the procedures that follow. Before starting these tests, refer to the appropriate wiring diagrams and make sure your controller is hooked up properly.

**CAUTION**



**Working on electric vehicles is potentially dangerous.** You should protect yourself while performing the diagnostic tests by jacking up the vehicle to get the drive wheels off the ground, opening the battery circuit before working on the motor control circuit, wearing safety glasses, and using properly insulated tools (*see page 2*).



**Fig. 19** Guide to troubleshooting procedures. [To use this guide, refer to the specified **PROCEDURES** .]

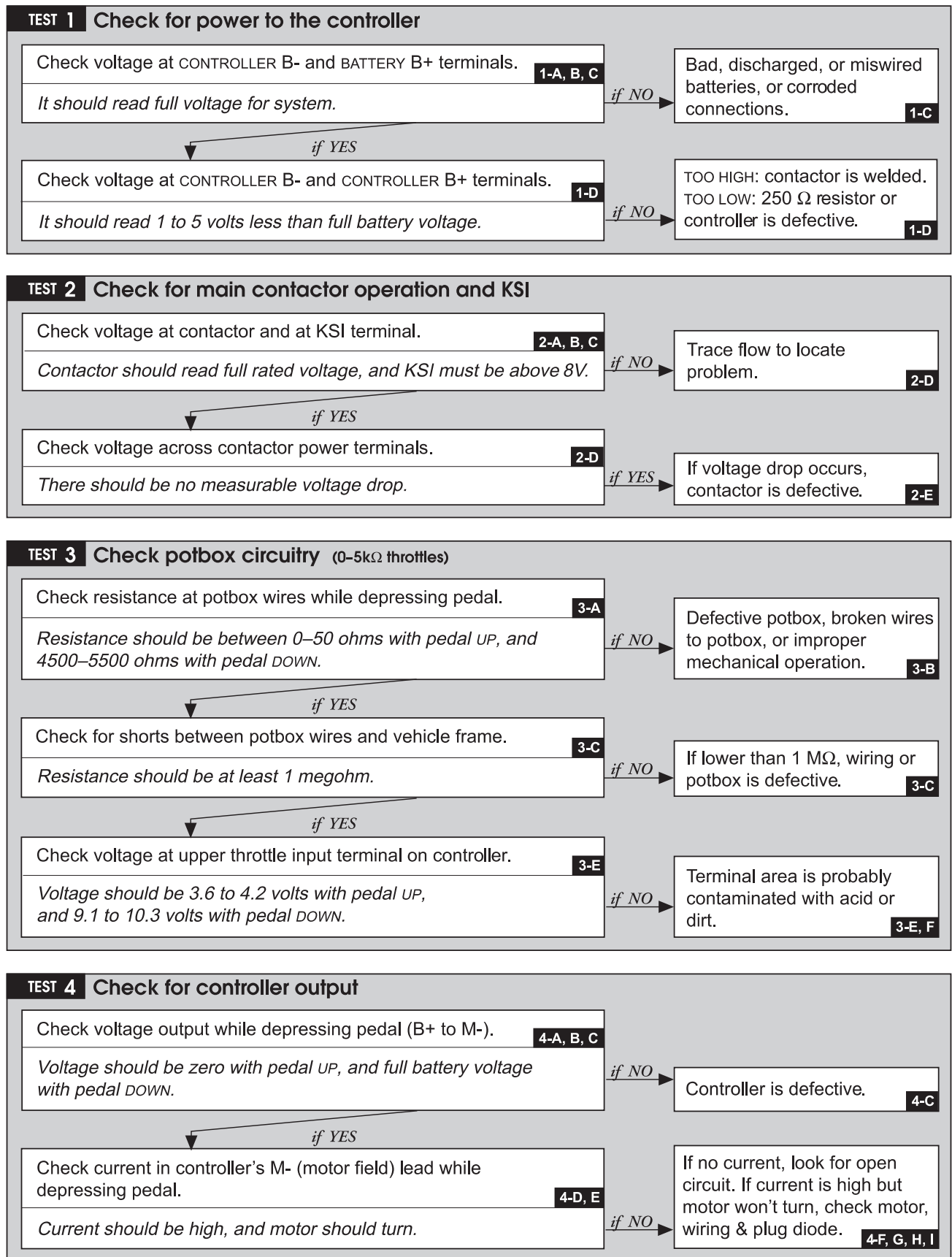

**TEST 1 Check for power to the controller**

- 1-A** Leave the keyswitch off for these tests.
- 1-B** Verify that battery (-) connects to the B- terminal of the controller. Connect voltmeter (-) lead to this point.
- 1-C** Connect voltmeter (+) to the battery side of the main contactor. Check for full battery voltage. If it is not there, the trouble is in the battery pack, the cables to it, or the power fuse.
- 1-D** Connect the voltmeter (+) lead to the controller B+ terminal. You should read a voltage 1 to 5 volts less than the full battery voltage. If this voltage is zero or close to zero, the trouble is either a bad controller, a bad 250  $\Omega$  resistor across the contactor, or an incorrectly connected cable between the contactor and the controller. Trace the cable to make sure it is hooked up right. Remove and test the 250  $\Omega$  resistor with an ohmmeter. If these check out, the controller is malfunctioning. If you see full battery voltage at this point, then the contactor has welded and must be replaced.

**TEST 2 Check for main contactor operation and KSI**

- 2-A** Turn the key on, place the forward/reverse switch in forward or reverse, and depress the footpedal until its microswitch operates. (In these procedures, we assume the footpedal is equipped with the recommended microswitch.)
- 2-B** This should cause the main contactor to operate with an audible click. Connect the voltmeter across the contactor coil terminals. You should see full battery voltage (minus the polarity diode drop).
- 2-C** The controller KSI terminal should also be getting full battery voltage. Verify this by connecting the voltmeter (-) to the controller's B- terminal, and the voltmeter (+) to the controller's KSI terminal.
- 2-D** If the contactor and KSI terminal are not getting voltage, that's the problem. Use the voltmeter to find out where it is not getting through. Connect the voltmeter (-) to the controller's B- terminal and check the following points with the voltmeter (+) lead to trace

- the flow:
1. First, check both sides of the control wiring fuse.
  2. Check both sides of the polarity protection diode to make sure its polarity is correct.
  3. Check both sides of the keyswitch.
  3. Check both sides of the pedal microswitch.
  4. Finally, check the contactor coil and controller KSI.

**2-E** If the contactor coil and KSI are getting voltage, make sure the contactor is really working by connecting the voltmeter across its contacts (the big terminals). There should be no measurable voltage drop. If you see a drop, the contactor is defective. (We assume the recommended precharge resistor is in place.)

### **TEST 3** Check the potbox circuitry

The following procedure applies to the standard throttle input configuration for these controllers, which is a nominal  $5\text{k}\Omega$  pot connected as a two-wire rheostat ( $0 = \text{full off}$ ,  $5\text{ k}\Omega = \text{full on}$ ), and also to  $5\text{k}\Omega-0$  configurations. Some 1204/1205 controllers are sold with other input characteristics. If your installation uses a controller with a throttle input other than  $0-5\text{k}\Omega$  or  $5\text{k}\Omega-0$ , find out what its range is and use a procedure comparable to the one below to make sure your pedal/potbox is working correctly.

**3-A** With the keyswitch off, pull off the connectors going to the throttle input of the controller. Connect an ohmmeter to the two wires going to the potbox and measure the resistance as you move the pedal up and down. The resistance at the limits should be within these ranges:

	RESISTANCE (in ohms)	
	STANDARD	
	$0-5\text{k}\Omega$ POT	$5\text{k}\Omega-0$ POT
Pedal up:	0 – 50	4500 – 5500
Pedal down:	4500 – 5500	0 – 50

**3-B** If these resistances are wrong, it is because the pot itself is faulty, the wires to the pot are broken, or the pedal and its linkage are not moving the potbox lever through its proper travel. Actuate the pedal and verify that the potbox lever moves from contacting the pedal-up

stop to nearly contacting the pedal-down stop. If the mechanical operation looks okay, replace the potbox.

- 3-C** While you have the potbox wires off the controller, use an ohmmeter to check for shorts between these wires and the vehicle frame. You should see a resistance of at least 1 megohm. If it is lower than that, inspect the wiring for damaged insulation or contact with acid. If necessary, replace the potbox.
- 3-D** Push the wires back on the controller terminals. It doesn't matter which wire goes on which terminal.
- 3-E** Inspect the terminal area of the controller closely. Occasionally a buildup of dirt or acid residue of a conductive nature causes electrical leakage between the throttle input terminals and the B- or M-terminals, leading to faulty controller operation. To check for this problem, measure the voltage at the appropriate throttle input terminal (upper for 0–5k $\Omega$  pots, lower for 5k $\Omega$ –0 pots), by connecting the voltmeter (-) lead to the controller's B- terminal. The keyswitch must be on and a direction selected for this test.

	ACCELERATOR INPUT VOLTAGE (in volts)	
	STANDARD	
	0–5k $\Omega$ POT <i>UPPER TERMINAL</i>	5k $\Omega$ –0 POT <i>LOWER TERMINAL</i>
Pedal up:	3.8	4.3
Pedal down:	9.5	10.2

Compare your readings with these; if they are different by more than a few tenths of a volt, contamination is probably the cause.

- 3-F** Carefully clean off the terminal area of the controller with a cotton swab or clean rag moistened with water, and dry thoroughly.



**Be sure to turn everything off before cleaning.**

Now test the controller to see if proper operation is restored. If so, take steps to prevent this from happening again: dirt and water **must** be kept from reaching the terminal area of the controller. If the voltages are still out of range, the controller is at fault and should be replaced.

**TEST 4 Check for controller output**

- 4-A** The first step is to measure the output drive voltage to the motor at the controller's M- terminal.
- 4-B** Connect the voltmeter (+) lead to the controller's B+ terminal. Connect the voltmeter (-) lead to the controller's M- terminal.
- 4-C** Turn on the keyswitch with the forward/reverse switch in neutral, and then select a direction and watch the voltmeter as you depress the pedal. The voltmeter should read zero (or close to zero) before you apply the pedal, and should read full battery voltage with the pedal fully depressed. If it does not, the controller is defective and must be replaced.
- 4-D** The next step is to measure the current in the controller's M- lead. If you have a means of measuring this high dc current, such as a shunt/meter setup or a clamp-on dc ammeter, use it. If not, we recommend that you buy an inexpensive ammeter of the type that is simply held against the wire being tested. These are readily available at auto parts stores, and their accuracy is adequate for this test.
- 4-E** Turn on the keyswitch with the forward/reverse switch in neutral, and then select a direction and watch the ammeter while depressing the pedal.
- 4-F** If you see no current flowing in the M- lead, the problem is an open circuit in the motor or the wiring between the motor and the controller. Check the forward/reverse switch. If your vehicle uses contactors for reversing, check to see that they are operating and that their contacts are closing. If these are okay, check the motor armature and field for opens.
- 4-G** If you do see a high current flowing in the M- lead, but the motor does not turn, the problem is a short in the motor circuit, a miswired motor, or a short in the controller's internal plug diode. Test the plug diode as follows:
1. Remove power by opening the battery circuit. Take the cable off the controller's A2 terminal.

2. Use an ohmmeter to check the resistance between the controller's A2 and B+ terminals. You are testing for the presence of a diode inside the controller, so swap the two leads of the ohmmeter and look for a low resistance one way and a much higher one the other way. If your meter has a diode test function, use it.
3. If you find the diode to be shorted, the controller is defective.

**4-H** Put the A2 cable back on the controller and reconnect the battery.

**4-I** If the plug diode is okay, there is a short in the motor circuit. The short could be in the forward/reverse switch, so look there first. Because the resistance of the motor is so low, the motor must be tested separately if it is suspected of having a shorted winding.

## BENCH TESTING

First, before starting any bench testing, pick up the controller and shake it. If anything rattles around inside, the unit should be returned.



**Protect yourself during bench testing.** Wear safety glasses and use insulated tools.

### Equipment Needed

The simple setup shown in Figure 20 is required for testing these controllers on the bench. You will need:

1. a POWER SUPPLY with a voltage equal to the rating of the controller you want to test. You can use either a string of batteries or a regulated line-operated power supply. Because only low power tests will be described, a 10 amp fuse should be wired in series with the batteries to protect both operator and controller against accidental shorts. A battery charger alone should not be used as a power supply, because without a battery load its output voltage may exceed the rating of the controller.
2. an ACCELERATOR POTBOX. For controllers with the standard input configuration (a 5 k $\Omega$  pot wired as a two-terminal rheostat), a Curtis PMC potbox or any 5 k $\Omega$  pot will work fine.

For controllers with other input options, use whatever kind of potbox is used on the vehicle.

3. a POWER SWITCH to disconnect all power from the test setup.

4. a MAIN CONTACTOR with a 250 ohm, 5 watt resistor across its high-power contacts and a KEYSWITCH to turn it on and off.

5. a TEST LOAD consisting of incandescent light bulbs wired in series to get the same voltage as your power supply. (For example, with a 36 volt battery, use three 12 volt bulbs.)

6. a general purpose VOLT OHMMETER or DIGITAL VOLTMETER.

**Fig. 20** Setup for bench testing.

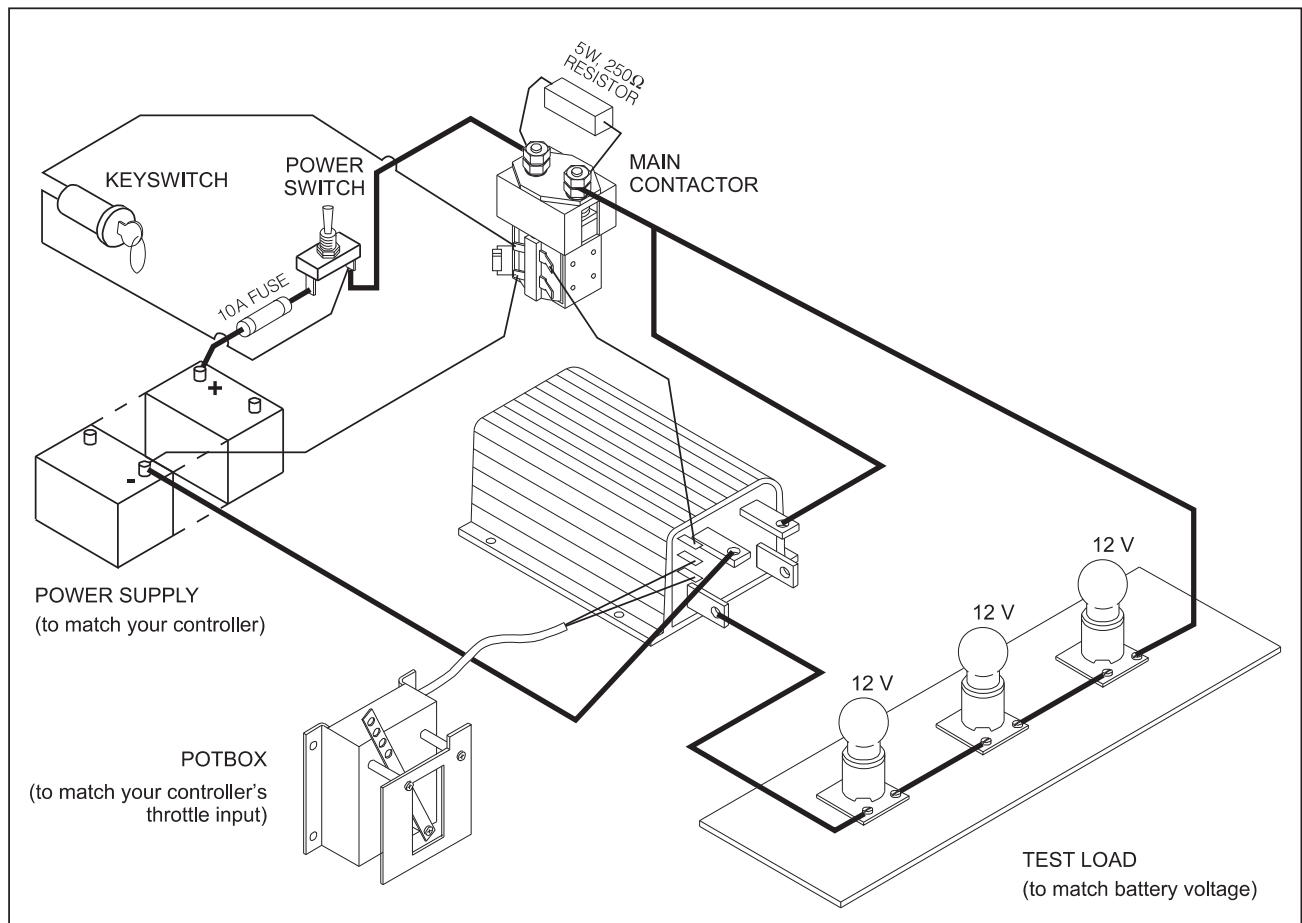

### Bench Test Procedure

- A. Hook up the controller as shown. Connect the voltmeter leads to the controller's B+ and B- terminals.
- B. Turn on the power switch (not the keyswitch) and watch the voltmeter. Its reading should build up slowly over several seconds to within a couple of volts of full battery voltage. If this voltage does not come up, the controller is bad.
- C. Now turn on the keyswitch. The main contactor should turn on and the voltage at the controller's B+ and B- terminals should now equal the full battery voltage. Move the potbox lever through its range. The lamps should go smoothly from full off to full on with the pot.
- D. If the controller has HPD, test this feature as follows:
  - 1. Turn off the keyswitch.
  - 2. Move the potbox lever about halfway.
  - 3. Turn the keyswitch switch on. Verify that the lamps do not come on until the potbox lever is moved most of the way toward OFF and then moved back up.
- E. Test the controller's potbox fault protection feature by pulling off one of the potbox's two connections to the controller's throttle input terminals while the lamps are on (potbox lever in the ON position). The lamps should turn off. With the potbox lever still in the ON position, reconnect the wire. The lamps should smoothly increase in brightness to their previous level.
- F. Finally, remove the controller from the test setup and check its internal plug diode, as described in Troubleshooting Procedure **4-G**.



# 6

## GLOSSARY: FEATURES and FUNCTIONS

### Acceleration rate

A built-in acceleration rate circuit maintains a maximum rate of power increase to the motor. If the throttle is applied full on at start-up, the acceleration rate setting determines how quickly the controller output increases. The standard setting is such that with the throttle full on, the controller requires approximately one second to reach full output. This feature contributes to smooth, gentle starts.

On some 1204/1205 models, the acceleration rate is adjustable via an externally accessible trimpot. See Section 4 for adjustment instructions. The deceleration rate is fixed, and cannot be adjusted.

### Accelerator pot fault protection (runaway protection)

To prevent uncontrolled operation, these controllers shut off the motor in the event of an open circuit fault in the accelerator potentiometer or its wiring. The standard configuration is a two-wire pot ranging from 0 ohms for full off to 5000 ohms for full on; if the controller detects an abnormally high accelerator input (more than about 1.5 times the normal input resistance), it shuts off its output to the motor, thus preventing a runaway. The controller returns to normal operation when the fault (e.g., broken potbox wiring, broken connectors) has been repaired.

### Current limiting

Curtis PMC controllers limit the motor current to a preset maximum. This feature protects the controller from damage that might result if the current were limited only by motor demand.

In addition to protecting the controller, the current limit feature also protects the rest of the system. By eliminating high current surges during vehicle acceleration, stress on the motor and batteries is reduced and their efficiency and service life are improved. Similarly, there is less wear and tear on the vehicle drivetrain, as well as on the ground on which the vehicle rides (an important consideration with golf courses and tennis courts, for example).

### Current multiplication

During acceleration and during reduced speed operation, the Curtis PMC controller allows more current to flow into the motor than flows out of the

battery. The controller acts like a dc transformer, taking in low current and high voltage (the full battery voltage) and putting out high current and low voltage. The battery needs to supply only a fraction of the current that would be required by a conventional controller (in which the battery current and motor current are always equal). The current multiplication feature gives vehicles using Curtis PMC controllers dramatically greater driving range per battery charge.

### **Environmental protection**

Curtis PMC 1204 and 1205 controllers are housed in rugged anodized aluminum extrusions that provide environmental protection. Controllers must be kept clean and dry, however, to ensure long life.

### **High pedal disable (HPD)** [OPTIONAL FEATURE]

By preventing the vehicle from being turned on with the throttle applied, HPD ensures the vehicle starts smoothly and safely. If the operator attempts to start the vehicle when the throttle is already applied, the controller (and the vehicle) will remain off. For the vehicle to start, the controller must receive an input to KSI before receiving a throttle input. In addition to providing routine smooth starts, HPD also protects against accidental sudden starts if problems in the pedal linkage (e.g., bent parts, broken return spring) give a throttle input signal to the controller even with the pedal released.

The 1204 and 1205 controllers are available either with or without the HPD feature.

### **KSI**

KSI (Key Switch Input) provides power to the controller's logic board via both the keyswitch and the footpedal microswitch. For vehicles that have no keyswitch, KSI is routed through the footpedal microswitch. For non-vehicle applications (such as conveyor belts), KSI may simply be tied to B+.

### **MOSFET**

A MOSFET (Metal Oxide Semiconductor Field Effect Transistor) is a type of transistor characterized by its fast switching speeds and very low losses.

### **Overtemperature**

See *Thermal protection*.

## Plug braking

The vehicle can be braked electrically by selecting the opposite direction with the forward/reverse switch without releasing the throttle. When the motor is reversed, the armature acts as a generator; the controller regulates the current in the motor field winding to give an appropriate level of plug braking torque. The vehicle brakes smoothly to a stop, then accelerates in the other direction. (NOTE: The controller may be unable to provide plug braking if the vehicle is moving too slowly for the motor to generate the necessary plug braking current.)

The plug current limit is factory set to meet customer requirements. On some 1204/1205 models, the plug current limit is adjustable via an externally accessible trimpot. See Section 4 for adjustment instructions.

If plug braking is not desired, the vehicle can be wired so that moving the forward/reverse switch through neutral causes the vehicle to freewheel as long as the accelerator is applied. If the throttle is released and reapplied, plug braking will then occur. To inhibit plug braking in this way, your controller must have the optional HPD feature. Wiring details are provided in Section 3.

A 1 kHz tone may be heard during plug braking.

## PWM

PWM (Pulse Width Modulation), also called “chopping,” is a technique that switches battery voltage to the motor on and off very quickly, thereby controlling the speed of the motor. Curtis PMC 1200 series controllers use high frequency PWM — 15 kHz — which permits silent, efficient operation. PWM is described in more detail in Appendix B.

## Smooth, stepless operation

Like all Curtis PMC 1200 Series controllers, the 1204 and 1205 models allow superior operator control of the vehicle’s drive motor speed. The amount of current delivered to the motor is set by varying the “on” time (duty cycle) of the controller’s power MOSFET transistors. This technique — pulse width modulation — permits silent, stepless operation. Pulse width modulation is described in Appendix B.

## Thermal protection

Because of their efficiency and thermal design, Curtis PMC controllers should barely get warm in normal operation. Overheating can occur, however, if the controller is undersized for its application or otherwise overloaded. If the internal temperature of the controller exceeds 75°C (167°F), the current limit decreases to approximately half its rated value.

At the reduced performance level, the vehicle can be maneuvered out of the way and parked.

Full current limit and performance return automatically after the controller cools down. Although this action is not damaging to the controller, it does suggest a mismatch. If thermal cutback occurs often in normal vehicle operation, the controller is probably undersized for the application and a higher current model should be used.

The controller is similarly protected from undertemperature. Should its internal temperature fall below  $-25^{\circ}\text{C}$  ( $-13^{\circ}\text{F}$ ), the current limit decreases to approximately half of the set current. When the controller warms up, full current limit and performance return automatically.

### **Undertemperature**

See *Thermal protection*.

### **Undervoltage protection**

The control circuitry requires a minimum battery voltage to function properly. The controller is therefore designed so its output is gradually reduced if the battery voltage falls below a certain level. Cutback voltages for the various models are listed in the specifications (Appendix C). Reducing the output to the motor allows the battery voltage to recover, and an equilibrium is established in which the battery supplies as much current as it can without falling below the cutback voltage.

# APPENDIX A

## FUNCTIONAL DESCRIPTION

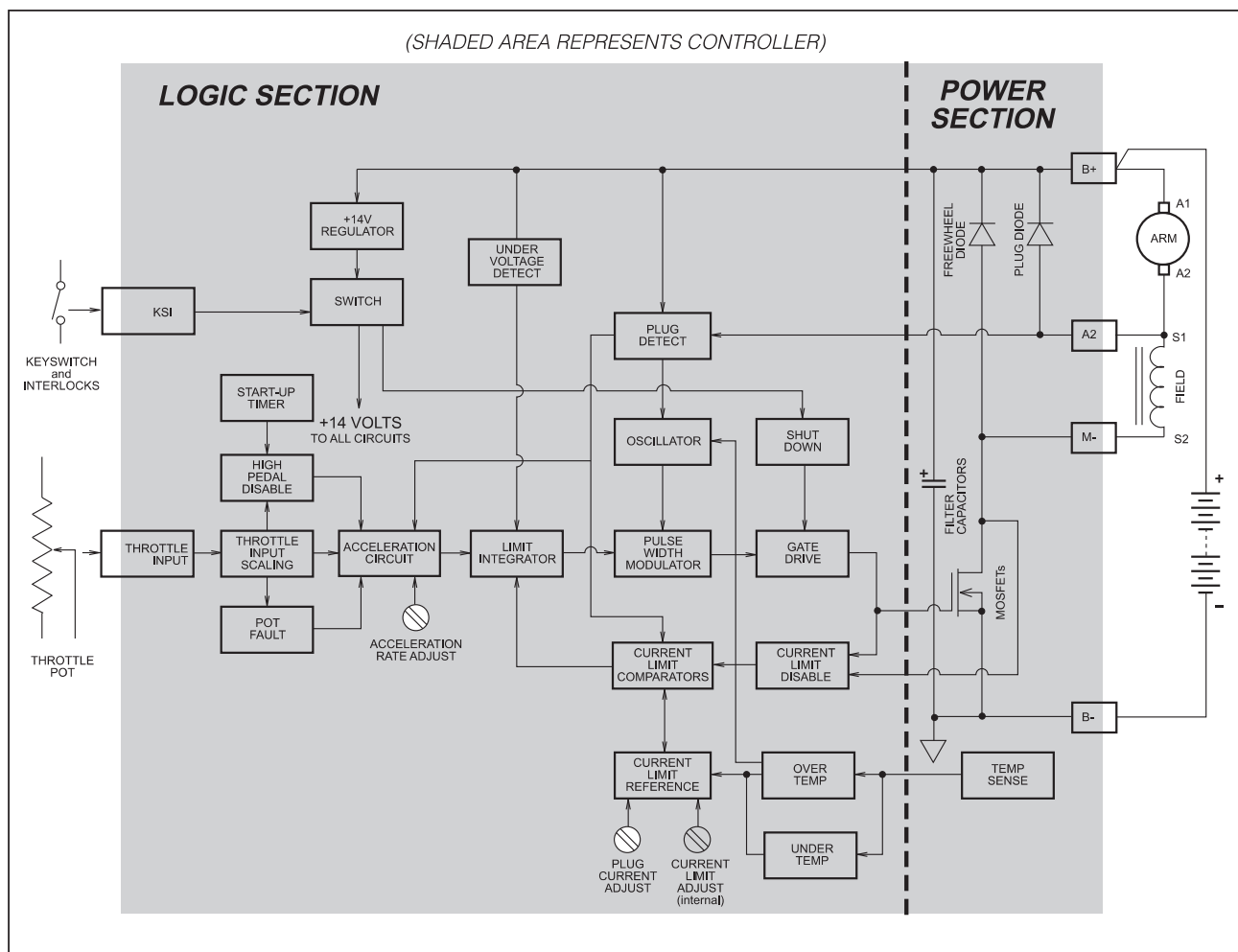

Fig. A-1 Block diagram, Curtis PMC 1204/1205 controllers.

The controllers consist of a **POWER SECTION** and a **LOGIC SECTION**.

### POWER SECTION

An array of paralleled power metal oxide semiconductor field effect transistors (MOSFETs) switches pulses of current from the battery to the motor. During the interval when the MOSFETs are off, the motor current continues to flow in the freewheel diode, which is actually a number of paralleled fast recovery rectifiers. An array of filter capacitors connected directly across the battery provides the instantaneous current required by the power switching circuitry and in this way provides battery ripple current filtering and voltage spike suppression. The plug diode provides a path for armature current to flow during plug braking of series motors. In versions of these

controllers for use with PM motors only, the plug diode and A2 terminal are omitted; however, the Functional Description is written in terms of series motors.

## LOGIC SECTION

B- is the ground return for all of the logic circuitry. For systems over 12 volts, the battery supply is regulated down to 14 volts to power the logic circuitry. The output of the 14 volt regulator is switched on and off (switch) by the keyswitch input (KSI) to power up the control circuitry when the vehicle is in use and to power it down (shutdown) when the vehicle is not in use.

The speed control input (throttle input) is usually a 5000 ohm, two-wire pot, but other types can be accommodated, so a flexible throttle input scaling circuit conditions the control input to a standard level. This standardized throttle input goes to the acceleration circuit which limits the rate at which the controller output can increase. The acceleration rate is set by a resistance, and is adjustable via a user accessible trimpot (acceleration ramp adjust).

The output of the throttle input scaling also goes to a pot fault circuit which turns the controller output off in the event of inputs (e.g., broken wires) which would otherwise cause a runaway. An optional protective feature, high pedal disable (HPD), inhibits controller output if the controller is turned on with the throttle applied. After an interval measured (start-up timer) from the moment the KSI input is turned on, the HPD circuit checks the throttle position. If an applied throttle condition is detected, controller output is held off until the throttle input is returned to zero and then normal operation is allowed.

The control signal then goes to the limit integrator which reduces the controller output in response to undervoltage or overcurrent. The time-averaged response of this circuit gives a stable limiting action. The undervoltage detector gives an output when the battery voltage is too low. The reduction in output allows the battery voltage to recover and an equilibrium to be established at a voltage high enough to allow the controller to function properly. The current limit function is explained in more detail below.

The heart of the logic circuitry is the pulse width modulator in which the control input derived from the previous stages is compared in magnitude to a 15 kHz sawtooth wave from the oscillator. The resulting pulse output can be smoothly varied between full off and full on. These pulses become the input to the controller's main power MOSFET switch via a gate drive circuit that provides the high pulse currents needed to turn the power MOSFETs on and off (see Fig. B-1). The shape of the sawtooth wave may be altered so that most of the pulse width change occurs in the earlier or in the latter part of the control input range, giving more sensitive throttle response at high or at low speeds.

Current limiting is done by sensing the voltage drop across the main power MOSFET switch when it is on. This voltage is compared (current limit comparators) with a current limit reference; when it exceeds the reference, an overcurrent signal acts on the limit integrator to reduce the controller

output and thus hold the current at the limit. Because the voltage across the power MOSFET switch is high when it is off, the current limit comparison is inhibited during the off interval by the current limit disable circuit. The current limit is set as follows:

1. During manufacture, the current limit is set by an internal trimpot (current limit adjust) to the model's nominal rating.
2. During operation at extreme high or low temperatures, current limit is reduced to protect the controller from damage. From a thermal sensor (temp sense) on the heatsink, signals are produced to cut back the current limit at temperatures above 75°C or below -25°C (overtemp, undertemp).
3. During plug braking operation, the current limit is reduced to give an appropriate motor braking torque. The plug braking current is set during manufacture; it is also user-adjustable by a trimpot (plug current adjust). The plug current limit reference is derived from the current limit reference.

The transition to the plug braking mode is detected (plug detect) by monitoring the voltage across the plug diode. When this diode becomes forward biased, it indicates that the motor field has been reversed and the controller has gone into plug mode. The current limit is reduced as described, and the frequency of the oscillator is reduced from 15 kHz to 1 kHz, to allow finer control of the controller output while plugging. During plug braking operation, the acceleration circuit is reset to a low level so that when drive operation resumes, the controller will go through a normal acceleration ramp. When the motor has come to a stop, the plug diode will again become reverse biased and the controller will revert to normal drive operation.





## APPENDIX C

### SPECIFICATIONS

NOMINAL INPUT VOLTAGE	12V, 24–36V, and 36–48V
PWM OPERATING FREQUENCY	15 kHz
STANDBY CURRENT	less than 20 mA
STANDARD THROTTLE INPUT	5 k $\Omega$ $\pm$ 10% (others available)
WEIGHT	1204: 1.8 kg (4 lbs)      1205: 2.7 kg (6 lbs)
DIMENSIONS	1204: 146mm $\times$ 170mm $\times$ 70mm (5.75" $\times$ 6.75" $\times$ 2.8") 1205: 146mm $\times$ 222mm $\times$ 70mm (5.75" $\times$ 8.75" $\times$ 2.8")

MODEL NUMBER	NOMINAL BATTERY VOLTAGE (volts)	CURRENT LIMIT (amps)	2 MIN RATING (amps)	5 MIN RATING (amps)	1 HOUR RATING (amps)	VOLTAGE DROP @ 100 AMPS (volts)	UNDER-VOLTAGE CUTBACK (volts)
<b>1204-0XX</b>	24–36	275	275	200	125	0.35	16
-1XX	24–36	175	175	130	75	0.50	16
-2XX†	24–36	275	275	200	125	0.35	16
-3XX†	24–36	175	175	130	75	0.50	16
-4XX	36–48	275	275	200	125	0.35	21
-5XX	36–48	175	175	130	75	0.50	21
-6XX	12	275	275	200	125	0.35	9
-7XX	12	175	175	130	75	0.50	9
<b>1205-1XX</b>	24–36	400	400	275	175	0.25	16
-2XX	36–48	350	350	250	150	0.30	21
-3XX	12	400	400	275	175	0.25	9

† Models for use with permanent magnet motors (no A2 bus bar provided).