

↑
SIDE SHIFT
4" EACH WAY
↓

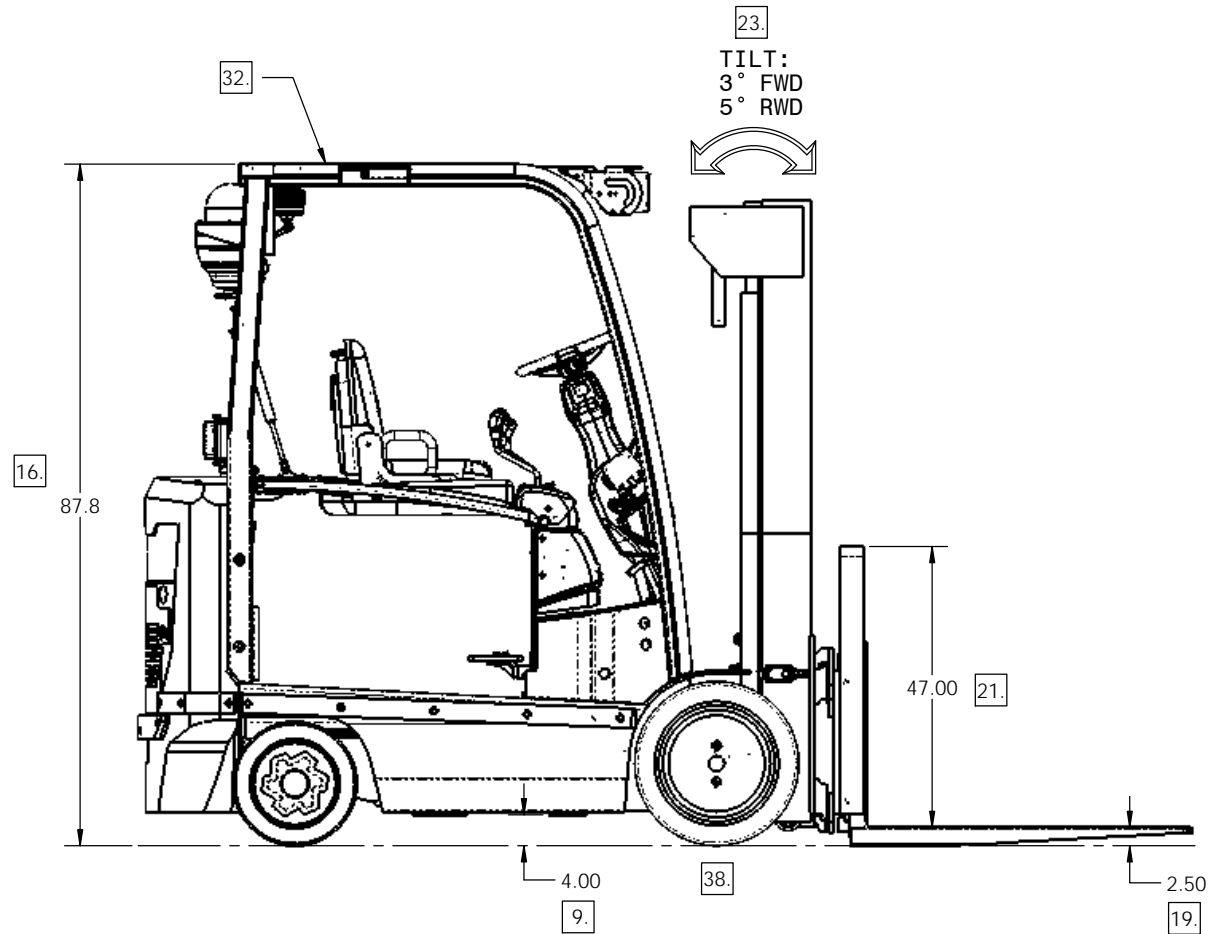

PRELIMINARY DRAWING APPROVAL (CHECK APPROPRIATE BOX):
 APPROVED (NO EXCEPTIONS TAKEN).
 APPROVED AS NOTED (RESUBMISSION NOT REQUIRED).
 REVISE AND RESUBMIT.
 NOTES:
 1. FAILURE TO SIGN AND RETURN THIS DRAWING WITHIN FIVE (5) BUSINESS DAYS WILL RESULT IN DELAYS TO QUOTED DELIVERY DATE (ELECTRONIC APPROVALS ARE ACCEPTED).
 2. CHANGES MAY RESULT IN ADDITIONAL FEES AND/OR DELAYS.
 3. BATTERY INFORMATION MUST BE SUBMITTED AT TIME OF FINAL APPROVAL. FAILURE TO SUPPLY REQUIRED INFORMATION WILL RESULT IN DELAYS TO THE QUOTED DELIVERY DATE. (IF BPR/RICO IS SUPPLYING THE BATTERY, THIS DOES NOT APPLY.)
 4. DIMENSIONS ARE IN ACCORDANCE WITH ASME Y14.5-2009.
 5. ANY ADDITIONAL DIMENSIONAL AND/OR TOLERANCE REQUIREMENTS MUST BE SPECIFIED BY CUSTOMER. FAILURE TO SUPPLY REQUIRED INFORMATION AT TIME OF APPROVAL WILL RESULT IN DELAYS TO QUOTED DELIVERY DATE.
 APPROVED BY: _____
 DATE: ____/____/____
 COMPANY: _____

TRUCK SPECIFICATIONS (MODEL NUMBER T-10152)

1	MODEL	DSD-EX-AC-60
2	RATING	BUILT TO UL 583 TYPE "EX", FM APPROVED, CLASS I-D, II-G, DIV 1
3	CAPACITY	5,450 LBS (UP TO 156" OF LIFT)
4	TRUCK VOLTAGE	36 VDC
5	LOAD CENTER	24"
6	DRIVE END TYPE	SIT-DOWN RIDER
7	DRIVE QTY	SINGLE DRIVE AXLE
8	RIDER ENTRY	SIDE, LEFT
9	UNDER-CLEARANCE	4"
10	DRIVE TIRE	TWO (2) 21" X 8" RUBBER
11	LOAD WHEELS	TWO (2) 16" X 6" STATIC CONDUCTIVE RUBBER
12	STEERING	POWER
13	HYDR CONTROLS	MANUAL LEVER STYLE SPOOL VALVE
14	BATTERY REMOVAL	SIDE, RIGHT
15	TRAVEL SPEED	4.5 MPH EMPTY (± .5 MPH)
16	OVERHEAD GUARD	87.8"
17	COLOR	SAFETY ORANGE
18	FORK CLASS	ITA III
19	FORK LOWERED HEIGHT	2.5"
20	CARRIAGE WIDTH	40.5"
21	LOAD BACKREST HEIGHT	47"
22	SIDE SHIFT	4" EACH WAY (8" TOTAL TRAVEL)
23	TILT	3° FORWARD, 5° BACK
24	CHASSIS LENGTH	93.8" TO FACE OF FORKS
25	CHASSIS WIDTH	44.5" NARROW TRACK; (SEE MAST OPTIONS)
26	ZERO CLEARANCE TURN RADIUS	80.1"
27	ZERO CLEARANCE RIGHT ANGLE STACK	154.8" W/40" X 48" PALLET
28	SAFETY FEATURES	BDI/HOUR METER W/ LIFT CUTOUT
29		DEAD-MAN BRAKING
30		EMERGENCY POWER DISCONNECT
31		HORN
32		OVERHEAD GUARD
33		SEATBELT

TRUCK OPTIONS

34	STROBE LIGHT	
35	SS FORK POSITIONER	ITA CLASS III; 41" WIDE; 4" SIDE SHIFT EACH WAY
36	WORK LIGHT PACKAGE	TWO FORWARD HEADLIGHTS - ONE REARWARD BLUE SAFETY LIGHT
37	BATTERY GATE	
38	LUGGED TIRES	

UOS, DIM ARE IN INCHES. .X ± .1 .XX ± .04 .XXX ± .010 ANGULAR ± 1° INTERPRET DIM AND TOL PER ASME Y14.5-2009.	THIS DOCUMENT CONTAINS PROPRIETARY INFORMATION AND NEITHER IT NOR THE INFORMATION CONTAINED THEREIN SHALL BE DISCLOSED OR DUPLICATED WITHOUT THE EXPRESS WRITTEN CONSENT OF BPR/RICO MFG INC.		MFG PROCESS SALES TEMPL FOR GENERAL MFG PROCESSES		 TITLE DSD-EX-AC-60	
	THIRD ANGLE PROJECTION 	DRAWN BY 3/21/2017	ENGINEER MB 3/21/2017	SIZE C SCALE 1:16		

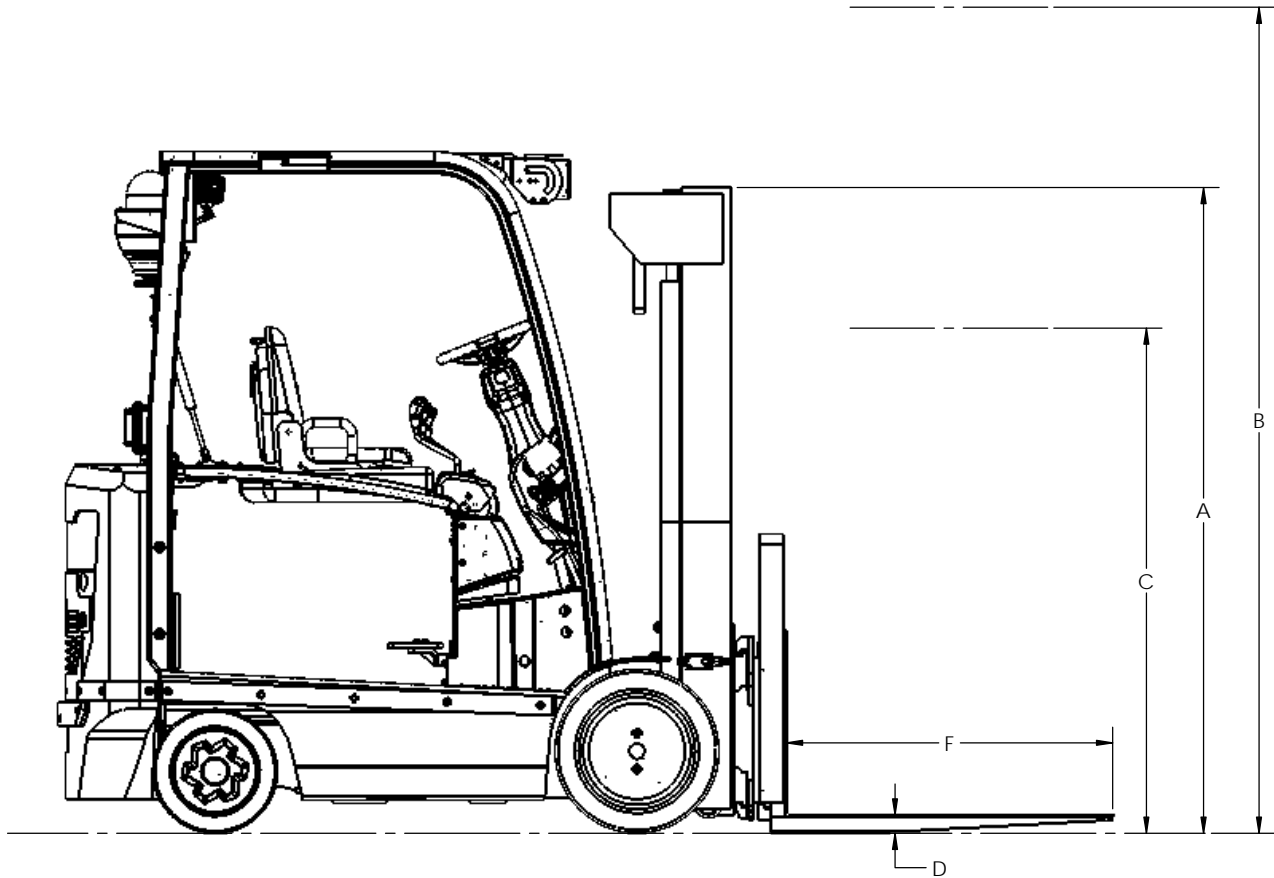
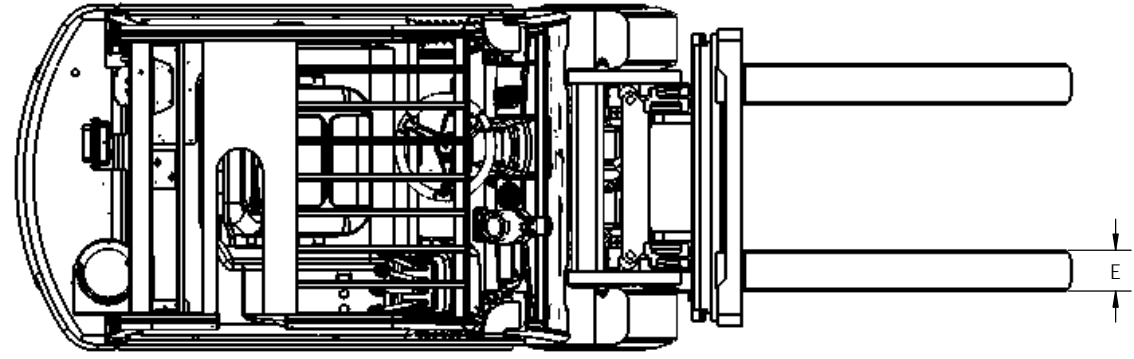

SEE SHEET 2 FOR ADDITIONAL OPTIONS

T10175PD
D
C
B
A



REVISIONS				
ZONE	REV.	DESCRIPTION	DATE	APPROVED

MAST OPTION 1 (83/186/63)		
A	MAST HEIGHT	83"
B	RAISED HEIGHT	186"
C	FREE LIFT	63"
MAST OPTION 2 (97/219/77)		
A	MAST HEIGHT	97"
B	RAISED HEIGHT	219"
C	FREE LIFT	77"
MAST OPTION 3 (103/237/83)		
A	MAST HEIGHT	103"
B	RAISED HEIGHT	237"
C	FREE LIFT	83"
MAST OPTION 4 (83/127/63)		
A	MAST HEIGHT	83"
B	RAISED HEIGHT	127"
C	FREE LIFT	63"
FORK OPTION 1		
D	THICKNESS	2.25" W/BRASS CLADDING
E	WIDTH	5.25" W/BRASS CLADDING
F	LENGTH	42" W/BRASS CLADDING
FORK OPTION 2		
D	THICKNESS	2.25" W/BRASS CLADDING
E	WIDTH	5.25" W/BRASS CLADDING
F	LENGTH	48" W/BRASS CLADDING

UOS, DIM ARE IN INCHES. .X ± .1 .XX ± .04 .XXX ± .010 ANGULAR ± 1° INTERPRET DIM AND TOL PER ASME Y14.5-2009.	THIS DOCUMENT CONTAINS PROPRIETARY INFORMATION AND NEITHER IT NOR THE INFORMATION CONTAINED THEREIN SHALL BE DISCLOSED OR DUPLICATED WITHOUT THE EXPRESS WRITTEN CONSENT OF BPR/RICO MFG INC.	MFG PROCESS	
		SALES	
THIRD ANGLE PROJECTION	DRAWN BY	ENGINEER	TITLE
	3/21/2017	MB	DSD-EX-AC-60
			DRAWING NUMBER T10175PD
			REV LEVEL SHEET 20F2
		SCALE 1:16	WEIGHT 11254.7 LB

T10175PD