



**RICO**

RICO Manufacturing, Inc.  
691 West Liberty  
Medina, OH 44256

Phone 330.723.4050  
Fax 330.723.4012

[www.RicoEquipment.com](http://www.RicoEquipment.com)

MATERIAL HANDLING REDEFINED.

**RICO**



CAPACITIES UP TO 120,000 LBS  
IN A WIDE VARIETY OF STYLES.



**RICO**



**RICO**

INNOVATIVE SOLUTIONS FOR MATERIAL HANDLING

OUR REPUTATION AS A PIONEER IN  
**Design & Development**

RICO is a leading manufacturer of engineered material handling equipment. Our 130 years of expertise in this industry has resulted in RICO'S reputation as a pioneer in the design, development, and creation of equipment with capacities from 1,000 to 400,000 pounds.

With our headquarters located in Medina, Ohio, our major client base is involved in industrial, commercial, automotive and military markets and our products are used around the globe.

We are very proud to be one of the most self-sufficient companies in this industry. With over 98 % of our work performed in-house from design to fabrication to assembly, we are truly unique in the material handling equipment manufacturing arena.

That means you get:

- Quicker Delivery,
- Flexible Production Schedules,
- Rapid Prototyping,
- High Standards for Quality,
- Increased Equipment Reliability,
- The HIGHEST Level of Tech Support.

That is the **RICO ADVANTAGE.**

FLEXIBILITY. VERSATILITY. EFFICIENCY.

# Outstanding Performance



INNOVATIVE SOLUTIONS FOR MATERIAL HANDLING

All Rico trucks prove that it's not the size of the load that matters, but how well your lift truck is suited for the application.

Rico has built a reputation on building the strongest and reliable truck in the industry. Reach, Straddle and Counterbalance trucks are designed in 3 versions: Walk Behind, Stand Up or Sit Down riders with each offering its own unique features. In either case, the operator has more confidence through operator comfort, control, and visibility.

On the high lift truck series, every feature is matched by serviceability and excellence in design. No matter how big or small your job, performance is of the highest priority. Features include...

- AC or DC drive systems
- Stationary mounted dual or single drive motors
- Helical beveled transmission
- Power Steering or Manual steer options
- Integral side-shift fork positioning

Flexibility, Versatility, Efficiency are all trademarks of Rico and are incorporated into our designs. In true Rico style, our high lift trucks are manufactured with various lift heights, capacities, and control options to handle a diverse list of applications.

## SUPERIOR PERFORMANCE & RELIABILITY

The Rico drive system is powered by programmable controllers that feature on-board service diagnostic and on-site customizable capability. Maximum travel and creep speed are just two of the many controller settings that are adjustable.

Performance is maximized by High torque drive motors that are coupled with vertically mounted transmissions providing a strong combination of power and reliability. Motors are equipped with large surface contact rotors in either mechanical or electric brake design providing safe and secure stopping each and every time.

We use A36 plate and high strength structural steel on all welded frames. Strong, preheated, multiple-pass frame welds specifically designed for the most severe operating conditions are a trademark of the Rico Product Family.

The mast design incorporates a wide, upright spread to allow for easy, accurate load spotting. We maximize the strength of the mast by utilizing rolled or machined forgings. High-strength forged forks are designed to meet your specific load and application requirements.

Safety is maximized through low profile drive ends for operator visibility and for easy, accurate load spotting. Walk behind models have integrated emergency reversing switch, thumb throttle speed controls and high speed cut back switch for operator safety. Rider models feature console mounted power disconnects and an operator presence detection sensor that prevents inadvertent operation of the vehicle.

## SIMPLE MAINTENANCE

All vehicles are designed with maintenance and service in mind to prolong the life of the equipment and sustained trouble free operation. Rico's focus on serviceability is reflected in...

- Large Access Points for hydraulic and electrical system
- A central lubrication system
- Battery Discharge Indicators to prolong battery life
- Drop out load wheel housing
- On-board service diagnostic of drive system

Less time spent on maintenance results in increased run time, higher productivity, and a rapid return on investment.

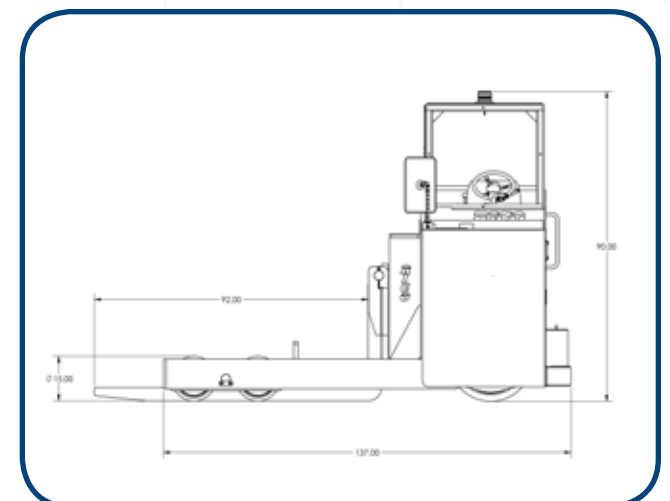
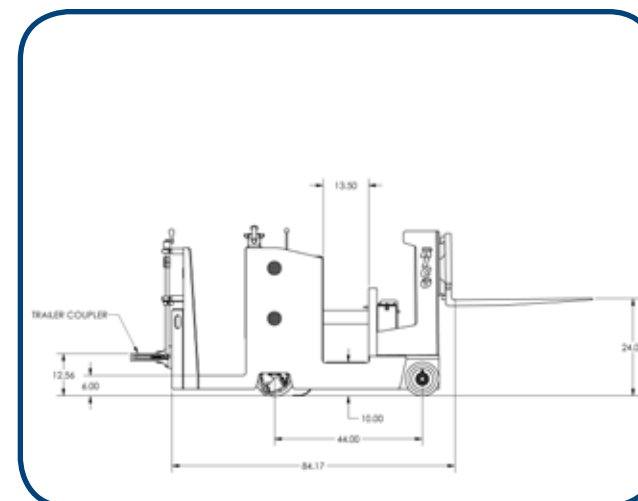

*Rico's trucks are a true innovative solution for your material handling needs.*

*The type of real solution to real problems you face as a company.*

*The type of solution you have come to expect from RICO.*

*For more information about this product or any of the other solutions we provide, please contact us at: 330-723-4050 or visit us online at*

*[www.RicoEquipment.com](http://www.RicoEquipment.com)*



# Stand-Up Rider Reach Series

Capacities up to 10,000 lbs



### OPERATOR CONTROLS

- Rugged ergonomic cast aluminum and pistol grip throttle control with trigger horn button.
- Emergency stop, battery discharge indicators and functions are within easy reach of the operator.
- Cast aluminum steer lever supported with large displacement steering valve and motor for minimal steering effort.



### OPERATOR COMPARTMENT

- Electric or mechanically operated foot brake control provides smooth precise stopping.
- Operator platforms include cushion hip pads, floor mat and safe presence detection switches to prevent inadvertent operation of controls.



### SERVICEABILITY

- Open compartments maximize serviceability through large access points.

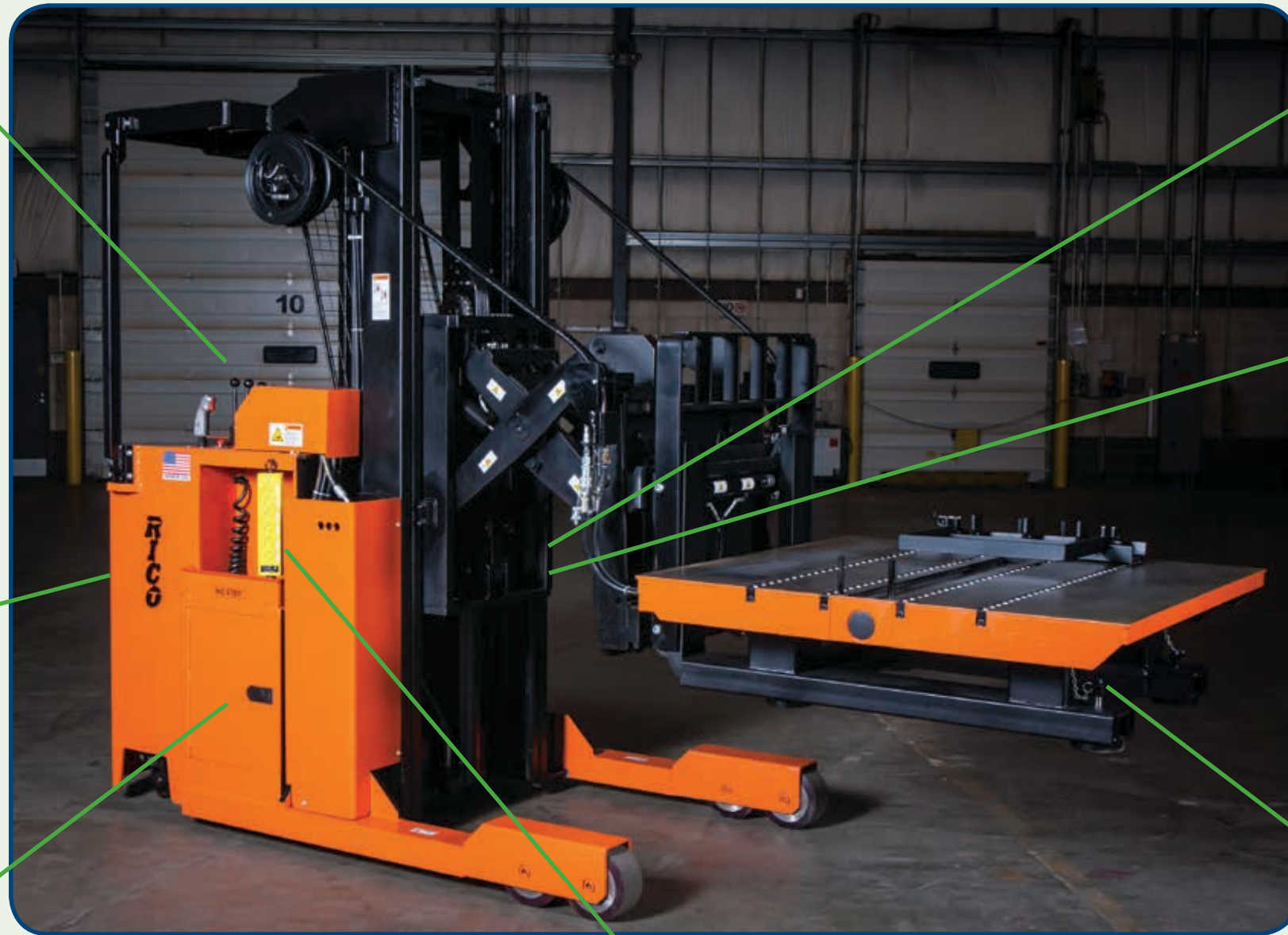

### BATTERY COMPARTMENT

- Swing-out or lift-out battery gates and rollers for rapid removal and service.
- Available in 24 or 36 volt electrical systems.



### DRIVE SYSTEM

- Stationary DC or AC motors are coupled with the strongest helical beveled gearboxes in the industry for superior performance.
- Programmable controllers are used with on-board service diagnostic capability providing energy efficiency, and infinite speed control.



### ATTACHMENTS & ACCESSORIES

- Reach Mechanisms are available in single or double reach and constructed of high-strength ASTM A514 steel plate.
- Attachments are virtually limitless and designed to meet your specific application.



### PENDANT OPTIONS

- Pendant load handling controls are offered for areas where visibility or precise positioning is a concern.



# Sit-Down Rider Straddle Series

Capacities up to 120,000 lbs



### CAB

- Customizable operator position for forward facing, side facing, rearward or rotating positioning cab design.
- Ergonomically designed cab provides adjustable positioning seat, tilt steering column, foot pedals and controls for operator comfort.



### INGRESS & EGRESS

- Oversized entryway with durable, non-slip operator and wide, deep non-skid steps allows for safe entrance and exit of cab.
- Seat-mounted operator presence detection to prevent inadvertent operation of controls.
- All around visibility.



### FORKS & CARRIAGE

- Heavy rolled steel mast rail provides smooth, even lifting and stability.
- High-strength forged steel forks customized to your specific application.



### DRIVE SYSTEM

- High-torque planetary gear drives coupled with electric or hydraulic brakes.
- Drive tires specified to meet your application: heavy loads, poor floors, cold environments, slick floors, non-marking, etc.



### SPECIAL MAINTENANCE OPTIONS

- Quick access central lubrication stations for slew and steering bearing for ease of service.



### SPECIAL SERVICE OPTIONS

- Hydraulic system equipped with oil level indicators and dash mounted oil temperature gauges.



### SERVICEABILITY

- Drive end equipped with multiple large access points for easy repair and replacement.
- Programmable controllers are used with on-board service diagnostic capability providing energy efficiency, and infinite speed control.



# Walk-Behind Reach Series

Capacities up to 8,000 lbs



### MASTS

- Mast mounted Plexiglas or steel mesh provides operator protection and clear load visibility.
- The strength of our upright is maximized by utilizing heavy rolled steel mast rail that provides smooth, even lifting and stability.



### DRIVE AND STEERING SYSTEM

- Hydraulic driven torque generator system allows for precise handling and superior steering response.



### REACH MECHANISM

- Mast guide bearings with hardend heavy outer rings and sealed rubber seals provide extended maintenance free service.
- Reach Mechanisms are constructed of high-strength ASTM A514 steel plate increasing load handling stability.



### OPERATOR CONTROLS

- Manual spool valve provides infinitely variable operation of hydraulic controls functions (also available in electric operation).
- Display provides hour meter, battery discharge indicator and system trouble code tracking for ease of service.



### SAFETY

- Ergonomic multifunction handle control can be equipped with push button functions, emergency safety reversing and large central horn button for safe operation.
- Steel covers provide unmatched protections of internal components.



### HYDRAULIC SYSTEM

- Easy access hydraulic fills with dipstick design for quick oil verification.



### DRIVE SYSTEM

- High torque stationary motors reduce cable fatigue and wear requiring less maintenance.



# Walk-Behind Counterbalance Series

Capacities up to 10,000 lbs



### CAPACITIES AND HEIGHTS

- Lifting capacity and heights are custom engineered to meet your specific application and load requirements.



### SIDE SHIFT

- Fully integrated fork positioner for maximum lifting capacities.



### SAFETY

- Heavy rolled steel mast rail provides smooth, even lifting and stability.
- Mast guide bearings with hardened, heavy outer rings, precision ground, deep groove ball tracks, and rubber lip seals for extended maintenance free usage.

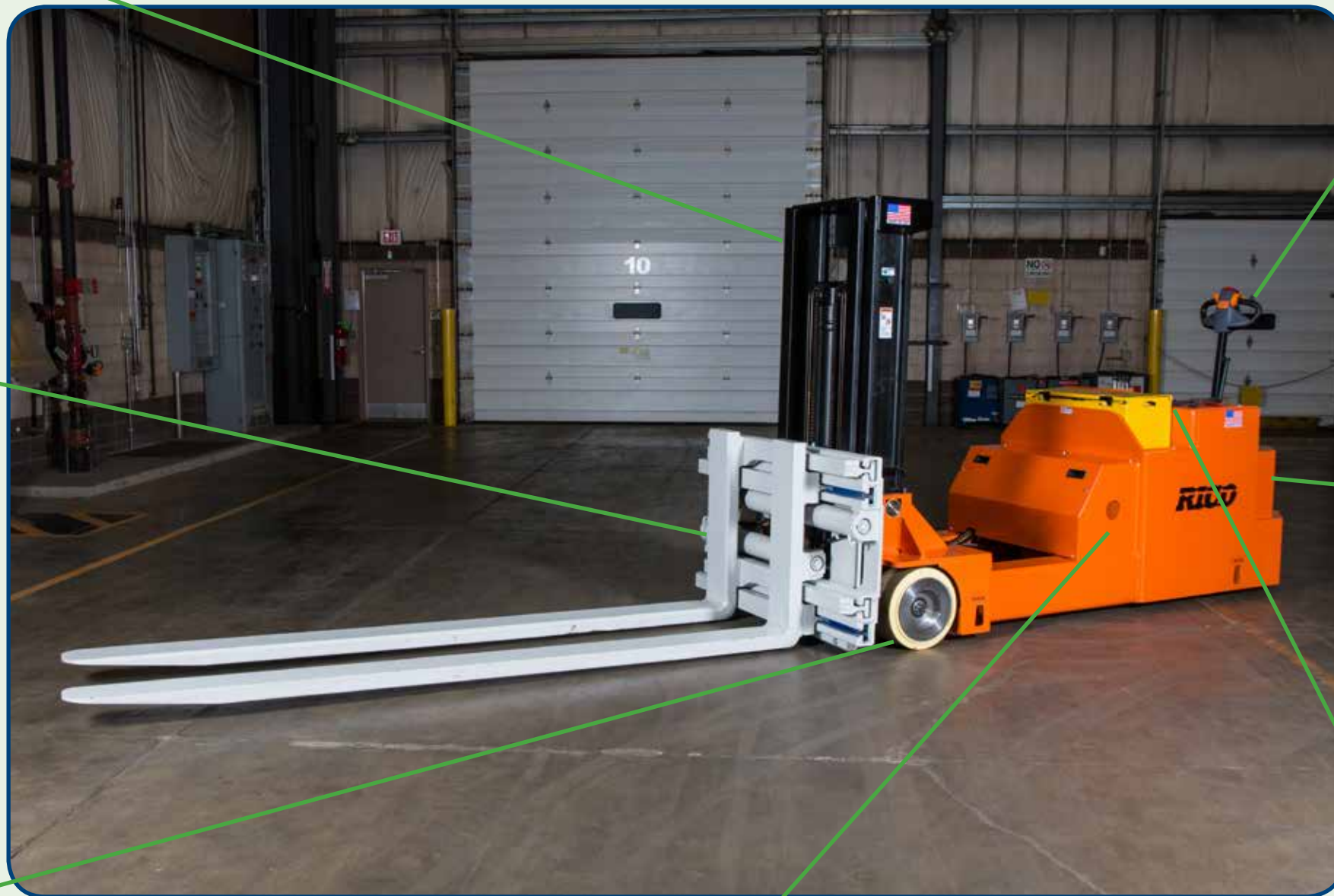

### HYDRAULIC SYSTEM

- Hydraulic system design with large reservoir for additional oil capacity reducing heat buildup.
- Heavy duty motor and gear pump provide sufficient power to lift even the largest of loads.



### ERGONOMIC HANDLE

- Handle is equipped with Ergonomic thumb travel control. Multifunctional safety controls include emergency safety reversing, horn and power steering.
- Hydraulic pilot operated controls provide precise positioning of lift, lower and fork positioning.



### DRIVE SYSTEM

- High Torque Stationary Drive motors available in DC or AC motors.
- Helical bevel gearboxes with double-bearing supported drive pinions.
- Open Drive compartment maximizing serviceability.



### VISIBILITY

- Narrow mast upright design allows for optimal visibility for maximum operator safety.





3K Cradle Straddle



3K EE Straddle



8K Reach



8K Reach



4K Inverted Forks



4K Side Reach



12K Fork Positioning Load Pusher



20K Over Truck Straddle



5K Engine Positioner



6K Barrel Clamping Counterbalance



30K Frame Handling Straddle



3K Bundle Clamping Counterbalance



6K Rotating Positioning Reach



8K Inverted Fork Straddle



75K Remote Control Straddle



80K Straddle