



RICCI
Lift Trucks



COMES IN ELITE STANDARD
OR SP-SERIES SPECIALTY -
AC ELECTRIC OR IC

CAPACITIES RANGING FROM
20,000 TO 80,000 LBS.

LP GAS & DIESEL VERSIONS

AC TECHNOLOGY - ELECTRIC VERSIONS

- Maintenance-free
- Brushless
- Smoother and more controlled braking on any gradient
- Enhanced acceleration and speed with or without load
- No wearable parts
- Significantly improved energy consumption
- Productivity output drastically increased



RICO INNOVATIVE SOLUTIONS FOR MATERIAL HANDLING

OUR REPUTATION AS A PIONEER IN

Design & Development

RICO is a leading manufacturer of engineered material handling equipment. Our over 130 years of combined expertise in this industry are reflected in the design, engineering, and manufacturing of the PEGASUS ELITE and PEGASUS Specialty (SP) lines, featuring load capacities ranging from 20,000 lbs. to 80,000 lbs. Multiple mast, carriage and fork combinations are available on the standard chassis to suit a wide range of applications and industries, including metals and automotive stamping and manufacturing.

RICO's design and manufacturing center is located in Medina, Ohio, where the PEGASUS line is produced. Over 98% of the design, fabrication and assembly work is handled by RICO, resulting in a high level of direct quality control and repeatability.

The PEGASUS ELITE counterbalance series is distributed by Hyster Company and supported through an extensive network of authorized Hyster® dealers, providing local coverage through their sales and service locations across the US and Canada. Visit www.hysternorthamerica.com to find your local Hyster® dealer.

- Quickest Delivery,
- Flexible Production Schedules,
- Rapid Prototyping,
- High Standards for Quality,
- Increased Equipment Reliability,
- The HIGHEST Level of Technical Support.

That is the **RICO ADVANTAGE.**

FLEXIBILITY. VERSATILITY. EFFICIENCY.

Outstanding Performance



INNOVATIVE SOLUTIONS FOR MATERIAL HANDLING

The innovative standard PEGASUS ELITE and PEGASUS Specialty (SP) counterbalance series has been created as a standard application truck in 3 versions: Electric, LP Gas or Diesel.

PEGASUS is ergonomically designed for operators and service technicians alike, making life just that much easier. With a cab forward design providing comfort and convenience, the PEGASUS is truly one of a kind.

- **Healthy Posture accomplished through semi-suspension of an air ride seat.**
- **Seat back angle, weight and adjustments are at your fingertips.**
- **An integrated seat switch, a "kill" switch allow for safe operation ONLY while seated.**
- **Tilt steering allows for comfortable operation regardless of operator's height.**
- **LED safety light package**
- **Integral side-shifting fork positioned**
- **High Visibility Carriage**

Safety is critical as we included large steps, easy to reach rails, and exits from both sides of the PEGASUS. Visibility has been maximized to improve operation by utilizing our forward cab, high visibility carriage and higher operator seat design.

Flexibility. Versatility. Efficiency. All trademarks of RICO and all incorporated into the PEGASUS. From various lift heights, capacities and options to handle any application, it has been built in true RICO style.

SUPERIOR PERFORMANCE & RELIABILITY

PEGASUS is designed for demanding applications. Through the use of thermostat controlled hydraulic oil coolers, heavy duty axle steer, coupled with the heaviest chassis ever experienced in the market, PEGASUS is truly unique.

The mast design incorporates a wide, upright spread and high visibility carriage to allow for easy, accurate load spotting. We maximized the strength of the masts by utilizing rolled or welded uprights.

SIMPLE MAINTENANCE

An incredible amount of effort was put into designing the PEGASUS series of trucks with easy access to maintenance needs reducing downtime.

- **Easy access to service engine, transmission and hydraulic system**
- **Preventative maintenance of all major systems can be performed at ground level**
- **Sealed internal hydraulic wet disc brake system**
- **Industry standard components are utilized to ensure rapid part replacement**
- **On board service diagnostic system**
- **Removable cab**
- **Integrated lifting points for safe handling and transport**
- **Floor height fill and lightweight drop down LP tank replacement design**
- **Cut-out for easily visible hydraulic fluid sight glass**
- **Easy access lubrication points**

We included a large electrical compartment to make maintenance simple and accessible. A removable cab design allows for easy access to all major components.

PEGASUS
SP-Series

For more information about PEGASUS SP-Series or to find your local distributor contact RICO 330-723-4050 New Truck Sales.

PEGASUS
ELITE
SERIES

For more information about PEGASUS ELITE or to find your local distributor visit www.hysternorthamerica.com.

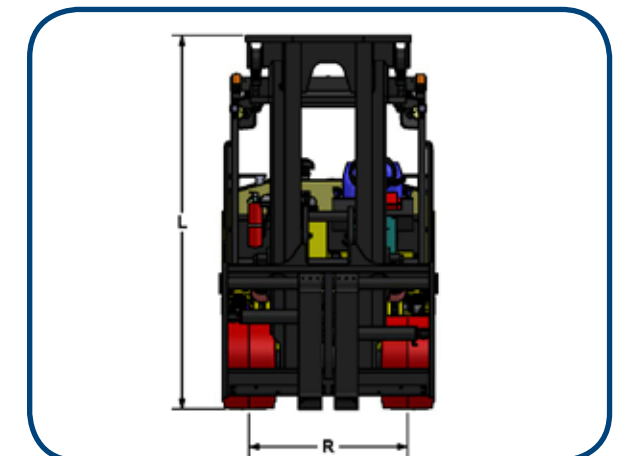
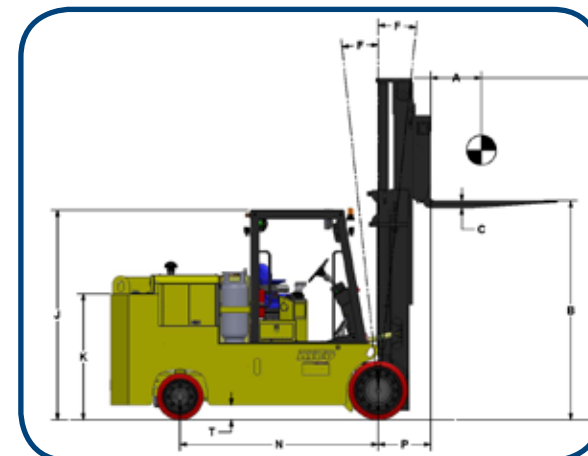

SUPERIOR INNOVATIONS

Standard ELITE Design - AC Electric



HEALTHY POSTURE

- Specifically designed for forklifts, the seat compensates for vibrations.
- Seat back angle, weight, fore and aft adjustment are all just a click away.
- Integrated seat switch ensures safety by only allowing travel of the vehicle while seated.
- Open step operator ingress
- Tilt steer column



CAB FEATURES

- Maximum visibility.
- Removable cab designed to access all major components
- Multi-function display controls
- Dual operator cooling fans
- LED front and rear light package
- Cup holder/tray
- Fire extinguisher



MAST & FORKS

- Wide upright spread allows the operator to see straight through the mast for easy, accurate load spotting.
- Solid forged forks for maximum strength.
- Proportioned taper on forks for coil handling applications.
- Integral side-shifting fork positioner.



STEER WHEELS

- Heavy duty axle steering caster for tighter turning radius, quicker response time and overall ease of operation.



DRIVE AXLE

- Heavy duty planetary drive axle with integral wet disc brakes and force brake cooling.

ACCESSIBILITY

- Maintenance friendly, with hinge doors on both sides of cab and removable floor panel for easy access to inside components.



FLEXIBILITY. VERSATILITY. EFFICIENCY

SUPERIOR INNOVATIONS

Standard ELITE Design - LP Gas, Diesel



TIER 4 FINAL DIESEL

- Diesel powered models are manufactured to Tier 4 Final emissions standards to reduce harmful exhaust gases.



MAST & FORKS

- Wide upright spread allows the operator to see through the mast for easy, accurate load spotting.
- Solid forged forks for maximum strength.
- Proportioned taper on forks for coil handling applications.
- Integral side-shifting fork positioner.



DRIVE AXLE

- Heavy duty planetary drive axle with integral wet disc brakes.



CAB FEATURES

- Removable cab designed to access all major components
- Multi-function display controls
- Dual operator cooling fans
- LED front and rear light package
- Cup holder/tray
- Fire extinguisher



COOLING SYSTEM

- Open finned aluminum radiator with separate fan cooled transmission cooler.



THREE POINT CONTACT

- Large tapered step.
- Strategically placed hand rails to safely descend vehicle.



ACCESSIBILITY

- Easy access hydraulic motor.



EASY ACCESS TANK REPLACEMENT

SUPERIOR INNOVATIONS

Engineering & Design - SP-Series

CAPACITIES UP TO 80,000 LBS. ELECTRICS UP TO 50,000 LBS.



ACCESSIBILITY

- Maintenance-friendly, easy access to all inside components



ROBUST CASTER STEERING

- Mill Duty
- Allows for tighter turning radius
- Suited for performance on rough floor conditions



FULLY ENCLOSED CAB

- Fully enclosed cab can be outfitted with Heaters, Circulating Fans or Air Conditioning for operator comfort.



OPTIONAL CUSTOMIZING TO ELITE STANDARD - NOT LIMITED TO FEATURED OPTIONS SHOWN



FOUNDRY PACKAGE

- Foundry Package for extreme heat working environments for safety and operator comfort
- Foundry Package also safeguards from conditions that could damage truck components and slow down operation



OVERHEAD TILT CYLINDERS

- Optional overhead tilt cylinders can be equipped for extreme lift heights and the most severe applications



SPECIALIZED ATTACHMENTS



SPECIALIZED ATTACHMENTS



SPECIALIZED ATTACHMENTS

FLEXIBILITY. VERSATILITY. EFFICIENCY

SUPERIOR INNOVATIONS

Engineering & Design - Compact SP-Series



COMPACT SIZE FOR SMALLER FOOTPRINT

- Fit through smaller entry ways
- Greater maneuverability for tighter areas
- Reduced height, width and length

OPERATOR CAB FEATURES

- Center-seated vehicle
- 360° operator visibility with open cab and CCTV cameras
- Operator access - low step-in

CAPACITY & FORKS

- Lift capacity 18,000 lbs.
- Integral side-shifting fork positioner

OPTIONAL CUSTOMIZING TO ELITE STANDARD - NOT LIMITED TO FEATURED OPTONS SHOWN

FLEXIBILITY. VERSATILITY. EFFICIENCY





RICO
Life Trucks

RICO Manufacturing, Inc.
691 West Liberty
Medina, OH 44256

Phone 330.723.4050
Fax 330.723.4012

www.RicoEquipment.com

M A T E R I A L H A N D L I N G R E D E F I N E D